

---

**REPORT**

**ON**

***WASTEWATER FACILITY PLAN***

***LONE TREE, IOWA***

***February, 2018***



February 28, 2018

James Oppelt  
Iowa Department of Natural Resources  
502 E. 9<sup>th</sup> Street  
Des Moines, Iowa 50319-0034

LONE TREE, IOWA  
WASTEWATER TREATMENT FACILITY  
FACILITY PLAN SUBMISSION

Enclosed for your review are three copies of the Wastewater Treatment Facility Plan for the City of Lone Tree, Iowa. It outlines improvements to the existing facility needed to stay in conformance with the compliance schedule outlined in the City of Lone Tree's NPDES permit. The Facility Plan is in conformance with the long range planning of the area. The purpose of this submittal is to fulfill the requirements outlined in the City's permit.

The Facility Plan analyzes alternatives to each proposed improvement. The improvement alternatives selected are based on operational and economic feasibility. The recommended improvements in the Facility Plan are both operationally and economically feasible. The recommended improvement alternatives are outlined in Chapter 4 of the enclosed report.

An antidegradation alternatives analysis was submitted in February for the review. All recommendations included in this report are consistent with the findings of the antidegradation analysis. All supplementary reports and information necessary for review of the enclosed Facility Plan are contained in its appendices.

The City is moving forward with the recommendations from the report for improvements including conversion of the existing aerated lagoon treatment facility to activated sludge mechanical treatment with flow equalization and ultraviolet disinfection in order to meet permit limits. The City is planning to bid the improvements in February 2019. Please contact us with questions or comments.

VEENSTRA & KIMM, INC.

A handwritten signature in blue ink that reads "Emily Linebaugh".

Emily Linebaugh  
5192

Enclosures

cc: Stephanie Dautremont, City of Lone Tree



## Exhibit 9B - Preliminary Review of Facility Plan Checklist

“Facility Plan” means a report certified by a professional engineer licensed to practice in Iowa and prepared in conformance with Chapter 11 of the Iowa Wastewater Facilities Design Standards (IWWFDS). A Facility Plan will not be required for non-funded minor sewer extensions, minor trunk and interceptor sewers, and minor pump stations where comprehensive planning is not completed, necessary or required. Facility planning submittals may be returned if they are deemed incomplete by the Department.

**The transmittal letter referenced in Section 11.2.2 of the IWWFDS and a completed Exhibit 9B checklist by the engineer shall be bound with the engineering report.** The transmittal letter must:

- Describe fully the scope of the project identified in Design Schedule A.
- Provide a statement on the feasibility of the project.
- Include a statement that this report has been accepted by the client.
- Indicate that the proposed project is in conformance with the long range planning of the area.
- Reference all information and approved planning reports necessary for a review.
- Clearly indicate the purpose of the submittal.

Exhibit 9B is divided into four sections as follows:

- Section 1 – All Projects
- Section 2 – New or Expanded Wastewater Treatment Facility Projects
- Section 3 – Earthen Basin Projects
- Section 4 – SRF Funded Projects

Section 1 must be completed for all projects. Sections 1 and 2 must be completed for projects involving new or expanded wastewater treatment facilities. Sections 1, 2, and 3 must be completed for projects that consist of new or expanded wastewater treatment lagoon facilities. Sections 1 and 3 must be completed for projects involving new or expanded equalization with earthen basins. In addition, complete Section 4 if the project is SRF funded.

Responses of **“Yes”, “No”, “?”, or Not Applicable (“N/A”)** may be used by DNR in completing Exhibit 9B Preliminary Review with explanations given, as appropriate. A “?” mark may be used by DNR staff where additional follow-up, or the consideration of additional information may be warranted before a comment is offered. Every attempt should be made to complete the Exhibit 9B preliminary review checklist using good engineering judgment and as accurately as possible for the benefit of decision makers. If the response is “No” by the engineer for location maps and/or geotechnical report, the transmittal letter must acknowledge that the Facility Plan is incomplete and provide adequate need and justification for the Department to initiate a concept review.

**Section 1 – All Projects**

1. A work initiation meeting determination has been made. If the meeting was determined to be necessary, the meeting has been held. The scope and milestones for the project have been clearly established.
2. A project location and a recommended alternative have been proposed by the A/E and the conclusion accepted by the Owner in accordance with Step 17, Section 11.2 of the Iowa Wastewater Facilities Design Standards and Design Schedule A.
3. A completed and signed Design Schedule A has been submitted in accordance with Section 11.1 of the Iowa Wastewater Facilities Design Standards.
4. Any proposed variation from the design standards contained in Chapter 567 IAC 64 is identified by the Engineer in accordance with Design Schedule A with justification provided in accordance with DNR rules.
5. A complete and achievable project implementation schedule has been provided identifying all project milestones in accordance with Section 11.2.5.3(k) of the Design Standards.
6. The Appendix (Technical Information and Design Criteria) is provided per Design Standard 11.2.11.
7. The facility plan is signed and certified by a professional engineer licensed in the State of Iowa.

Section 1 – Comment Box:

**Section 2 – New or Expanded Wastewater Treatment Plant Projects**

- 8. The Owner has filed an application for a new or amended NPDES permit as needed for the improvements described in the Facility Plan and has notified the review engineer of this submission.
- 9. Completed Design Schedules F and G have been submitted in accordance with Section 11.1 of the Iowa Wastewater Facilities Design Standards.
- 10. The location maps are prepared by the Engineer in accordance with Design Schedule F to the recommended scale and provide all requested detail to conduct a site survey investigation for the proposed new or expanded wastewater treatment facilities.
- 11. All hydraulic and organic design loadings in Design Schedule G and the Facility Plan are consistent with the preliminary design loadings concurred by the Department.
- 12. The project has conformed to the Waste Load Allocation (WLA) determination and the effluent limits which have been established by the DNR through Steps 9, 11, 12, 13, and 14 of the wastewater construction permitting procedures.
- 13. Where anti-degradation requirements apply, the recommended alternative is consistent with the anti-degradation alternatives analysis approved by the Department.
- 14. New Process Evaluation - all required engineering data and design basis formulated from the data for New Process Evaluation has been approved by the Department under Section 14.4.3 and was prepared by a licensed professional engineer other than the one employed by the manufacturer or patent holder.

Section 2 – Comment Box:

**Section 3 – Projects with Earthen Basins (Lagoon and Equalization Basins)**

- 15. A completed geotechnical investigation engineering report is provided as a supplement to the engineer’s report.

Section 3 – Comment Box:

**Section 4 – State Revolving Fund (SRF) Loan Projects**

- 16. The proposed project is a fundable category (Refer to Subrule 567 IAC 90.2) for receipt of a CWSRF loan.
- 17. The Intended Use Plan application (Exhibit 8) is enclosed with the Facility Plan and the “Assurance with Respect to Real Property Acquisition” form.
- 18. The Property/Easement Acquisition Schedule is included.
- 19. The Owner has submitted all required Exhibit 5 information to the Environmental Review Services Coordinator in order to initiate the SRF environmental review.

Section 4 – Comment Box:

*This page for DNR Use Only*

**DNR Decisions:**

9B Complete

Concept Review Request

**Conclusions by DNR:**

A large, empty rectangular box with a thin black border, intended for DNR conclusions. It occupies the majority of the page's vertical space below the 'Conclusions by DNR:' header.

**REPORT  
ON  
WASTEWATER FACILITY PLAN  
LONE TREE, IOWA  
February, 2018**

I hereby certify that this engineering document was prepared by me or under my direct personal supervision and that I am a duly licensed Professional Engineer under the laws of the State of Iowa.

Signed:

Date:

*Emily Linebaugh*

*2/28/18*

Emily Linebaugh, P.E.

Iowa License No. 18986

My license renewal date is December 31, 2019



Parts covered by this seal:

*ALL*

Prepared by  
VEENSTRA & KIMM, INC.  
Coralville,  
Iowa



**WASTEWATER FACILITY PLAN  
LONE TREE, IOWA**

**CONTENTS**

	<b>Page</b>
<b>CHAPTER 1 - GENERAL</b> .....	1-1
INTRODUCTION .....	1-1
SCOPE .....	1-1
DESCRIPTION OF SERVICE AREA.....	1-1
PRESENT LAND USE.....	1-1
PLANNING PERIOD .....	1-1
ENVIRONMENTAL CONDITIONS.....	1-2
GEOLOGY .....	1-2
TOPOGRAPHY AND DRAINAGE.....	1-2
SOILS.....	1-2
COST ESTIMATES AND PRESENT WORTH ANALYSES.....	1-2
<b>CHAPTER 2 - POPULATION AND FLOWS</b> .....	2-1
POPULATION .....	2-1
STUDENTS .....	2-1
WASTEWATER FLOWS.....	2-1
LOADINGS.....	2-5
FUTURE WASTEWATER HYDRAULIC AND ORGANIC LOADINGS .....	2-8
<b>CHAPTER 3 – EVALUATION OF EXISTING FACILITY</b> .....	3-1
EXISTING SITE CONDITIONS.....	3-1
FACILITY OVERVIEW .....	3-1
LAGOON VOLUMES.....	3-2
PLANT HYDRAULICS .....	3-3
LAGOON CELL DEPTH .....	3-3
AEARTION REQUIREMENTS .....	3-3
CURRENT SAMPLING PROCEDURES.....	3-4
HIGH FLOW OPERATIONS.....	3-4
STREAM CLASSIFICATION .....	3-4
EXISTING EFFLUENT LIMITATIONS .....	3-5
<b>CHAPTER 4 - TREATMENT ALTERNATIVES</b> .....	4-1
ALTERNATIVE 1 – EXISTING AERATED LAGOON TREATMENT FACILITY.....	4-1
ALTERNATIVE 2 – LAND APPLICATION .....	4-1
ALTERNATIVE 3 – MECHANICAL TREATMENT.....	4-1
Alternative 3A – Sequencing Batch Reactor.....	4-4
Alternative 3B – SEQUOX .....	4-5

	<b>Page</b>
ALTERNATIVE 4 – ENHANCED TREATMENT AERATED LAGOON PROCESS .....	4-6
Alternative 4A – OPTAER Wastewater Treatment System .....	4-7
Alternative 4B – LEMTEC Biological Treatment Process.....	4-8
Alternative 4C – IDEAL Bioreactor .....	4-10
SUMMARY OF AMMONIA ALTERNATIVES .....	4-11
DISCUSSION OF AMMONIA ALTERNATIVES .....	4-12
SELECTED ALTERNATIVE .....	4-13
<b>CHAPTER 5 - ENVIRONMENTAL IMPACT .....</b>	<b>5-1</b>
GENERAL.....	5-1
NATURAL ENVIRONMENT .....	5-1
Water Quality .....	5-1
Air Quality.....	5-1
Noise.....	5-2
Energy .....	5-2
SOCIO-ECONOMICAL FACTORS.....	5-2
Population .....	5-2
Economy .....	5-2
Land Use .....	5-3
SENSITIVE AREAS .....	5-3
Wildlife Habitats.....	5-3
Rare and Endangered Species.....	5-3
Cultural Resources .....	5-4
Recreational and Open Space .....	5-4
IRRETRIEVABLE AND IRREVERSIBLE COMMITMENT OF RESOURCES.....	5-4
<b>CHAPTER 6 - FINANCING .....</b>	<b>6-1</b>
GENERAL.....	6-1
METHODS OF FINANCING .....	6-1
General Obligation Bonds .....	6-1
Revenue Bonds.....	6-1
Special Assessment Bonds.....	6-2
General Obligation Bonds/Abated with Utility Revenues .....	6-2
State Revolving Fund (SRF).....	6-2
<b>CHAPTER 7 - SCHEDULE.....</b>	<b>7-1</b>
<b>CHAPTER 8 - SUMMARY AND RECOMMENDATIONS.....</b>	<b>8-1</b>

<b>TABLES</b>	<b>Page</b>
Table 2-1: Population .....	2-1
Table 2-2: Wastewater Flows .....	2-3
Table 2-3: BOD <sub>5</sub> Loadings .....	2-6
Table 2-4: TSS Loadings .....	2-7
Table 2-5: NPDES Permit Design Capacities .....	2-8
Table 2-6: Wastewater Treatment Facility Design Criteria .....	2-8
Table 3-1: Wastewater Treatment Facility Permitted Hydraulic Capacity .....	3-1
Table 3-2: End of Pipe Limits for Mechanical Facilities .....	3-7
Table 4-1: Sequencing Batch Reactor Mechanical Plant Cost Estimate.....	4-5
Table 4-2: Aero-Mod Mechanical Plant Cost Estimate .....	4-6
Table 4-3: OPTAER Wastewater Treatment System Cost Estimate.....	4-8
Table 4-4: LemTec Wastewater Treatment System Cost Estimate .....	4-10
Table 4-5: IDEAL Bioreactor Wastewater Treatment System Cost Estimate.....	4-11
Table 4-6: Summary of Estimated Project Costs for Each Treatment Alternative .....	4-11
Table 7-1: Proposed Project Schedule .....	7-1

<b>FIGURES</b>	<b>Follows Page</b>
Figure 3-1: Site Separation .....	3-1
Figure 3-2: Existing Facility .....	3-2
Figure 3-3: Effluent Ammonia Lone Tree, Iowa .....	3-6
Figure 4-1: SBR Site Plan .....	4-4
Figure 4-2: Aero-Mod Site Plan .....	4-6
Figure 4-3: OPTAER/SAGR Site Plan .....	4-8
Figure 4-4: LemTec Site Plan .....	4-10
Figure 4-5: IDEAL Site Plan.....	4-11

## **APPENDICES**

**APPENDIX A** - NPDES PERMIT

**APPENDIX B** - UV DISINFECTION PROPOSALS  
GLASCO, INC.  
TROJAN UV

**APPENDIX C** - PRELIMINARY TREATMENT PROPOSALS  
STAIR SCREEN (VULCAN)  
SPIRAL SCREEN (PARKSON)  
GRIT REMOVAL (HYDRO INTERNATIONAL)

**APPENDIX D** - MECHANICAL TREATMENT PROPOSALS  
SEQUENCING BATCH REACTOR (FLUIDYNE CORP.)  
SEQUOX (AER-MOD, INC.)

**APPENDIX E** - ENHANCED AERATED LAGOON PROPOSALS  
OPTAER/SAGR (NEXOM, INC.)  
LEMTEC (LEMNA TECHNOLOGIES, INC.)  
IDEAL (ENVIRONMENTAL DYNAMICS INTERNATIONAL, INC.)

# **CHAPTER 1 - GENERAL**

## **INTRODUCTION**

This report presents the results of the Wastewater Facility Plan completed for the City of Lone Tree. The Facility Plan was undertaken to address the continued growth of the City of Lone Tree, operational difficulties at the facility, periodic sanitary sewer overflows, periodic bypassing of sanitary flows and the impact of changes to the discharge limitations due to new water quality standards in the State of Iowa.

## **SCOPE**

This report presents the results of the engineering study and analysis of the wastewater treatment facilities for the City of Lone Tree, Iowa. The Wastewater Facility Plan includes the following:

1. Review of the past 5 years of operational records and the performance of the existing wastewater treatment facility (WWTF).
2. Review of the physical condition of the existing WWTF.
3. Evaluation of existing and future hydraulic and biological loading of the facility.
4. Identification of alternatives for upgrading or replacing the existing WWTF to meet current and future needs and forthcoming regulatory requirements.
5. Preliminary design considerations, estimated cost and methods of financing the recommended improvements.

## **DESCRIPTION OF SERVICE AREA**

The service area includes the incorporated limits of the City of Lone Tree. The City of Lone Tree is located in eastern Iowa approximately 13 miles southeast of Iowa City.

## **PRESENT LAND USE**

The community consists of residential development with some commercial development.

## **PLANNING PERIOD**

The Iowa Department of Natural Resources requires the planning period for proposed improvements extend at least 20 years beyond the date when the improvements are scheduled to begin operation. For the purposes of this report, the planning period will be 20 years and extend to the year 2038.

## **ENVIRONMENTAL CONDITIONS**

The climate in the area of study is characterized by seasonal contrasts and highly variable weather typical of this humid continental region. The monthly mean temperatures range from 13 °F to 88 °F throughout the year. The extreme temperatures range from -24 °F to 104 °F. Average rainfall is 37.3 inches per year with an average range of 1.1 to 4.9 inches per month throughout the year. Summer winds are commonly from the southern quadrant, dominated by tropical masses from the Gulf of Mexico. Polar air masses from the north are typical during the winter months.

## **GEOLOGY**

The geology of the study area is comprised of Devonian aged bedrock deposited during the rise and fall of sea level approximately 300 million years ago.

## **TOPOGRAPHY AND DRAINAGE**

The general ground surface topography consists of level to general sloping terrain. The drainage in the study area flows into Prairie Creek and its tributaries as well as Hackey's Slough. Ultimately Prairie Creek flows into the Iowa River. Hackey's Slough flows into Wapsinonoc Creek which flows into the Cedar River.

## **SOILS**

Generally, the soil types in the study area can be characterized as well-drained loamy or silty materials.

## **COST ESTIMATES AND PRESENT WORTH ANALYSES**

The facility planning includes preliminary estimates of cost for proposed improvements. The cost estimates include the estimated construction cost as well as a 15% contingency allowance and a 15% allowance for engineering, legal and administrative.

The preliminary estimates of cost are an "order of magnitude cost estimate" based on a facility planning level of analysis. The facility planning cost estimates are approximate. Generally, facility planning cost estimates are considered accurate to within a range of plus or minus 15%.

All costs included herein represent present day costs. No provisions have been made for inflation or deflation.

## CHAPTER 2 - POPULATION AND FLOWS

### POPULATION

The City of Lone Tree continues to experience a growing population trend. The U.S. Census Data from 1990 through 2010 was used to project a linear growth rate of 90 people every 5 years. The design population for a 20-year facility plan is estimated to be 1,800 people in the year 2038. The historical population as well as projected population for Lone Tree is shown in Table 2-1 below.

**Table 2-1: Population**

Year	Population
1990	979
2000	1,151
2010	1,300
2015	1,390 (est.)
2020	1,480 (est.)
2025	1,570 (est.)
2030	1,660 (est.)
2035	1,750 (est.)
2038	1,800 (est.)

### STUDENTS

The Lone Tree Community School District serves the City of Lone Tree and rural students in the surrounding area. All of the schools in the Lone Tree Community School District are located in Lone Tree, Iowa. For the 2012-2013 school year, the number of students attending school in the Lone Tree Community School District was approximately 425. The student population does not include a significant number of out-of-town students. As a result, it is anticipated that the out-of-town student population will not have a significant impact on wastewater flows at the facility.

### WASTEWATER FLOWS

Existing wastewater flows and loadings were determined by analyzing the Monthly Operating Reports (MORs) from January 2010 to December 2016. Table 2-2 presents a summary of the average monthly wastewater flows and daily peak flows for the period. Wastewater flows shown in Table 2-2 were measured at the influent flume. The ultrasonic level sensor at the influent flume was out of service for the months of May 2010 through June 2010. Consequently, there are no flows shown for those months in Table 2-2. At flows above 1.7 MGD, the influent flume becomes flooded and flow readings become less accurate.

The Iowa Department of Natural Resources (IDNR) requires wastewater flows during specific conditions be determined to establish the design parameters for improvements to wastewater treatment facilities. These conditions include the following:

Average Dry Weather (ADW) Flow - The daily average flow when the groundwater is at or near normal and runoff is not occurring.

Average Wet Weather (AWW 180) Flow - The daily average flow for the wettest 180 consecutive days.

Average Wet Weather Flow (AWW 30) - The daily average flow for the wettest 30 consecutive days.

Maximum Wet Weather (MWW) Flow - The total maximum flow received during any 24-hour period when the groundwater is high and runoff is occurring.

Peak Hourly Wet Weather (PHWW) Flow - The total maximum flow received during one hour when the groundwater is high, runoff is occurring, and the domestic, commercial and industrial flows are at their peak.



**Table 2-2: Wastewater Flows**

Year	Month	30-Day Average gpd	Maximum gpd	Year	Month	30-Day Average gpd	Maximum gpd
2011	January	196,452	365,000	2014	January	104,226	134,000
	February	339,000	1,031,000		February	137,786	680,000
	March	423,613	974,000		March	169,097	447,000
	April	392,300	758,000		April	199,233	405,000
	May	316,323	549,000		May	185,742	299,000
	June	446,767	1,278,000		June	232,900	1,220,000
	July	180,871	315,000		July	282,290	985,000
	August	114,484	144,000		August	191,645	1,090,000
	September	299,567	171,000		September	411,600	1,767,000
	October	104,645	138,000		October	341,258	1,378,000
	November	152,133	352,000		November	216,467	452,000
	December	190,742	482,000		December	217,742	362,000
		<b>Average</b>	<b>263,075</b>			<b>Average</b>	<b>224,165</b>
	<b>Maximum</b>	<b>446,767</b>	<b>1,278,000</b>	<b>Maximum</b>	<b>411,600</b>	<b>1,767,000</b>	
2012	January	155,161	188,000	2015	January	202,258	257,000
	February	182,857	281,000		February	216,893	330,000
	March	207,387	317,000		March	261,323	460,000
	April	213,100	587,000		April	303,567	879,000
	May	193,355	333,000		May	407,355	1,566,000
	June	123,867	199,000		June	308,033	704,000
	July*	97,871	141,000		July	373,548	1,260,000
	August*	98,032	423,000		August	166,258	403,000
	September*	112,000	247,000		September	188,000	584,000
	October	120,903	257,000		October	168,677	374,000
	November	128,667	243,000		November	417,067	867,000
	December	133,194	306,000		December	532,581	915,000
		<b>Average</b>	<b>147,199</b>			<b>Average</b>	<b>295,463</b>
	<b>Maximum</b>	<b>213,100</b>	<b>587,000</b>	<b>Maximum</b>	<b>532,581</b>	<b>1,566,000</b>	
2013	January	161,710	362,000	2016	January	337,806	617,000
	February	232,000	548,000		February	246,000	448,000
	March	332,516	1,510,000		March	242,935	484,000
	April	518,300	2,060,000		April	195,667	266,000
	May	467,000	1,800,000		May	231,000	1,400,000
	June	263,433	680,000		June	231,000	1,400,000
	July	152,645	280,000		July	358,097	866,000
	August*	94,032	111,000		August	426,161	1,860,000
	September*	85,533	112,000		September	299,700	840,000
	October*	98,290	196,000		October	166,677	288,000
	November	121,033	167,000		November	184,400	358,000
	December	105,355	125,000		December	175,935	328,000
		<b>Average</b>	<b>219,321</b>			<b>Average</b>	<b>257,948</b>
	<b>Maximum</b>	<b>518,300</b>	<b>2,060,000</b>	<b>Maximum</b>	<b>426,161</b>	<b>1,860,000</b>	

\*Drought conditions during these months

To determine the ADW flow based on historical data, typically the three lowest monthly flows during the analysis period are averaged. Usually the lowest wastewater flow periods are from December to February. For Lone Tree, the lowest flow periods do not appear to coincide with the traditionally low flow winter months as might be anticipated. The lowest flows in Lone Tree have often occurred during the late summer/early fall months. For this reason, the data examining only winter months (December, January, February) may give artificially high estimates of the ADW flow. In the situation where the winter period does not yield the lowest flows, the 30<sup>th</sup> percentile flow is used to determine the ADW. Using the 30<sup>th</sup> percentile flow, the ADW flow is estimated to be 0.135 MGD or 97 gpcpd.

The AWW 30 flow is the daily average flow for the wettest 30 consecutive days. This flow is generally used for sizing mechanical treatment facilities and is one of two critical flow numbers used to size aerated lagoons. A review of MOR data shows the maximum AWW 30 flow occurred between July 24 and August 22, 2010. The AWW 30 flow rate is 740,000 gpd or 0.740 MGD.

The AWW 180 flow is the daily average flow for the wettest 180 consecutive days. A review of Table 2-2 shows the maximum AWW 180 flow occurred during the months of July 2010 through December 2010. The AWW 180 flow rate is 361,000 gpd or 0.361 MGD.

The MWW flow is the maximum flow for a 24-hour period. The maximum recorded flow occurred on April 18, 2013. The MWW flow was 2.060 MGD.

The PHWW flow is estimated based on conversations with City staff and calculations of sewer capacity. During peak flow periods the sanitary sewer is known to be surcharged, the northwest lift station is operating at capacity and a portion of the flow received at the WWTF is bypassed to a holding lagoon (which is not metered).

As there is no written record available, the alternative method used estimates the peak flow that could physically reach the facility. The northwest lift station is capable of producing 1.0 MGD with both pumps operating; the 12" influent sewer when surcharged has a capacity of 1.7 MGD; and the 15" influent sewer has a capacity of 3.0 MGD. Adding these three influent sources provides a potential PHWW flow of 5.7 MGD. The influent flow meter structure may allow up to 3.1 MGD to flow through (approximately 2.0 MGD can be metered accurately). During periods of high flow, up to 2.6 MGD is sent to the holding lagoon. The potential PHWW to ADW flow represents a peaking factor of 42. This peaking factor is higher than would be expected for a community of Lone Tree's size and indicates a problem with infiltration and inflow. Better data on PHWW flow is required to confirm this peaking factor.

## LOADINGS

Wastewater influent is sampled once each week for 5-day biochemical oxygen demand (BOD<sub>5</sub>) and once each month for total suspended solids (TSS). Starting in May 2015, the WWTP began sampling TSS twice per month and switched from influent BOD<sub>5</sub> testing to influent CBOD<sub>5</sub> testing. There was no noticeable difference between the BOD<sub>5</sub> and CBOD<sub>5</sub> test results. Therefore, for this report the BOD<sub>5</sub> and CBOD<sub>5</sub> data were assumed to be equivalent. Both BOD<sub>5</sub> and CBOD<sub>5</sub> test results are referred to as BOD<sub>5</sub> in this report. Tables 2-3 and 2-4 present a summary of the BOD<sub>5</sub> and TSS loadings for the six years of MORs analyzed. A conventional technique for estimating influent BOD<sub>5</sub> is to use the maximum 30-day average over the past 5 years as a representative number for the current loading rate. For Lone Tree, the three largest monthly loadings (February 2011: 344 ppd, July 2013: 419 ppd, September 2014: 462 ppd) were significantly higher than the five-year average (198 ppd). These increased loading, likely the result of infrequent sampling and fluctuating waste flows due to I&I, were not considered representative and were therefore disregarded. After removing these data points, a BOD<sub>5</sub> load of 290 ppd was determined reasonable for Lone Tree. On a per capita basis, this BOD<sub>5</sub> loading equates to 0.20 lbs/capita/day (ppcd). The IDNR design standard for BOD<sub>5</sub> is 0.17 ppcd and 0.22 ppcd when garbage disposals are used in areas tributary to the WWTF.

As is the case with BOD<sub>5</sub>, the conventional technique for estimating influent TSS is to use the maximum 30-day average over the past 5 years as a representative number for the current loading rate. For Lone Tree, there were several months where the calculated influent TSS was over 500 ppd. These increased loading rates, likely the result of infrequent sampling and fluctuating waste flows due to I&I, were not considered representative. Any monthly TSS value over 500 ppd was disregarded. After removing these data points, a TSS load of 390 ppd was determined reasonable for Lone Tree. On a per capita basis, this TSS loading equates to 0.28 ppcd. The IDNR design standard for BOD<sub>5</sub> is 0.20 ppcd and 0.25 ppcd when garbage disposals are used in areas tributary to the WWTF.

No data was available for Total Kjeldahl Nitrogen (TKN) as the City is not required to perform sampling of TKN. The per capita loading recommended by IDNR is 0.036 lbs/capita/day. The TKN loading was determined by using a TSS population equivalent. The calculated TKN loading for Lone Tree is 63 ppd.

**Table 2-3: BOD<sub>5</sub> Loadings**

Year	Month	Average ppd	Maximum ppd	Year	Month	Average ppd	Maximum ppd
2011	January	240	325	2014	January	158	259
	February	344	671		February	284	624
	March	193	333		March	165	197
	April	198	241		April	165	232
	May	216	333		May	119	131
	June	281	465		June	149	210
	July	200	284		July	134	200
	August	184	215		August	132	183
	September	228	290		September	462	1,002
	October	179	215		October	192	244
	November	276	544		November	216	298
	December	195	297		December	214	332
	<b>Average</b>	<b>228</b>			<b>Average</b>	<b>199</b>	
	<b>Maximum</b>	<b>344</b>	<b>671</b>		<b>Maximum</b>	<b>462</b>	<b>1,002</b>
2012	January	237	299	2015	January	140	167
	February	220	324		February	145	169
	March	165	202		March	183	304
	April	173	197		April	173	312
	May	175	262		May	116	156
	June	147	162		June	119	133
	July	132	169		July	181	385
	August	204	384		August	123	144
	September	213	340		September	117	155
	October	320	498		October	234	532
	November	245	503		November	223	300
	December	108	126		December	89	138
	<b>Average</b>	<b>195</b>			<b>Average</b>	<b>153</b>	
	<b>Maximum</b>	<b>320</b>	<b>503</b>		<b>Maximum</b>	<b>234</b>	<b>532</b>
2013	January	120	170	2016	January	140	193
	February	300	615		February	177	242
	March	282	628		March	119	171
	April	188	274		April	113	127
	May	144	162		May	102	127
	June	110	187		June	152	259
	July	419	976		July	119	163
	August	209	394		August	162	194
	September	203	431		September	168	354
	October	176	281		October	129	159
	November	184	229		November	123	204
	December	211	292		December	139	354
	<b>Average</b>	<b>212</b>			<b>Average</b>	<b>137</b>	
	<b>Maximum</b>	<b>419</b>	<b>976</b>		<b>Maximum</b>	<b>177</b>	<b>354</b>

**Table 2-4: TSS Loadings**

Year	Month	Average ppd	Year	Month	Average ppd	Maximum ppd
2011	January	208	2014	January	129	
	February	348		February	108	
	March	505		March	250	
	April	228		April	56	
	May	302		May	162	
	June	345		June	240	
	July	292		July	99	
	August	188		August	57	
	September	234		September	2,004	
	October	312		October	777	
	November	266		November	651	
	December	249		December	235	
	<b>Average</b>	<b>290</b>		<b>Average</b>	<b>397</b>	
<b>Maximum</b>	<b>505</b>	<b>Maximum</b>	<b>2,004</b>			
2012	January	662	2015	January	348	
	February	227		February	136	
	March	283		March	285	
	April	282		April	274	
	May	386		May	132	141
	June	221		June	140	179
	July	120		July	239	314
	August	110		August	170	216
	September	152		September	141	175
	October	152		October	266	387
	November	126		November	1,402	1,629
	December	52		December	301	474
	<b>Average</b>	<b>231</b>		<b>Average</b>	<b>319</b>	
<b>Maximum</b>	<b>662</b>	<b>Maximum</b>	<b>1,402</b>	<b>1,629</b>		
2013	January	132	2016	January	113	150
	February	108		February	339	508
	March	126		March	154	185
	April	237		April	155	164
	May	196		May	178	216
	June	173		June	353	722
	July	1,717		July	129	158
	August	508		August	397	463
	September	82		September	233	300
	October	125		October	150	161
	November	135		November	136	144
	December	195		December	181	144
	<b>Average</b>	<b>311</b>		<b>Average</b>	<b>210</b>	
<b>Maximum</b>	<b>1,717</b>	<b>Maximum</b>	<b>397</b>	<b>722</b>		

## FUTURE WASTEWATER HYDRAULIC AND ORGANIC LOADINGS

The future wastewater hydraulic and organic loadings for the design year 2038 are determined based on the future population projection and the average per capita contribution for the flows and loadings. The existing NPDES Permit for the City of Lone Tree contains a design capacity as show in Table 2-5.

**Table 2-5: NPDES Permit Design Capacities**

	<b>NPDES Permit 2015</b>
<b>Flow, MGD</b>	
ADW	0.1150
AWW	0.4170
MWW	1.6000
<b>Organic Loadings lbs./day</b>	
BOD <sub>5</sub>	228
TKN	n/a

The existing treatment process is a two-cell aerated lagoon with a quiescent cell. Improvements to the existing treatment process must be made to meet new effluent limitations proposed by the IDNR – specifically, nitrogen removal and *E.coli* disinfection. To achieve these proposed effluent limitations, new treatment methods will be required. Table 2-6 presents the proposed design criteria for the Lone Tree WWTF in the design year 2038 with an estimated population of 1,800. Future flows and organic loadings are based on projected population growth and IDNR design standards.

**Table 2-6: Wastewater Treatment Facility Design Criteria**

	<b>2015</b>	<b>2038</b>
<b>Population</b>	<b>1,390</b>	<b>1,800</b>
<b>Flow, MGD</b>		
ADW	0.1350	0.1760
AWW 180	0.3610	0.4020
AWW 30	0.7400	0.8220
MWW	2.0600	2.2240
PHWW	5.7000	5.7000
<b>Organic Loadings lbs./day</b>		
BOD <sub>5</sub>	290	360
TSS	390	472
TKN	63	78

## CHAPTER 3 – EVALUATION OF EXISTING FACILITY

### EXISTING SITE CONDITIONS

The existing WWTF is located on approximately 13 acres of land southwest of the City of Lone Tree. A typical challenge for expanding existing wastewater treatment facilities is the location of the site in relationship to existing homes, physical features such as rivers, creeks, drainage ditches, roads, railroads, and property lines.

The Iowa Department of Natural Resources has established site separation requirements that must be checked when expanding the facility. The required separation distances are 1,000 feet from the nearest inhabitable residence, commercial building, inhabitable structure or public shallow wells; 400 feet from public deep wells, private wells and lakes and public impoundments; and 25 feet from property lines.

Under Iowa Department of Natural Resources rules, when expanding the facility, the expansion must maintain 90% of the existing separation distance of the site. To obtain a variance to the separation rule, the City must obtain a written agreement with the property owner and have the agreement filed with the County Recorder. It appears a variance will not be necessary to expand the treatment facility at this site. Figure 3-1 shows site separation distances.



### FACILITY OVERVIEW

The City of Lone Tree's WWTF was converted to a three-cell aerated lagoon system in 1999. Prior to the 1999 improvements, the WWTF was a three-cell controlled discharge lagoon system. To convert the controlled discharge lagoon to an aerated lagoon, Cell No. 1 was fitted with a diffused aeration system and divided into two cells using a floating baffle. Cell No. 2 was shown to be abandoned during the 1999 upgrade but is still available as equalization. Cell No. 3 remained in service as the quiescent cell of the system. The permitted hydraulic capacity of the existing plant is shown in Table 3-1.

**Table 3-1: Wastewater Treatment Facility Permitted Hydraulic Capacity**

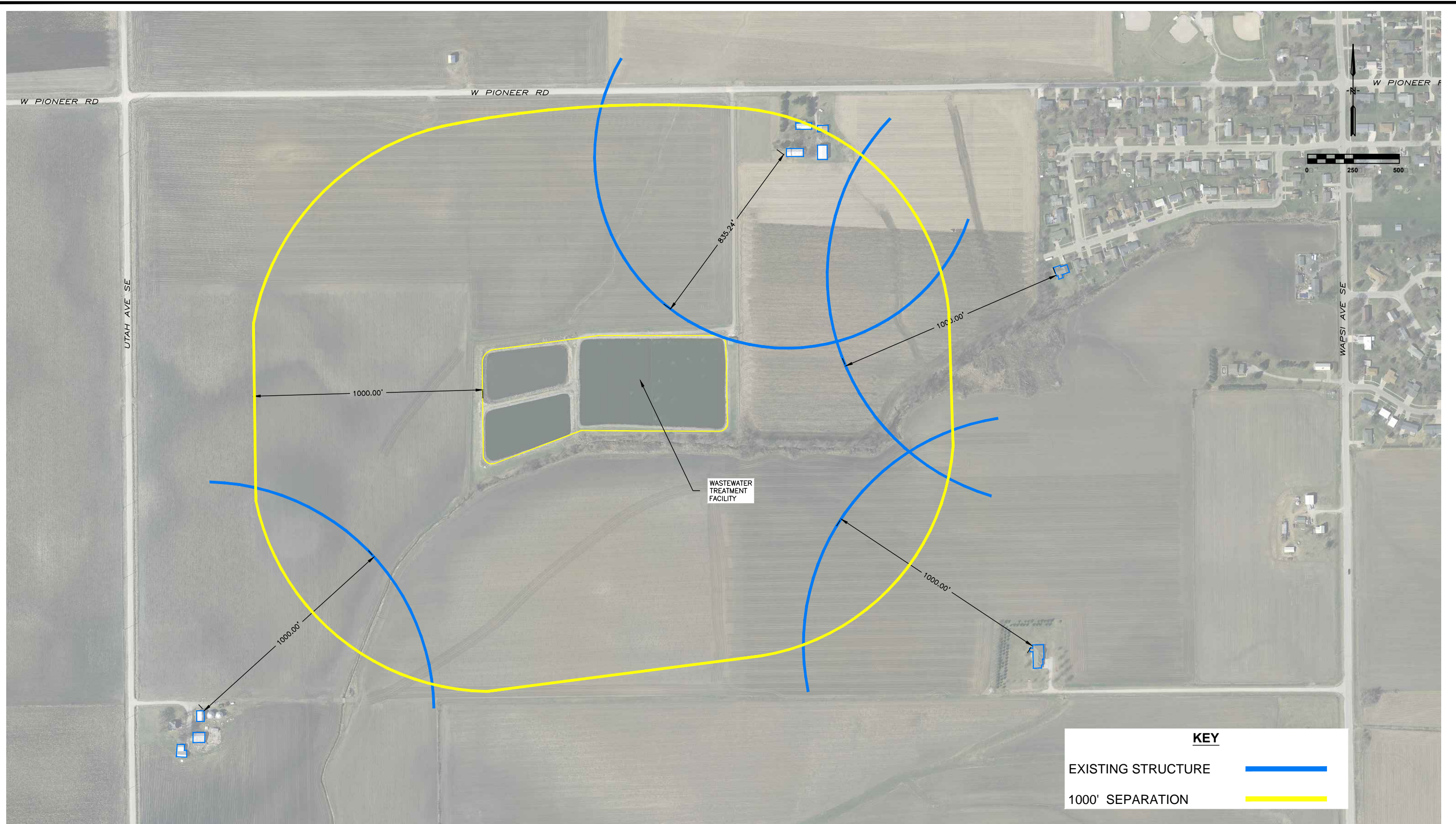
	<u>1999 Improvements</u>
ADW, mgd	0.1150
AWW, mgd	0.4170
MWW, mgd	1.6000



KEY	
EXISTING STRUCTURE	
1000' SEPARATION	



VEENSTRA & KIMM, INC.

SITE SEPARATION  
LONE TREE, IOWA  
FIGURE 3-1



The layout of the existing WWTF is shown in Figure 3-2. Wastewater enters the facility through three pipes: an 8-inch force main, a 12-inch gravity flow sewer and a 15-inch gravity flow sewer. All three pipes discharge to one manhole. Downstream of that manhole, influent wastewater is sent to the Flow Measurement Structure where it is metered using a 6-inch Parshall flume. From there, water flows to the Inlet Structure where it drops into a 12-inch pipe that conveys the wastewater to Cell No. 1 (4.9 MG). Wastewater then flows through the floating curtain baffle to aerated lagoon Cell No. 2 (4.7 MG). From there, wastewater enters lagoon Cell No. 3 (3.6 MG), the Quiescent Cell. Finally, water flows from the Quiescent Cell through the outlet structure and over a v-notch weir where it is discharged to Prairie Creek. While some pipe sizes and locations are noted on Figure 3-2, it should be noted that there are inconsistencies between plan documents and what is observed in the field. The piping shown on Figure 3-2 is drawn based upon best available information.

### **LAGOON VOLUMES**

The IDNR Design Standards have specific requirements regarding the storage volume of aerated lagoon facilities. Chapter 18C, Paragraph 4.4.2 of the IDNR Design Standards states the design flow for sizing lagoons that treat municipal waste shall be “based upon the ADW flow plus 30% of the 30-day average wet weather (AWW-30) flow in excess of the ADW flow, or 100 gpcd, whichever is greater.” Chapter 18C, paragraph 6.1.1 of the IDNR Design Standards states the minimum hydraulic retention time for a facultative pond system (aerated lagoon system) designed to treat typical domestic sewage is 31 days. Specifically, for a facultative system with 2 aerated cells, the minimum hydraulic retention time is 29 days for the aerated cells and 2 days for the quiescent cell.

Using these design criteria, we evaluated the existing lagoons ability to provide adequate storage time at the currently permitted flows. Using flows from Table 3-1, the currently permitted design flow ( $ADW + (0.3)(AWW-ADW)$ ) was determined to be 0.205 MGD. At this flow, the hydraulic retention times of the aerated and quiescent cells are 47 days and 22 days, respectively. Therefore, the lagoon cells are adequately sized to handle currently permitted flows.

We then evaluated the existing lagoon cells’ storage time at the projected future design flows. Using flows from Table 2-6, the projected future design flow was determined to be 0.370 MGD. At this flow, the hydraulic retention times of the aerated and quiescent cells are 24 days and 12 days, respectively. Based on these calculations, the current configuration of the aerated lagoon cells would not meet IDNR design standards for hydraulic capacity. The current quiescent cell does meet IDNR design standards for hydraulic capacity at future design flows.



KEY	
TRUNK SEWER	
FORCE MAIN	
AIR LATERALS	
BAFFLE CURTAIN	
EFFLUENT SEWER	
WATER MAIN	



VEENSTRA & KIMM, INC.

EXISTING FACILITY  
LONE TREE, IOWA  
FIGURE 3-2

## **PLANT HYDRAULICS**

Chapter 18C, paragraph 7.6.2.b of the IDNR Design Standards states that pond piping for a continuous discharge lagoon facility “shall allow for a minimum of 250% of the design flow of the system or MWW flow, whichever is greater.” In the case of Lone Tree, 250% of the design flow (0.9245 MGD) is less than the MWW flow (2.224 MGD). Therefore, the MWW flow was used to determine compliance with the state standard. A hydraulic analysis of plant piping showed no hydraulic restriction in the existing piping at 2.224 MGD. However, the operator has reported when flows reach approximately 2.0 MGD, he opens a gate and allows excess wastewater to flow to the northwest basin which acts as a storm basin for excess flow.

## **LAGOON CELL DEPTH**

Chapter 18C, paragraph 6.3 of the IDNR Design Standards states that “the depth of cells should be in the range of 10-15 feet and shall be at least five feet.” Lone Tree’s aerated lagoon cells have a design water depth of 6 feet. The quiescent and storm cell have a design water depth of 8 feet. While not an ideal depth, the cells do meet the design minimum standards.

## **AERATION REQUIREMENTS**

Chapter 18C, paragraph 6.4.1 of the IDNR Design Standards states that “aeration equipment shall be capable of supplying a minimum of 2 lbs. O<sub>2</sub>/lb BOD applied, and maintain an average dissolved oxygen level of 2 mg/L or greater in the cells at all times.” In order to supply 2 lbs. O<sub>2</sub>/lb BOD at the design BOD load of 360 ppd with a water depth of only 5 feet, the blowers would need to deliver 814 scfm of air to the aerated lagoon cells. If the design TKN load is included in the analysis, then blowers would need to be sized to deliver 1,219 scfm. The current aeration system consists of two blowers, each with a capacity of 280 scfm. They both are designed to operate as “duty” (i.e. there is no standby blower). The combined maximum capacity of the current blowers is 560 scfm. This would not meet the 2 lbs. O<sub>2</sub>/lb. BOD requirement. The diffuser capacity of the aerated lagoon cells is 640 scfm. This means that even if the capacity of the blowers were adequate, the diffusers themselves could not deliver the required air flow of 1,219 scfm.

After reviewing Lone Tree’s MOR data, the average minimum dissolved oxygen (DO) concentration in their aeration cells has been 6.6 mg/L over the study period. Average spring, summer, fall and winter DO levels are 7.2 mg/L, 3.5 mg/L, 6.5 mg/L and 9.5 mg/L, respectively. These high DO levels are likely a combination of diffused air input from blowers and atmospheric reaeration of surface waters, as the surface area of Lone Tree’s lagoons is very large. This indicates the aerated lagoon cells are being supplied with ample dissolved oxygen for BOD treatment purposes.

## **CURRENT SAMPLING PROCEDURES**

Sampling data and practices at the plant were reviewed. The samples are collected at a structure where the lift station and gravity flow lines mix just ahead of the parshall flume. The plant operator indicates that the sampler is typically set out on a Wednesday morning and collected on Thursday morning. The measured concentration is recorded as the concentration for Thursday in order to match the effluent grab sample taken on Thursday. The flow would be based on the volume calculated by the ultrasonic transducer over the flume. The flow is the totalized flow from midnight Thursday to midnight Friday. Therefore, the samples taken would represent a concentration as collected with volumes from 2/3 from Wednesday and 1/3 from Thursday but would be recorded on the MOR as Thursday with the totalized flow volume being from midnight Thursday to midnight Friday.

## **HIGH FLOW OPERATIONS**

When flows reach approximately 2.0 MGD, the operator opens a gate and allows excess wastewater to flow to a storm cell. Flow to the storm cell is not metered and is not filtered or screened. The storm cell essentially acts as an equalization (EQ) basin. However, there is a suspected leak in this cell because, despite having no known outlet, water will slowly drain itself after high flow events. The storm cell has only been used twice. The existing storm cell has a volume of approximately 3.6 MG. If this cell is to continue to be used, the leak must be addressed and a way to return flow to the plant would need to be added.

## **STREAM CLASSIFICATION**

The State of Iowa has updated the state's water quality standards. Under the rules, all streams in Iowa are classified as fishable and swimmable. Each receiving stream is classified by the Iowa Department of Natural Resources for both recreational use (human contact) and protection of aquatic life. This classification process is known as the use assessment/use attainability analysis (UA/UAA) process. Under this process, it is assumed that all streams receive the highest protection unless the assessments indicate that lesser protection is warranted. The highest protection categories are recreational use Class A1 and aquatic life Class B(WW-1) use designations. The designations for both recreational use and aquatic life are described below.

Waterbody segments designated for recreational use are protected for uses that involve human contact with the water. Three types of recreational use are:

- Class A1 – Primary contact recreational use: The water's recreation uses involve full body immersion with prolonged and direct contact with the water, such as swimming and water skiing.
- Class A2 – Secondary contact recreational use: Water recreation use involve incidental or accidental contact with the water, where the probability of ingesting water is minimal, such as fishing and shoreline activities.
- Class A3 – Children's recreational use: Water recreation uses where children's activities are common, like wading or playing in the water. These waters are commonly located in urban or residential areas where the banks are defined and there is visible evidence of flow.

Warm water waterbodies can also be designated to protect aquatic life, such as fish, plants and insects that live in and around the water. Streams that maintain flow throughout the year, or contain sufficient pooled areas during intermittent flow periods to maintain a viable aquatic community, can be designated for aquatic life uses for warm water species. The three warm water uses include:

- Class B(WW-1) – Typically large interior and border rivers and the lower segments of medium-size tributary streams capable of supporting and maintaining a wide variety of aquatic life, including game fish.
- Class B(WW-2) – Typically smaller, perennially flowing streams capable of supporting and maintaining a resident aquatic community, but lack the flow and habitat necessary to fully support and sustain game fish populations.
- Class B(WW-3) – Intermittent stream with non-flowing perennial pools capable of supporting and maintaining a resident aquatic community in harsher conditions. These waters lack the flow and habitat necessary to fully support and sustain a game fish population.

## **EXISTING EFFLUENT LIMITATIONS**

The Lone Tree WWTF is currently operating under Iowa NPDES Permit Number 5240001. The NPDES permit was issued May 1, 2015, and is set to expire April 30, 2020. The new permit issued to the City indicates the classification for Prairie Creek is Class A2 and Class B(WW-2). The new permit imposes stricter ammonia discharge limitations and requires

disinfection of the City's effluent. The new ammonia limits are presented in the NPDES permit in Appendix A.

An aerated lagoon such as the one serving Lone Tree is typically unable to meet the proposed end of pipe limits on ammonia without enhancement. Because of colder water temperatures in the winter, the conversion of ammonia-nitrogen to nitrate-nitrogen in the wastewater slows, and the ammonia concentration in the effluent rises. This inability to remove ammonia is recognized as a common limitation of the aerated lagoon process. A graph showing effluent ammonia concentrations and effluent ammonia limits is shown in Figure 3-3. As can be seen, effluent ammonia concentrations typically exceed permits limits during the colder months. It is anticipated that the City of Lone Tree will be unable to comply with the proposed ammonia limits using only the current aerated lagoon treatment facility. In addition, the new recreational use designation of A2 will require disinfection of the wastewater treatment plant effluent, which the existing facility is not designed to provide.

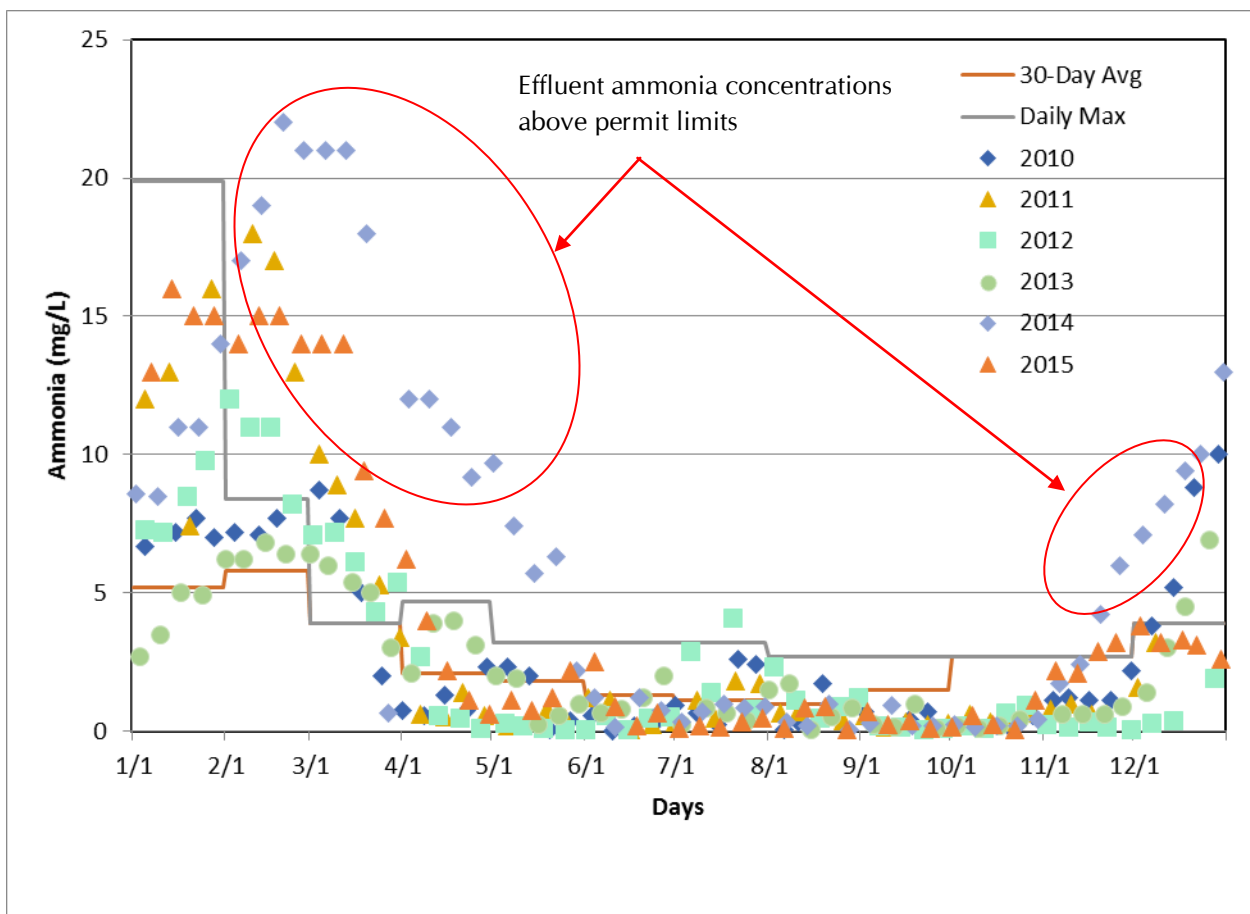

Figure 3-1: Effluent Ammonia Lone Tree, Iowa

A mechanical treatment facility typically is able to consistently meet more stringent ammonia discharge limitations. If the City were to design a mechanical treatment facility, the proposed end of pipe limits would be different than for an aerated lagoon. The end of pipe limits for a mechanical plant are shown in Table 3-2. While these limits are more stringent than a lagoon facility, mechanical plants are typically able to meet these limits.

**Table 3-2 – End of Pipe Limits for Mechanical Facilities**

	Average Concentration (mg/l)	Maximum Concentration (mg/l)	Comments
Ammonia – Nitrogen			
January	5.2	15.2	
February	5.8	14.2	
March	4.5/2.8	14.7	B(WW-1)/B(WW-2)
April	2.1	15.7	
May	1.8	15.2	
June	1.3	14.4	
July	1.1	17.6	
August	1.0	16.2	
September	1.5	16.5	
October	2.8	15.7	
November	3.4	14.7	
December	4.0	16.0	

## **CHAPTER 4 - TREATMENT ALTERNATIVES**

This chapter addresses improvement alternatives to meet new effluent limits outlined in the City's most recent NPDES permit.

Four general types of treatment alternatives were considered for meeting the ammonia effluent limits outlined in the new NPDES operating permit. The general alternatives considered were: 1) continued use of the existing aerated lagoon treatment facility, 2) land application of wastewater effluent, 3) construction of a new mechanical treatment plant, and 4) conversion of the existing aerated lagoon into an enhanced treatment aerated lagoon. All alternatives would require the addition of disinfection.

### **ALTERNATIVE 1 – EXISTING AERATED LAGOON TREATMENT FACILITY**

The City of Lone Tree's new NPDES permit includes water quality based effluent limits for ammonia nitrogen. The new ammonia limits are more restrictive than the previous permit limits. Based upon currently collected data, it is Veenstra & Kimm, Inc.'s opinion that the existing aerated lagoon treatment facility alone is no longer a viable treatment alternative for the City of Lone Tree.

### **ALTERNATIVE 2 – LAND APPLICATION**

Land application of the proposed increase in design loading in addition to any treatment modifications necessary to meet the new limits was evaluated and determined to be economically inefficient and not a viable process option. The existing facility cannot consistently meet the proposed final limits via land application. This is deemed not practical.

### **ALTERNATIVE 3 – MECHANICAL TREATMENT**

Mechanical treatment options could achieve compliance with ammonia limits. A mechanical treatment plant would replace the existing aerated lagoon facility and could be located on the existing grounds. Specifically, the unused lagoon cell on the existing site would be used as the location for a mechanical treatment plant. The current treatment train (i.e. aerated lagoons and quiescent cell) would remain in operation during construction of any mechanical treatment alternative. All mechanical treatment options would require storm water equalization, preliminary treatment, aeration tanks, disinfection and sludge treatment and disposal. Each of these items is discussed below. The new mechanical treatment plant would be designed for the 30-Day Average Wet Weather Flow (AWW 30) of 0.822 MGD.



The mechanical systems reviewed for this report are 3A) Sequencing Batch Reactor Treatment System from Fluidyne Corporation and 3B) SEQUOX Treatment Process by Aero-Mod, Inc. The proposals for these two systems are included in Appendix D.

**Biosolids Removal:** The plant operator performed sludge judging in the aerated lagoon cells and estimated 2.5 feet of solids in Aerated Lagoon Cell 1 and 1.5 feet of solids in Aerated Lagoon Cell 2. Because the mechanical treatment alternatives utilize the existing lagoon structure for equalization, removal of all biosolids should be considered. A cost for biosolids removal has been included with all mechanical treatment alternatives.

**Equalization Basin:** During construction, the existing aerated lagoon system would remain in operation. After construction of the new mechanical treatment plant, the floating baffle in the aerated lagoon cells would be removed and the cells would be utilized as a storm water equalization basin. A stormwater equalization basin stores flows in excess of the treatment capacity of the plant (AWW 30). When the peak flows subside, the stored water is returned to the treatment plant for treatment and discharge. Without an equalization basin, the plant would be sized based on peak hour flows. This would be more expensive for the City to construct and more difficult for the City to operate. The concept of a mechanical treatment plant without an equalization basin was not evaluated in detail after it was determined the concept was significantly more expensive than a new mechanical treatment plant with a flow equalization. Veenstra & Kimm, Inc. recommends that an equalization basin be included with the mechanical treatment plant option.

To utilize the lagoon for flow equalization, a diversion structure would need to be constructed to divert flows over the plant capacity to the equalization basin. A stormwater return lift station with metering would be constructed in the northwest corner of the existing aerobic lagoon structure to return flows for treatment after high flows have subsided. The aeration system in the lagoon cell would be abandoned and any biosolids in the cell would be removed. The cost of flow equalization is included with all mechanical treatment plant alternatives.

**Preliminary Treatment:** Preliminary treatment would remove large items such as rags, sticks, floatables, grit and other items that can cause mechanical problems and excessive wear from abrasion. The preliminary treatment would include a mechanical screen to remove larger solids from the wastewater and grit removal equipment. A masonry building would be constructed to house the preliminary treatment equipment. The building could also be sized to include any additional equipment such as blowers and electrical equipment/controls. Proposals for a stair screen, spiral screen and grit removal system can be found in Appendix C. The cost of a stair screen and grit removal system are included with all mechanical plant alternatives.

**Solids Disposal:** All mechanical plants generate biosolids and solids as a byproduct of wastewater treatment. Solids removed during preliminary treatment are typically not usable products and are hauled as trash to the nearest landfill. Biosolids and solids that are not removed in preliminary treatment, or are generated during the treatment process, are removed during clarification of the effluent. These solids are generally referred to as sludge. The sludge removed during effluent clarification needs to be treated and stored at the wastewater plant site until it can be disposed of properly.

Some disposal methods for sludge include incineration, landfilling, and land application. Because of the availability of farmland in Iowa, land application is the typical method for sludge disposal. When land application of sludge is used, the Iowa Department of Natural Resources requires a minimum of 180 days of sludge storage at the plant site. Typically, Veenstra & Kimm, Inc. recommends 365 days of sludge storage for land application flexibility. However, for the City of Lone Tree Veenstra & Kimm, Inc. recommends starting with 180 days of sludge storage and building additional storage as the City grows and/or as required for land application flexibility. For land application, sludge stored at the plant is removed in the spring and/or fall each year and transported to a farm field where it is applied to the land. The sludge generated by the processes considered in this report will be Class B sludge. Land application of Class B sludge is done by "injection" of the sludge into the ground. Injection is accomplished by placing the sludge beneath the surface of the earth using special equipment or by incorporating the sludge using plows or disks immediately after surface application. No equipment for sludge hauling is included with these alternatives as solids disposal is typically performed by a professional sludge hauling company. If the City wishes to perform its own sludge disposal, additional equipment will be necessary.

**Disinfection:** Because Lone Tree's new NPDES permit includes *E. coli* effluent limits, the City will need to add disinfection before final effluent discharges to the receiving stream. Veenstra & Kimm, Inc. recommends the City include effluent disinfection as part of the wastewater treatment facility improvements by installing ultraviolet (UV) disinfection. UV disinfection would be installed after the last treatment process and before discharging to the receiving stream. The cost for constructing UV disinfection is included in all treatment alternatives in this chapter. Typically, UV disinfection has been preferred over methods such as chlorination/dechlorination due to its low cost and ease of operation. Chlorination/dechlorination was not explored for this report. For mechanical treatment alternatives with flow equalization, the peak flow rate is assumed to be the AWW flow (0.822 MGD). Since the peak discharge rate from the SBR system is 1,600 gpm (2.3 MGD), a larger disinfection system was considered for that alternative. The basis of design for UV disinfection was a horizontal UV system.

### ALTERNATIVE 3A – SEQUENCING BATCH REACTOR

A Sequencing Batch Reactor (SBR) facility is a type of activated sludge plant. SBR systems require preliminary treatment (screening and grit removal). The SBR differs from traditional activated sludge in that the tanks are operated in a fill and draw mode and provide aeration and clarification in a single unit process. In the system proposed for the City of Lone Tree, wastewater flows by gravity to the preliminary treatment building. Wastewater from the preliminary treatment building then flows to the aeration tanks where it is treated. Periodically, the air supply to the aeration tanks is cycled off and the tank contents are allowed to settle. The clarified effluent is then decanted. The effluent flows through the disinfection units and is discharged to the receiving stream.

The sequencing batch reactor process does not require construction of individual clarifiers since the settling process is accomplished within the aeration tanks. Ammonia removal is also accomplished since aeration and mixing are independently controlled. This minimizes the structures needed for the mechanical plant.

As part of the process, the wastewater sludge in the aeration tanks is drawn out of the tanks and must be processed prior to land application. The sludge will be sent directly from the aeration tanks to an aerobic digester. The sludge will be aerobically digested and then stored. Since land application will be the method of sludge disposal, the Iowa Department of Natural Resources requires a minimum of 180 days of sludge storage at the plant site. The ISAM/SBR proposal estimates approximately 240 days of sludge storage in the treatment process. Since the estimated 240 days of process storage represents the storage capacity of the system in design year 2038 and exceeds the IDNR requirements of 180 days, Veenstra & Kimm, Inc. does not recommend constructing an additional sludge storage tank immediately. Veenstra & Kimm, Inc. recommends reevaluating the sludge storage needs should the City have difficulty in accommodating a twice per year land application period. No additional sludge storage is recommended at this time.

The costs for constructing a sequencing batch reactor mechanical treatment facility are shown in Table 4-1. More details on this process and a site layout are provided in the preliminary proposal provided in Appendix D. The estimated cost for construction of a sequencing batch reactor mechanical treatment facility is approximately \$5,058,000. A general site plan for the SBR system is shown in Figure 4-1.

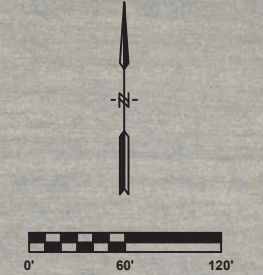

KEY	
TRUNK SEWER	
EFFLUENT SEWER	
WATER MAIN	
NEW STRUCTURES	



VEENSTRA & KIMM, INC.

**SBR SITE PLAN  
LONE TREE, IOWA  
FIGURE 4-1**

**Table 4-1: Sequencing Batch Reactor Mechanical Plant Cost Estimate**

Biosolids Removal	\$395,000
EQ Lift Station & Earthwork	\$249,000
Equalization Lift Station	\$100,000
Preliminary Treatment (screens, grit, building)	\$653,000
SBR Equipment	\$866,000
SBR Tanks	\$688,000
Site Work	\$250,000
UV Disinfection	\$153,000
Electrical & Controls	\$400,000
<u>Generator</u>	<u>\$70,000</u>
<i>Sub-Total</i>	<i>\$3,824,000</i>
<u>Contingency (15%)</u>	<u>\$574,000</u>
<b>Estimated Construction Cost</b>	<b>\$4,398,000</b>
<u>Engineering, Legal, Admin. (15%)</u>	<u>\$660,000</u>
<b>Estimated Project Cost</b>	<b>\$5,058,000</b>

ALTERNATIVE 3B – SEQUOX

Aero-Mod’s SEQUOX Process is a continuous flow activated sludge process. The ammonia reduction occurs by cycling of the aeration in the aeration basins. The cycling creates alternating aerobic and anoxic conditions that promote nitrification and denitrification (ammonia and total nitrogen reduction).

In the system proposed for the City of Lone Tree, wastewater flows by gravity to the preliminary treatment building. Wastewater from the preliminary treatment building then flows to the aeration tanks where it is treated. Water flows through a series of aeration basins and on to final clarifiers. From the clarifiers, treated effluent flows through the disinfection units and is discharged to the receiving stream.

As part of the process, the wastewater sludge in the clarifiers is drawn out of the tanks and must be processed prior to land application. The sludge will be digested in aerobic digesters which are part of the overall Aero-Mod process. The digesters also provide some thickening benefits through decanting. Once the sludge has been stabilized through digestion, the sludge will be stored. Since land application will be the method of sludge disposal, the Iowa Department of Natural Resources requires a minimum of 180 days of sludge storage at the plant site. Veenstra & Kimm, Inc. recommends 365 days of sludge storage for land application flexibility. For SBR comparison purposes, a sludge storage tank for the SEQUOX alternative was sized to hold 240 days of solids. The SEQUOX proposal estimates approximately 1,525 gallons of solids will be produced per day (gpd). At this rate, a 366,000-gallon sludge storage tank would be needed to provide 240 days of storage. As with the SBR alternative, since the estimated 240 days of storage represents the storage capacity of the SEQUOX system in design year 2038, and since the 240 days

of storage exceeds the IDNR requirements of 180 days, Veenstra & Kimm, Inc. does not recommend constructing additional sludge storage capacity, beyond the 240 days of storage. Veenstra & Kimm, Inc. recommends reevaluating the sludge storage needs of the WWTF in 10-15 years.

The costs for constructing a SEQUOX mechanical treatment facility are shown in Table 4-2. More details on this process are provided in the preliminary proposal provided in Appendix D. The estimated cost for construction of a SEQUOX mechanical treatment facility is approximately \$5,720,000. A general site plan for the Aero-Mod system is shown in Figure 4-2.





**Table 4-2: Aero-Mod Mechanical Plant Cost Estimate**

Biosolids Removal	\$395,000
EQ Lift Station & Earthwork	\$249,000
Influent Lift Station	\$100,000
Preliminary Treatment (screens, grit, building)	\$653,000
SEQUOX Equipment	\$1,176,000
Concrete Tank Cost	\$765,000
Sludge Storage Tank Cost (50'x40'x14')	\$167,000
Site Work	\$250,000
UV Disinfection (AWW 0.822 mgd)	\$100,000
Electrical & Controls	\$400,000
<u>Generator</u>	<u>\$70,000</u>
<i>Sub-Total</i>	<i>\$4,325,000</i>
<u>Contingency (15%)</u>	<u>\$649,000</u>
<b>Estimated Construction Cost</b>	<b>\$4,974,000</b>
<u>Engineering, Legal, Admin. (15%)</u>	<u>\$746,000</u>
<b>Estimated Project Cost</b>	<b>\$5,720,000</b>

#### **ALTERNATIVE 4 – ENHANCED TREATMENT AERATED LAGOON PROCESS**

Under this alternative, the existing aerated lagoon treatment facility would be converted to an enhanced treatment aerated lagoon process. The existing aerated lagoon cells would be used, but additional equipment would be incorporated to increase the nitrification for greater ammonia reductions typically seen in an activated sludge process. Three system manufacturers were contacted by Veenstra & Kimm, Inc. for consideration at Lone Tree's facility. The systems reviewed for this report were 4A) OPTAER/SAGR Wastewater Treatment System by Nexom, Inc., 4B) LemTec™ Biological Treatment Process by Lemna Technologies, Inc. and 4C) IDEAL Aeration-Mixing Systems by Environmental Dynamics International. The proposals for all three systems are included in Appendix E.



KEY	
TRUNK SEWER	
EFFLUENT SEWER	
WATER MAIN	
NEW STRUCTURES	



VEENSTRA & KIMM, INC.

AERO-MOD SITE PLAN  
LONE TREE, IOWA  
FIGURE 4-2

All processes utilize similar technology. The existing lagoon system is utilized to create different areas of mixing and aeration. In some of the alternatives, the cells are also covered with an insulated material to prevent heat loss. The phased mixing and aeration promotes the growth of different types of microorganisms to treat the wastewater. The alternatives also include media that microorganisms can attach to and grow on (fixed film process). The fixed film process provides additional ammonia removal to meet the lower ammonia limits proposed for aerated lagoons.

**Biosolids Removal:** The plant operator performed sludge judging in the aerated lagoon cells and estimated 2.5 feet of solids in Aerated Lagoon Cell 1 and 1.5 feet of solids in Aerated Lagoon Cell 2. Because the Enhanced Treatment Aerated Lagoon alternatives utilize the existing lagoon structure, removal of all biosolids should be performed. A cost for biosolids removal has been included with all of the enhanced treatment aerated lagoon alternatives.

**Disinfection:** Because Lone Tree's new NPDES permit includes *E. coli* effluent limits, the City will need to add disinfection before final effluent discharges to the receiving stream. Veenstra & Kimm, Inc. recommends the City include effluent disinfection as part of the wastewater treatment facility improvements by installing ultraviolet (UV) disinfection. UV disinfection would be installed after the last treatment process and before discharging to the receiving stream. The cost for constructing UV disinfection is included in all treatment alternatives in this chapter. Typically, UV disinfection has been preferred over methods such as chlorination/dechlorination due to its low cost and ease of operation. Chlorination/dechlorination was not explored for this report.

#### ALTERNATIVE 4A – OPTAER WASTEWATER TREATMENT SYSTEM

For this alternative, the existing lagoon infrastructure would be retained for primary and secondary treatment. No screening or grit removal is required for this alternative. In the aerated lagoon cells, the existing floating baffle would be removed and replaced with a floating geomembrane baffle curtain. The Quiescent Cell would be divided into two zones (one partial mix zone and one settling zone) using a floating geomembrane baffle curtain. An OPTAER fine bubble partial mix aeration system would be implemented in the newly divided cells 1a, 1b and 2a. The northwest cell which is currently used for stormwater would be filled in and the Submerged Attached Growth Reactor (SAGR) cells installed. Specifically, a four (4)-cell aerated Horizontal Flow SAGR® system for nitrification (ammonia removal) would be constructed following Cell 2b.



In the OPTAER system, flow would enter the enhanced lagoon system through the partially mixed aerated lagoon Cell 1a and 1b. Water would then flow to partially mixed aerated lagoon Cell 2a. In the partially mixed cells, varying levels of air and mixing are used to provide both nitrification (ammonia removal) and traditional reductions of BOD and TSS. Water would then flow to Cell 2b for settling prior to the SAGR cells. Water then flows to the SAGR cells for additional ammonia removal. After exiting the SAGR, water would flow to a UV disinfection chamber and be discharged to the receiving stream. More detail on this process and a site layout is provided in the preliminary proposal provided in Appendix E. An estimate of the costs associated with the OPTAER process is presented in Table 4-3. This OPTAER system is based on the IDNR Mods 3 changes. The cost for constructing the OPTAER Wastewater Treatment System enhanced treatment aerated lagoon is \$3,986,000. A general site plan for the OPTAER/SAGR system is shown in Figure 4-3.





**Table 4-3: OPTAER Wastewater Treatment System Cost Estimate**

Biosolids Removal	\$395,000
OPTAER Equipment	\$1,086,000
Blower Building (20'x20')	\$96,000
SAGR Media/Mulch/Other Materials	\$720,000
Bentonite Liner for Storm Cell	\$294,000
UV Disinfection (MWW 2.224 mgd)	\$153,000
Electrical	\$200,000
<u>Generator</u>	<u>\$70,000</u>
<i>Sub-Total</i>	<i>\$3,014,000</i>
<u>Contingency (15%)</u>	<u>\$452,000</u>
<b>Estimated Construction Cost</b>	<b>\$3,466,000</b>
<u>Engineering, Legal, Admin. (15%)</u>	<u>\$520,000</u>
<b>Estimated Project Cost</b>	<b>\$3,986,000</b>

#### ALTERNATIVE 4B – LEMTEC™ BIOLOGICAL TREATMENT PROCESS

The LemTec™ Biological Treatment Process does require preliminary treatment. Specifically, the LemTec process requires screening, but not grit removal. The LemTec proposal assumes a 12-foot water depth in each of the LemTec treatment lagoons. Since the current quiescent lagoon and storm cell are only have a water depth of 8 feet, earthwork will be needed as part of this alternative.



KEY	
TRUNK SEWER	
EFFLUENT SEWER	
WATER MAIN	
NEW STRUCTURES	



VEENSTRA & KIMM, INC.

OPTAER/SAGR SITE PLAN  
LONE TREE, IOWA  
FIGURE 4-3

Preliminary treatment would remove large items such as rags, sticks, floatables and other items that can cause mechanical problems and excessive wear from abrasion. The preliminary treatment would include a mechanical screen to remove larger solids from the wastewater. A masonry building would be constructed to house the preliminary treatment equipment. The building could also be sized to include any additional equipment such as blowers and electrical equipment/controls. The cost of preliminary treatment is included in the cost estimate below.

The proposed design for Lone Tree utilizes two of the existing lagoons in parallel to handle a total design flow of 0.370 MGD. Each LemTec lagoon is divided into three cells using Lemna's custom designed LemTec™ Reverse Miter Hydraulic Baffle, which will be installed to minimize short-circuiting between each cell. The first cell in each lagoon will be a completely mixed cell. The second cell in each lagoon will be a partially mixed cell. The third cell in each lagoon will be a settling zone.

The complete mix zone of the LBTP process is an aerated, aggressively mixed cell that establishes an environment suitable for the rapid removal of BOD<sub>5</sub> by heterotrophic bacteria. In addition to BOD<sub>5</sub> removal, ammonia is also removed by heterotrophic bacteria present in the complete mix cell. Ammonia is utilized by the bacteria to support its nitrogen requirement for growth. Also, nitrifier growth will occur in the complete mix cell resulting in additional (and significant) ammonia reduction.

Following the complete mix cell, water will flow into partial mix cells that utilize low-rate diffusers. The partial mix cells require lower levels of aeration and mixing in order to effectively achieve BOD<sub>5</sub> removal. The last cell in both lagoons will be a settling zone with a detention time of 2.9 days. Low rate diffusers will be installed to provide additional aeration. All the cells in the proposed design will be covered by Lemna's LemTec™ Modular Insulated Cover rated at R10. The LemTec™ Cover prevents algae growth by eliminating sunlight below the cover and improves clarification in two ways: 1) it prevents wind action on the water surface thereby establishing a quiescent zone for solids to settle, and 2) the insulation minimizes seasonal and diurnal temperature fluctuations, thereby reducing stirring by thermal currents. The LemTec™ Cover improves TSS removal, provides algae prevention and encourages nitrification by regulating temperatures within the ponds.

Following the ponds, the LemTec™ Polishing Reactor will provide additional BOD and ammonia treatment. The LemTec™ Polishing Reactor (LPR) consists of submerged, attached-growth media modules used for maintaining an adequate population of bacteria. The LPR enhances the growth of nitrification bacteria to encourage conversion of ammonia to nitrates in an aerobic environment. Aeration is provided by rack-mounted coarse-bubble diffusers located under the media, which evenly distribute the air and shear coarse bubbles into very fine bubbles. The LPR produces BOD and TSS effluent levels less

than 10 mg/l and NH<sub>3</sub>-N as low as 1 mg/l. Typically housed in a concrete or metal structure near the effluent of the pond, the LPR is the final stage of the lagoon based LemTec Biological Treatment Process.

After exiting the reactor, water would flow to a UV disinfection chamber and through a new effluent flume. Finally, water will be discharged to the receiving stream. More detail on this process and a site layout is provided in the preliminary proposal provided in Appendix E. An estimate of the costs associated with the LemTec process is presented in Table 4-4. The cost for constructing the LemTec™ Biological Treatment Process enhanced treatment aerated lagoon is \$5,027,000. A general site plan for the LemTec system is shown in Figure 4-4.

**Table 4-4: LemTec Wastewater Treatment System Cost Estimate**

Biosolids Removal	\$395,000
Preliminary Treatment (screens & building)	\$481,000
Lemna Equipment	\$1,826,000
Earthwork	\$292,000
Bentonite Lining of Unused Cell	\$294,000
Replacement of 12" pipe with 16" pipe	\$90,000
UV Disinfection (MWW 2.224 mgd)	\$153,000
Electrical	\$200,000
<u>Generator</u>	<u>\$70,000</u>
<i>Sub-Total</i>	<i>\$3,801,000</i>
<u>Contingency (15%)</u>	<u>\$570,000</u>
<b>Estimated Construction Cost</b>	<b>\$4,371,000</b>
<u>Engineering, Legal, Admin. (15%)</u>	<u>\$656,000</u>
<b>Estimated Project Cost</b>	<b>\$5,027,000</b>

#### ALTERNATIVE 4C – IDEAL BIOREACTOR

The IDEAL Bioreactor by EDI requires preliminary treatment and flow equalization. Preliminary treatment would remove large items such as rags, sticks, floatables, grit and other items that can cause mechanical problems and excessive wear from abrasion. The preliminary treatment would include a mechanical screen to remove larger solids from the wastewater and grit removal equipment. A masonry building would be constructed to house the preliminary treatment equipment. The building could also be sized to include any additional equipment such as blowers and electrical equipment/controls.

After preliminary treatment, two parallel IDEAL Bioreactors are placed within the existing northwest cell footprint. An additional portion of this cell can be used as post-treatment equalization. Both IDEAL bioreactors will operate in parallel, receiving constant influent flow split evenly between the two. Each basin will operate on opposing operation/aeration schedules, allowing for airflow to be redirected from one basin to the other every two



VEENSTRA & KIMM, INC.

LEMTEC SITE PLAN  
LONE TREE, IOWA  
FIGURE 4-4

hours, rather than turning blowers off and on. Once the IDEAL reactors begin operation, the existing aeration cells will no longer be needed for treatment. As such, they will be used to store flows in excess of the design AWW flow. Biosolids waste from the IDEAL process will be aerobically digested and stored in the existing Quiescent Cell. Eventually, biosolids from this cell will need to be removed and land applied. Treated wastewater leaving the IDEAL system will be disinfected prior to discharge to the receiving stream. More detail on this process and a site layout is provided in the preliminary proposal provided in Appendix E. An estimated project cost for the IDEAL system is presented in Table 4-5. The estimated project cost for the IDEAL system is \$4,484,000. A general site plan for the IDEAL system is shown in Figure 4-5.

**Table 4-5: IDEAL Bioreactor Wastewater Treatment System Cost Estimate**

Biosolids Removal	\$395,000
EQ Lift Station & Earthwork	\$249,000
Preliminary Treatment (screens, grit, building)	\$653,000
IDEAL Equipment	\$874,000
Bentonite Lining of Unused Cell	\$294,000
Aerobic Digester Lagoon Aeration & Blower Equipment	\$465,000
Replacement of 12" pipe with 16" pipe	\$90,000
UV Disinfection (AWW 0.822 mgd)	\$100,000
Electrical	\$200,000
<u>Generator</u>	<u>\$70,000</u>
<i>Sub-Total</i>	<i>\$3,390,000</i>
<u>Contingency (15%)</u>	<u>\$509,000</u>
<b>Estimated Construction Cost</b>	<b>\$3,899,000</b>
<u>Engineering, Legal, Admin. (15%)</u>	<u>\$585,000</u>
<b>Estimated Project Cost</b>	<b>\$4,484,000</b>





## SUMMARY OF AMMONIA ALTERNATIVES

A total of seven alternatives were identified and evaluated for the City of Lone Tree's wastewater treatment facility; however, only five of these alternatives were considered viable. A summary of the project costs for each of the alternatives is shown in Table 4-6.

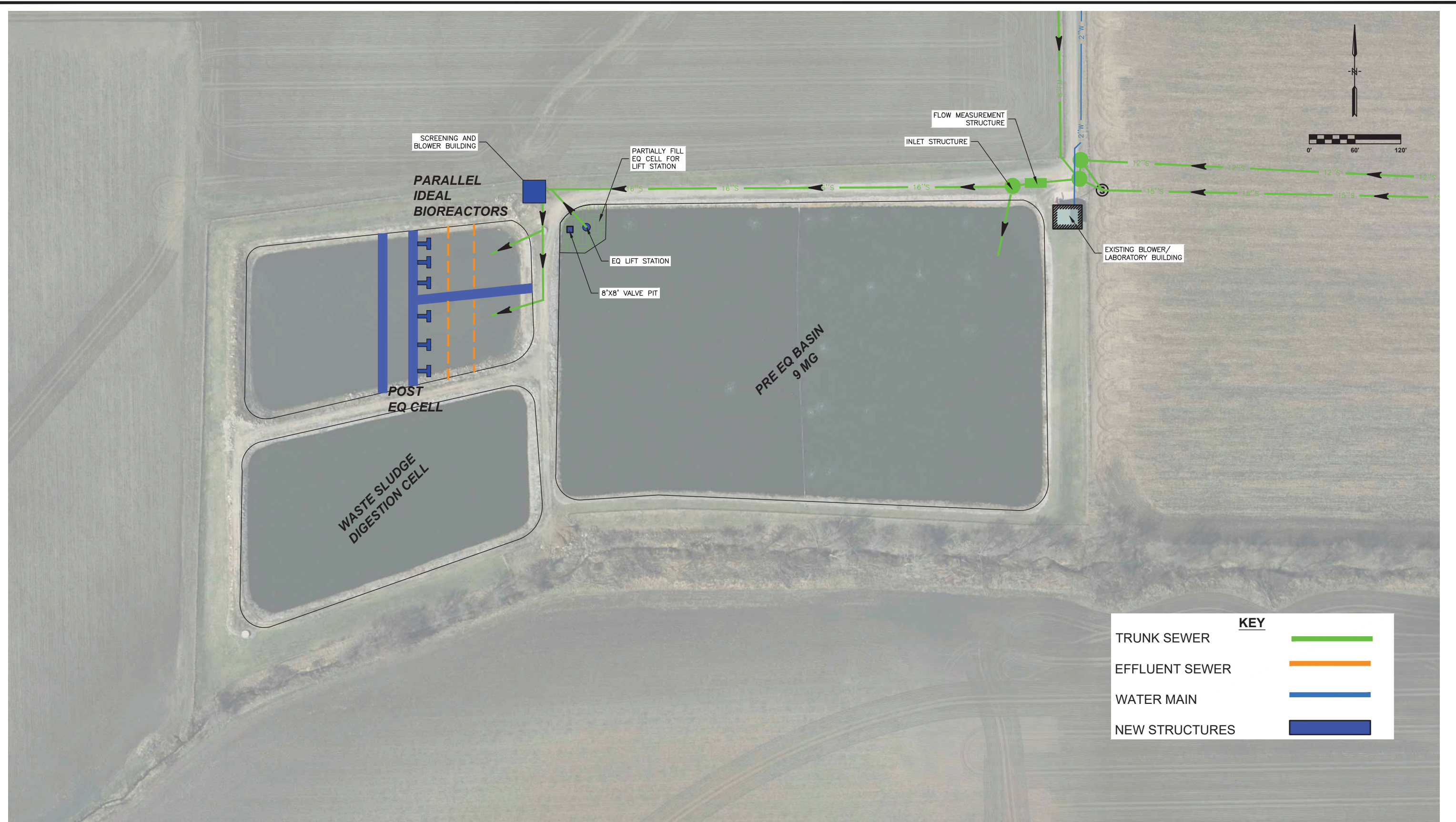
**Table 4-6: Summary of Estimated Project Costs for Each Treatment Alternative**

1) Existing Aerated Lagoon	n/a
2) Land Application of Effluent	n/a
3) Mechanical Treatment	
3A) Sequencing Batch Reactor	\$5,058,000
3B) Aero-Mod SEQUOX	\$5,720,000
4) Enhanced Aerated Lagoon Treatment	
4A) OPTAER/SAGR	\$3,986,000
4B) LemTec	\$5,027,000
4C) IDEAL	\$4,484,000



KEY	
TRUNK SEWER	
EFFLUENT SEWER	
WATER MAIN	
NEW STRUCTURES	



VEENSTRA & KIMM, INC.

IDEAL SITE PLAN  
LONE TREE, IOWA  
FIGURE 4-5

In addition to capital cost, each of the alternatives will have an annual operation and maintenance (O&M) cost. The annual cost for O&M will vary with the type of facility. The mechanical treatment facilities and some of the enhanced treatment aerated lagoon facilities will have higher annual O&M costs. The OPTAER/SAGR enhanced treatment aerated lagoon system will have lower annual O&M costs. The annual O&M costs for each alternative essentially correlates with that alternatives project cost (i.e. higher project cost, higher O&M). The alternatives with the highest capital cost have the highest annual O&M costs. Likewise, the least costly alternatives to construct have lower annual O&M costs.

## **DISCUSSION OF ALTERNATIVES**

The existing aerated lagoon facility will not be able to meet the effluent limits that have been given by the Iowa Department of Natural Resources. It is Veenstra & Kimm, Inc.'s opinion that the existing aerated lagoon treatment facility is no longer a viable treatment alternative for the City of Lone Tree unless improvements are made. Land application of the effluent was also not deemed a viable alternative.

Each of the remaining alternatives that were identified for the City of Lone Tree has distinct advantages and disadvantages. Each of the remaining alternatives has an estimated capital cost as well as an annual operating cost. Based on the advantages and disadvantages of each of the remaining alternatives, an analysis and evaluation was completed to determine the preferred alternative.

Alternative 3 involves constructing a new mechanical wastewater treatment plant. Two types of mechanical plants were considered: 1) a Sequencing Batch Reactor (SBR) Mechanical Plant and 2) Aero-Mod SEQUOX Mechanical Treatment Plant. Both types of mechanical plants would require an equalization basin to handle flows greater than 0.822 MGD, preliminary treatment equipment and UV disinfection. They would also require solids disposal and a Grade III wastewater treatment plant operator. The City's current plant requires only a Grade II operator. Some of the disadvantages associated with a new mechanical wastewater treatment plant include having to provide solids disposal, the higher capital cost of construction and the higher O&M costs. Current City staff would also need additional training to achieve the Grade III Operator's license or a new Grade III Operator would need to be hired.

Alternative 4 involves converting the aerated lagoon treatment facility into an enhanced treatment aerated lagoon facility. Three processes were considered: 1) the OPTAER/SAGR process by Nexom, Inc., 2) the LemTec™ process by Lemna Technologies, Inc and 3) the IDEAL process by Environmental Dynamics International. All three processes require UV



disinfection, and the IDEAL process requires flow equalization. Of these processes, the IDEAL and OPTAER/SAGR systems have essentially the same capital costs while the OPTAER/SAGR system has the lowest annual O&M costs. The key disadvantage of the IDEAL system is using the quiescent cell for aerobic sludge storage. Use of lagoons to store solids is not an IDNR approved way of handling solids. Furthermore, when the lagoon is full, solids will have to be removed and land applied. Although this will not occur often, there will be a substantial cost associated with the removal of biosolids from the storage lagoon.

### **SELECTED ALTERNATIVE**

Through discussion with the City, it was decided that a mechanical plant offered the best ability for long-term flexibility and ability to accommodate possible future nutrient discharge limits with regard to total nitrogen and phosphorus. Of the two mechanical treatment facilities included in this evaluation, the City selected Aero-Mod SEQUOX as the mechanical treatment system that would best suit its needs with regard to operation and maintenance of a mechanical facility. There are currently in excess of 30 Aero-Mod facilities operating in the State of Iowa and it is a known technology which has consistently met NPDES permit limits similar to those which will be required in Lone Tree. This type of treatment also is able to achieve significant total nitrogen removal which may become part of a future permit.

The Aero-Mod treatment alternative included provisions for flow equalization, preliminary treatment, ultraviolet disinfection and sludge storage. Flow equalization will be provided by utilizing the existing aerated lagoon cell and constructing a lift station to return flows for treatment. Construction of a preliminary treatment building including screening and grit removal, as well as areas to house the aeration blowers and electrical/controls is part of this alternative. Ultraviolet disinfection will be constructed downstream of the Aero-Mod process tanks. Finally, sludge storage providing 240 days of storage will be constructed. A layout of this facility was previously presented in Figure 4-2. The Aero-Mod SEQUOX alternative is estimated to cost \$5,720,000 including design and construction of the facility.

## CHAPTER 5 - ENVIRONMENTAL IMPACT

### GENERAL

This chapter will describe more specific impacts, both positive and negative, which will result from the implementation of the wastewater treatment facilities improvements. It is divided into four parts: Natural Environment, Socio-Economic Factors, Sensitive Areas, and Irretrievable and Irreversible Commitment of Resources.

### NATURAL ENVIRONMENT

#### WATER QUALITY

The primary goal of the recommended wastewater treatment facilities improvements is to improve the water quality in the area streams. The improvements to the existing treatment facilities will provide the necessary treatment facilities to handle the community's wastewater treatment needs and to comply with state and federal water quality standards.

Construction of the recommended wastewater treatment facilities improvements may impact the area's surface water supplies temporarily. Excavated materials may be introduced into streams during periods of heavy rains or winds or during construction of the wastewater treatment facilities improvements. Measures to prevent construction runoff include excavating the smallest areas of land for the shortest amount of time or applying mulch to exposed areas. Also, the existing wastewater treatment facilities will be in operation at all times during construction of the recommended improvements to protect the water quality of the receiving stream.

#### AIR QUALITY

Air quality in Lone Tree will be temporarily impacted by fugitive dust produced during construction depending on weather or soil conditions. Some precautions will be necessary to avoid serious impact on air quality. Spraying earth mounds with water or other dust retardants and excavating the minimum amounts of land are two solutions.

Population growth and development will impact air quality through increased sources of pollution. Automobile ownership and use will increase, thus increasing emissions. Continued advancements by the auto industry to reduce emissions and continued regulation of emissions by EPA will also promote air quality goals. Industrial development may create additional point sources of pollution; however, those emissions will be regulated by the Iowa Department of Natural Resources to help achieve and ultimately maintain ambient air quality in Lone Tree.

## NOISE

Noise impacts will be short term and associated with construction. Depending on when construction occurs, residences and businesses near the existing treatment facilities may be affected by heavy equipment noise. No long term impacts are anticipated, however, since noise producing equipment or facilities will be located away from residential development or contained within structures.

## ENERGY

An increase in energy consumption is anticipated as a result of the implementation of the recommended improvements. The operation of the upgraded treatment facilities will increase the demand for electricity.

Future development will also place increased demands on energy. Measures to reduce energy consumption include building more energy efficient homes and landscaping. Advanced developments in alternative forms of energy, such as wind or solar, may make those sources more economically feasible in the future.

## **SOCIO-ECONOMICAL FACTORS**

### POPULATION

Implementation of the recommended improvements will indirectly affect population growth. The additional capacity in the treatment facilities may promote new residential, commercial and industrial growth. The creation of new jobs or housing opportunities will help attract people to the community.

### ECONOMY

The recommended improvements will result in a positive impact on the community's economy. Lone Tree will be able to market itself as having complied with water quality management objectives in order to seek new investment in the area. New firms attracted to the area will create new jobs as well as increase the tax base. The community will also benefit from employment opportunities directly associated with construction of the treatment facilities.

Negative impacts associated with the recommended improvements will be the costs to the users for construction, and operation and maintenance of the expanded facilities. Sewer fees per household will increase; however, by maximizing the use of the existing treatment facilities, the costs will be reduced.

## LAND USE

The recommended improvements will result in both short term and long term impacts on land use. The improvements will temporarily affect land adjacent to the treatment facility and along the sewer routes.

Long term impacts on land use will result from future growth in the community. Development will expand into agricultural areas and the productivity of the land will be lost. The conversion of farmland, however, will not significantly impact the amount of land available in the area for agricultural purposes.

## **SENSITIVE AREAS**

### WILDLIFE HABITATS

A direct benefit of the recommended improvements will be an improved environment for aquatic and terrestrial wildlife due to the improved water quality. Construction of the facilities may temporarily affect wildlife habitats, but long term impacts should be minor.

Any future development anticipated in the community may have a greater impact on wildlife. Future development may encroach on wildlife habitats existing in undeveloped areas. Buildings and paved surfaces may adversely affect stream habitats by removing bank cover, resulting in increased runoff, siltation, or bank erosion. Some species may become more vulnerable to predators by removing burrowing or nesting areas. New roads may present barriers to seasonal movements of some species or separate them from food sources. Urbanization can also impact common "urban" wildlife where more intensive human activity on the ground may affect nesting areas.

Means of minimizing impacts to wildlife habitats include cutting the minimum swath of vegetation for trenching and pipe placement; aligning piping which minimize the taking of young and mature trees; filling and regrading backfill material as soon as possible after trenching; using cover material that is equal in quality to the topsoil removed during excavation; replanting excavated areas with materials native to the disturbed areas or otherwise well suited to it; and inspecting replantings and erosion control measures to ensure successful regeneration to plant materials.

### RARE AND ENDANGERED SPECIES

Little impact is foreseen on rare or endangered species due to the implementation of the recommended improvements. Since construction of the treatment facilities improvements will occur in developed or cultivated areas, no impact is anticipated on endangered species.

### CULTURAL RESOURCES

No archaeological sites in or around the Lone Tree Wastewater Treatment Facility are expected. A copy of this report will be submitted to the State Historical Preservation Office for approval prior to the construction of any facilities.

### RECREATIONAL AND OPEN SPACE

No impact on recreation areas are anticipated from construction of the proposed improvements.

### **IRRETRIEVABLE AND IRREVERSIBLE COMMITMENT OF RESOURCES**

Land, energy and materials are the greatest areas of resource commitment. No additional land will be required for this project. Energy in various forms will be utilized during construction, operation and maintenance of the facilities. The commitment of resources must be weighed in light of the anticipated water quality and socio-economic benefits resulting from the upgrading and expansion of the existing treatment facilities.

## CHAPTER 6 - FINANCING

### GENERAL

This section of the report develops a financing plan for the proposed improvements that has been recommended in this Facility Plan. The intention of this financing plan is to be only a rough guide and not to take place of the detailed program which will be developed by the City's bonding attorney and financial counsel.

The financing plan is necessary so that the wastewater utility can carry out its primary responsibility which is to produce a high quality effluent to meet its NPDES permit requirements. The wastewater utility must also function as a business in that revenues generated from water sales and other miscellaneous items must cover all operating and maintenance costs, equipment replacement, capital improvement projects, all outstanding debt, and maintain a reasonable surplus in case of emergencies.

### METHODS OF FINANCING

In general, most wastewater improvement projects are financed through one of the following methods or a combination of the following methods: general obligation bonds, revenue bonds, special assessment bonds, general obligation bonds abated through revenues, State Revolving Fund (SRF) and utility fund reserves.

#### GENERAL OBLIGATION BONDS

General Obligation Bonds are supported by ad valorem tax on real properties within the corporate limits of the city. As the name indicates, after the issuance of the bonds their repayment becomes a general obligation of the entire city's taxpayers. This method of financing is used for projects that are viewed as being beneficial to the entire population. The Code of Iowa states that the city may bond up to 5% of its actual value of taxable property. Because G.O. bonds are secured by the general tax base, they receive more favorable treatment in terms of interest rate when compared with other financial instruments. In general, general obligation bonds require an approving vote of 60% of the total votes cast. However, since wastewater improvements come under the category of essential corporate purpose, a public referendum is not needed if the Council follows procedures detailed in Iowa Code Section 384.25 entitled "General Obligation Bonds for Essential Purposes."

#### REVENUE BONDS

Revenue Bonds are paid through surpluses in the particular utility fund and are usually funded through increases in rates. These bonds are not supported by general taxation and, therefore, are viewed as more risky in the financial market. This increased riskiness causes these bonds to typically sell for 1/2% above similar G.O. issues. In addition, reserve funds of approximately 25% of the annual principal and interest are required in order to provide

the bond buyers an additional level of protection. Also, other reserve funds for equipment replacement and capital improvements are typically required. Revenue bonds do create a forced savings plan in that additional reserve accounts do contain monies which can be used once the revenue issue is paid off. However, revenue bonds, because of the additional required reserve, do demand higher sewer rates than a comparable G.O. issue. Finally, unlike general obligation bonds, no election is required for revenue bonds.

### SPECIAL ASSESSMENT BONDS

Special Assessment Bonds are paid through the collection of periodic payments from benefitted property owners. Special assessment bonding has been utilized to finance the construction of public utilities and streets in the past. The method simply assigns a proportional share of the cost against the benefitted properties, usually according to a front foot or area formula. The bond issue is sold by the municipality and it is paid off when the benefitted property owners pay their assessment on an annual basis. The assessment against a property resides with the property title in the form of a lien (financial obligation) against the property. The rates for special assessment bonds are usually somewhere between the revenue bond issue and general obligation bonds.

### GENERAL OBLIGATION BONDS/ABATED WITH UTILITY REVENUES

This form of bonds combines the attributes of general obligation and revenue bond financing. A general obligation bond is financed by pledging a portion of the tax base. Utility rates are increased to pay for the new debt. Surplus revenues are utilized to pay the principal and interest on the general obligation bond and the pledged increase in property taxes is abated through the use of this source of funds. Because this type of financing pledges part of the taxation base of the city, the reserve funds that are required under revenue bonds are not needed. On the surface to the bond holder, this type of financing appears to be a straightforward general obligation bond.

### STATE REVOLVING FUND (SRF)

This fund is operated by the Iowa Department of Natural Resources and the Iowa Finance Authority and provides low interest loans for financing improvements to wastewater treatment facilities. The loan takes the form of a revenue bond or a general obligation bond issued by the City and is purchased by the Iowa Finance Authority. The interest rate is dependent upon the rate at which the State can sell bonds. The annual rate has been running at 1.75%. For a sewer revenue issue the coverage requirement is 10%. This means that the net revenues of the system cannot be less than 110% of the operating, maintenance and debt service expenses of the system. This compares to a typical coverage of 25% for a conventional sewer revenue bond issue. There is a 0.5% loan initiation fee and a 0.25% annual loan servicing fee. In addition, the City must have an approved user charge system to ensure "fairness" and to ensure that adequate revenues are generated. There are also some additional requirements with respect to the construction contract documents.

## CHAPTER 7 - SCHEDULE

The report evaluated the City of Lone Tree’s Wastewater Treatment Facility. The report recommends the construction of a mechanical treatment facility consisting of flow equalization; preliminary treatment with screening and grit removal;.Aero-Mod SEQUOX activated sludge treatment including final clarifiers and aerobic digestion; ultraviolet disinfection; and sludge storage. Based on the recommended improvements, a projected schedule for project completion is as follows:

**Table 7 - 1: Proposed Project Schedule**

	Proposed Schedule	Compliance Schedule
Submit Facility Plan Report to IDNR	March 1, 2018	August 1, 2016
Receive IDNR Facility Plan Approval	April, 2018	
Plans and Specifications 60% Complete	October 2018	
Plans and Specifications 90% Complete	December 2018	
Construction Permit Application Submitted with Final Plans and Specifications	January 2019	May 1, 2018
Project Bids	February 2019	
Begin Construction	March 2019	
Construction Completion	March 2020	August 1, 2019
Ammonia and <i>E.Coli</i> Compliance Achieved	April 2020	September 1, 2019

It should be noted that the proposed schedule is behind the compliance schedule in the NPDES permit. Additional time was used during the facility planning stage due to concerns about financing and selection of the mechanical treatment alternative as well as review and response times from state agencies.



## CHAPTER 8 - SUMMARY AND RECOMMENDATIONS

The report evaluated the City of Lone Tree’s Wastewater Treatment Facility. The report recommends the construction of a mechanical treatment facility consisting of flow equalization; preliminary treatment with screening and grit removal;.Aero-Mod SEQUOX activated sludge treatment including final clarifiers and aerobic digestion; ultraviolet disinfection; and sludge storage. A summary of the findings of the study are:

1. The City of Lone Tree uses an aerated lagoon for wastewater treatment. The facility was converted to an aerated lagoon in 1999. The facility has received a new permit from the Iowa Department of Natural Resources. The aerated lagoon cannot meet the new effluent requirements.
2. The currently permitted flows listed on the Iowa Department of Natural Resources operating permit are shown below.

	<u>DESIGN FLOWS</u>
ADW, mgd	0.1150
AWW, mgd	0.4170
MWW, mgd	1.6000

3. Lone Tree has experienced a growing population trend over the last 20 years. Lone Tree is anticipating continued population growth over the next 20 years. The population of Lone Tree is shown in the table below.

<u>YEAR</u>	<u>POPULATION</u>
1990	979
2000	1,151
2010	1,300
2020	1,480*
2030	1,660*
2038	1,800*

\*Estimated

4. Due to projected population growth, the flows and loadings to the wastewater treatment facility are expected to increase from the current operating levels. The flows and loadings have been projected for the facility based on a 20-year design life as required by the Iowa Department of Natural Resources. These values reflect the actual historical data as discussed in this report. The design flows and loadings for the entire facility are shown in the table on the following page.

	<u>2015</u>	<u>2038</u>
<b>Population</b>	<b>1,390</b>	<b>1,800</b>
<b>Flow, MGD</b>		
ADW	0.1350	0.1760
AWW 180	0.3610	0.4020
AWW 30	0.7400	0.8220
MWW	2.0600	2.2240
PHWW	5.7000	5.7000
<b>Organic Loadings lbs./day</b>		
BOD	290	360
TSS	390	472
TKN	63	78

5. New water quality standards have been given to the City of Lone Tree by the Iowa Department of Natural Resources, which lower the effluent ammonia limits and require disinfection of the effluent prior to discharge. The current facility will be unable to meet the proposed effluent standards.

6. The following treatment alternatives were considered for Lone Tree:

<u>Alternatives</u>	<u>Cost</u>
1) Existing Aerated Lagoon	n/a
2) Land Application	n/a
3) Mechanical Treatment	
3A) Sequencing Batch Reactor	\$5,058,000
3B) SEQUOX	\$5,720,000
4) Enhanced Aerated Lagoon Treatment	
4A) OPTAER/SAGR	\$3,986,000
4B) LemTec	\$5,027,000
4C) IDEAL	\$4,484,000

7. Through discussion with the City, it was decided that a mechanical plant offered the best ability for long-term flexibility and ability to accommodate possible future nutrient discharge limits with regard to total nitrogen and phosphorus. The City selected Aero-Mod SEQUOX as the mechanical treatment system that would best suit its needs with regard to operation and maintenance of a mechanical facility.

8. The Aero-Mod treatment alternative included provisions for flow equalization, preliminary treatment, ultraviolet disinfection and sludge storage. The Aero-Mod SEQUOX alternative is estimated to cost \$5,720,000 including design and construction of the facility.

9. Because the alternative includes utilization of the existing aerated cells for equalization, removal of all biosolids from the existing lagoon should be considered. A cost for biosolids removal has been included in the cost of constructing the Aero-Mod SEQUOX mechanical treatment facility.
  
10. There are many financing options available to for the City of Lone Tree. Wastewater improvement projects are typically financed through one of the following methods or a combination of the following methods: general obligation bonds, revenue bonds, special assessment bonds, general obligation bonds abated through revenues, State Revolving Fund (SRF) and utility fund reserves.
  
11. A proposed schedule of improvements was provided. The schedule is shown below.

	Proposed Schedule	Compliance Schedule
Submit Facility Plan Report to IDNR	March 1, 2018	August 1, 2016
Receive IDNR Facility Plan Approval	April, 2018	
Plans and Specifications 60% Complete	October 2018	
Plans and Specifications 90% Complete	December 2018	
Construction Permit Application Submitted with Final Plans and Specifications	January 2019	May 1, 2018
Project Bids	February 2019	
Begin Construction	March 2019	
Construction Completion	March 2020	August 1, 2019
Ammonia and <i>E.Coli</i> Compliance Achieved	April 2020	September 1, 2019

## APPENDIX A - NPDES PERMIT

**IOWA DEPARTMENT OF NATURAL RESOURCES**  
**National Pollutant Discharge Elimination System (NPDES) Permit**

**OWNER NAME & ADDRESS**

CITY OF LONE TREE  
PO BOX 337  
123 N DEVOE STREET  
LONE TREE, IA 52755-0337

**FACILITY NAME & ADDRESS**

LONE TREE CITY OF STP (SOUTH)  
5099 620TH STREET SE  
LONE TREE, IA 52755

Section 16, T77N, R05W  
Johnson County

**IOWA NPDES PERMIT NUMBER:** 5240001

**DATE OF ISSUANCE:** 05/01/2015

**DATE OF EXPIRATION:** 04/30/2020

**YOU ARE REQUIRED TO FILE FOR**

**RENEWAL OF THIS PERMIT BY:** 11/02/2019

**EPA NUMBER:** IA0060330

This permit is issued pursuant to the authority of section 402(b) of the Clean Water Act (33 U.S.C 1342(b)), Iowa Code section 455B.174, and rule 567-64.3, Iowa Administrative Code. You are authorized to operate the disposal system and to discharge the pollutants specified in this permit in accordance with the effluent limitations, monitoring requirements and other terms set forth in this permit.

You may appeal any condition of this permit by filing a written notice of appeal and request for administrative hearing with the director of this department within 30 days of your receipt of this permit.

Any existing unexpired Iowa operation permit or Iowa NPDES permit previously issued by the department for the facility identified above is revoked by the issuance of this permit. This provision does not apply to any authorization to discharge under the terms and conditions of a general permit issued by the department or to any permit issued exclusively for the discharge of stormwater.

FOR THE DEPARTMENT OF NATURAL RESOURCES

By \_\_\_\_\_

Eric Wiklund  
NPDES Section  
ENVIRONMENTAL SERVICES DIVISION

**Facility Name:** LONE TREE CITY OF STP (SOUTH)

**Permit Number:** 5240001

**Outfall No.:** 001 DISCHARGE FROM A THREE CELL AERATED WASTEWATER TREATMENT FACILITY.

**Receiving Stream:** PRAIRIE CREEK

**Route of Flow:** PRAIRIE CREEK

Class A2 waters are secondary contact recreational use waters in which recreational or other uses may result in contact with the water that is either incidental or accidental. During the recreational use, the probability of ingesting appreciable quantities of water is minimal. Class A2 uses include fishing, commercial and recreational boating, any limited contact incidental to shoreline activities and activities in which users do not swim or float in the water body while on a boating activity.

Waters designated Class B(WW2) are those in which flow or other physical characteristics are capable of supporting a resident aquatic community that includes a variety of native nongame fish and invertebrate species. The flow and other physical characteristics limit the maintenance of warm water game fish populations. These waters generally consist of small perennially flowing streams.

**Bypasses from any portion of a treatment facility or from a sanitary sewer collection system designed to carry only sewage are prohibited.**

Facility Name: LONE TREE CITY OF STP (SOUTH)

Permit Number: 5240001

**Effluent Limitations:**

You are prohibited from discharging pollutants except in compliance with the following effluent limitations:

**001 DISCHARGE FROM A THREE CELL AERATED WASTEWATER TREATMENT FACILITY.**

<i>Outfall: 001 Effective Dates: 05/01/2015 to 04/30/2020</i>			
<u>Parameter</u>	<u>Season</u>	<u>Limit Type</u>	<u>Limits</u>
<b>CBOD5</b>			<b>85% Removal Required</b>
	Yearly	7 Day Average	40 MG/L 139 LBS/DAY
	Yearly	30 Day Average	25 MG/L 88 LBS/DAY
<b>TOTAL SUSPENDED SOLIDS</b>			
	Yearly	7 Day Average	120 MG/L 417 LBS/DAY
	Yearly	30 Day Average	80 MG/L 278 LBS/DAY
<b>DISSOLVED OXYGEN (MINIMUM)</b>			
	Yearly	Minimum	5.0 MG/L
<b>PH</b>			
	Yearly	Daily Maximum	9.0 STD UNITS
	Yearly	Minimum	6.5 STD UNITS

<i>Outfall: 001 Effective Dates: 05/01/2015 to 08/31/2019</i>			
<u>Parameter</u>	<u>Season</u>	<u>Limit Type</u>	<u>Limits</u>
<b>AMMONIA NITROGEN (N)</b>			
	JUL	30 Day Average	8.7 MG/L 30 LBS/DAY
	JUL	Daily Maximum	13 MG/L 46 LBS/DAY
	AUG	30 Day Average	8.7 MG/L 30 LBS/DAY
	AUG	Daily Maximum	13 MG/L 46 LBS/DAY

Facility Name: LONE TREE CITY OF STP (SOUTH)

Permit Number: 5240001

<i>Outfall: 001 Effective Dates: 09/01/2019 to 04/30/2020</i>			
<u>Parameter</u>	<u>Season</u>	<u>Limit Type</u>	<u>Limits</u>
<b>AMMONIA NITROGEN (N)</b>			
	JAN	30 Day Average	5.2 MG/L 18.0 LBS/DAY
	JAN	Daily Maximum	19.9 MG/L 69.2 LBS/DAY
	FEB	30 Day Average	5.8 MG/L 20.2 LBS/DAY
	FEB	Daily Maximum	8.4 MG/L 29.2 LBS/DAY
	MAR	30 Day Average	3.9 MG/L 13.5 LBS/DAY
	MAR	Daily Maximum	3.9 MG/L 13.5 LBS/DAY
	APR	30 Day Average	2.1 MG/L 7.3 LBS/DAY
	APR	Daily Maximum	4.7 MG/L 16.4 LBS/DAY
	MAY	30 Day Average	1.8 MG/L 6.4 LBS/DAY
	MAY	Daily Maximum	3.2 MG/L 11.1 LBS/DAY
	JUN	30 Day Average	1.3 MG/L 4.7 LBS/DAY
	JUN	Daily Maximum	3.2 MG/L 11.1 LBS/DAY
	JUL	30 Day Average	1.1 MG/L 3.8 LBS/DAY
	JUL	Daily Maximum	3.2 MG/L 11.1 LBS/DAY
	AUG	30 Day Average	1.0 MG/L 3.4 LBS/DAY



Facility Name: LONE TREE CITY OF STP (SOUTH)

Permit Number: 5240001

<i>Outfall: 001 Effective Dates: 09/01/2019 to 04/30/2020</i>			
<u>Parameter</u>	<u>Season</u>	<u>Limit Type</u>	<u>Limits</u>
<b>AMMONIA NITROGEN (N)</b>			
	AUG	Daily Maximum	2.7 MG/L 9.2 LBS/DAY
	SEP	30 Day Average	1.5 MG/L 5.2 LBS/DAY
	SEP	Daily Maximum	2.7 MG/L 9.2 LBS/DAY
	OCT	30 Day Average	2.7 MG/L 9.2 LBS/DAY
	OCT	Daily Maximum	2.7 MG/L 9.2 LBS/DAY
	NOV	30 Day Average	2.7 MG/L 9.2 LBS/DAY
	NOV	Daily Maximum	2.7 MG/L 9.2 LBS/DAY
	DEC	30 Day Average	3.9 MG/L 13.5 LBS/DAY
	DEC	Daily Maximum	3.9 MG/L 13.5 LBS/DAY
<b>E. COLI</b>			
	MAR	Geometric Mean	630 #/100 ML
	APR	Geometric Mean	630 #/100 ML
	MAY	Geometric Mean	630 #/100 ML
	JUN	Geometric Mean	630 #/100 ML
	JUL	Geometric Mean	630 #/100 ML
	AUG	Geometric Mean	630 #/100 ML
	SEP	Geometric Mean	630 #/100 ML
	OCT	Geometric Mean	630 #/100 ML
	NOV	Geometric Mean	630 #/100 ML

**Facility Name:** LONE TREE CITY OF STP (SOUTH)

**Permit Number:** 5240001

### **Monitoring and Reporting Requirements**

- (a) Samples and measurements taken shall be representative of the volume and nature of the monitored wastewater.
- (b) Analytical and sampling methods specified in 40 CFR Part 136 or other methods approved in writing by the department shall be utilized. Samples collected for operational testing need not be analyzed by approved analytical methods; however, commonly accepted test methods should be used.
- (c) You are required to report all data including calculated results needed to determine compliance with the limitations contained in this permit. The results of any monitoring not specified in this permit performed at the compliance monitoring point and analyzed according to 40 CFR Part 136 shall be included in the calculation and reporting of any data submitted in accordance with this permit. This includes daily maximums and minimums and 30-day and 7-day averages for all parameters that have concentration (mg/l) and mass (lbs/day) limits. In addition, flow data shall be reported in million gallons per day (MGD).
- (d) Results of all monitoring shall be recorded on forms provided by, or approved by, the department, and shall be submitted to the appropriate regional field office of the department by the fifteenth day following the close of the reporting period. Your reporting period is on a MONTHLY basis, ending on the last day of each reporting period.
- (e) Any records of monitoring activities and results shall include for all samples: the date, exact place and time of the sampling; the dates the analyses were performed; who performed the analyses; the analytical techniques or methods used; and the results of such analyses.
- (f) Chapter 63 of the Iowa Administrative Code contains further explanation of these monitoring requirements.

**Facility Name:** LONE TREE CITY OF STP (SOUTH)

**Permit Number:** 5240001

<b>Outfall</b>	<b>Wastewater Parameter</b>	<b>Sample Frequency</b>	<b>Sample Type</b>	<b>Monitoring Location</b>
The following monitoring requirements shall be in effect from 05/01/2015 to 04/30/2020				
001	FLOW	7/WEEK OR DAILY	24 HOUR TOTAL	RAW WASTE OR FINAL EFFLUENT(FLOW)
001	BIOCHEMICAL OXYGEN DEMAND (BOD5)	1 TIME PER WEEK	24 HOUR COMPOSITE	RAW WASTE
001	PH	1 TIME PER WEEK	GRAB	RAW WASTE
001	TEMPERATURE	1 TIME PER WEEK	GRAB	RAW WASTE
001	TOTAL SUSPENDED SOLIDS	1 EVERY 2 WEEKS	24 HOUR COMPOSITE	RAW WASTE
001	CBOD5	1 TIME PER WEEK	GRAB	EFFLUENT PRIOR TO DISINFECTION
001	TOTAL SUSPENDED SOLIDS	1 EVERY 2 WEEKS	GRAB	EFFLUENT PRIOR TO DISINFECTION
001	AMMONIA NITROGEN (N)	1 TIME PER WEEK	GRAB	EFFLUENT AFTER DISINFECTION
001	DISSOLVED OXYGEN (MINIMUM)	1 TIME PER WEEK	GRAB	EFFLUENT AFTER DISINFECTION
001	PH	1 TIME PER WEEK	GRAB	EFFLUENT AFTER DISINFECTION
001	TEMPERATURE	1 TIME PER WEEK	GRAB	EFFLUENT AFTER DISINFECTION
001	DISSOLVED OXYGEN	1 TIME PER WEEK	GRAB	AERATED CELL 2 CONTENTS
001	DISSOLVED OXYGEN	1 TIME PER WEEK	GRAB	AERATED CELL 1 CONTENTS
The following monitoring requirements shall be in effect from 09/01/2019 to 04/30/2020				
001	E. COLI	GEO. MEAN 1/3 MONTHS	GRAB	EFFLUENT AFTER DISINFECTION

**Facility Name:** LONE TREE CITY OF STP (SOUTH)

**Permit Number:** 5240001

### **Special Monitoring Requirements**

**Outfall # Description**

**001 E. COLI**

The limit for E. coli of 630 org/100 ml specified on page 6 of this permit for Outfall 001 is a geometric mean. The disinfection season is established in the Iowa Administrative Code, Subparagraph 567 IAC 61.3(3)“a”(1), and is in effect from March 15 to November 15. Any disinfection system (chlorine, UV light, etc.) shall be operated to comply with the limit during the entire disinfection season whenever wastewater is being discharged from Outfall 001.

The facility must collect and analyze a minimum of five samples in one calendar month during each 3-month period from March 15 to November 15. The 3-month periods are March – May, June – August, and September – November. The collection of five samples in each 3-month period will result in a minimum of 15 samples being collected during a calendar year. For example, for the first 3-month period, the operator may choose April as the calendar month to collect the 5 individual E. coli samples to determine compliance with the limits. The operator may also choose the months of March or May as well, as long as each of the 5 samples is collected during a single calendar month. The same principle applies to the other two 3-month periods during the disinfection season. The following requirements apply to the individual samples collected in one calendar month:

Samples must be spaced over one calendar month.

No more than one sample can be collected on any one day.

There must be a minimum of two days between each sample.

No more than two samples may be collected in a period of seven consecutive days.

If the effluent has been disinfected using chlorine, ultraviolet light (UV), or any other process intended to disrupt the biological integrity of the E. coli, the samples shall be analyzed using the Most Probable Number method found in Standard Method 9223B (Colilert® or Colilert-18® made by IDEXX Laboratories, Inc.). If the effluent has not been disinfected the samples may be analyzed using either the MPN method above or EPA Method 1603: Escherichia coli (E. coli) in water by membrane filtration using modified membrane-thermotolerant E. coli agar (modified mTEC) or mColiBlue-24® made by the Hach Company.

The geometric mean must be calculated using all valid sample results collected during a month. The geometric mean formula is as follows: Geometric Mean = (Sample one \* Sample two \* Sample three \* Sample four \* Sample five...Sample N)<sup>(1/N)</sup>, which is the Nth root of the result of the multiplication of all of the sample results where N = the number of samples. If a sample result is a less than value, the value reported by the lab without the less than sign should be used in the geometric mean calculation.

The geometric mean can be calculated in one of the following ways:

Use a scientific calculator that can calculate the powers of numbers.

Enter the samples in Microsoft Excel and use the function “GEOMEAN” to perform the calculation.

Use the geometric mean calculator on the Iowa DNR webpage at:

<http://www.iowadnr.gov/InsideDNR/RegulatoryWater/NPDES/WastewaterPermitting/NPDESOperatorInformation/BacteriaSampling.aspx>.

#### **AMMONIA NITROGEN (N)**

Ammonia shall be sampled and analyzed using an EPA approved method specified in 40 CFR 136 or using the Timberline Method Ammonia-001 alternative test procedure.

**Facility Name:** LONE TREE CITY OF STP (SOUTH)

**Permit Number:** 5240001

### **ADDITIONAL OPERATING, MONITORING AND REPORTING REQUIREMENTS**

1. In addition to the monitoring requirements specified elsewhere in this permit, within 60 days of the issuance of this permit you shall sample, analyze and submit the results of at least one analysis representative of the actual discharge for dissolved oxygen (DO), nitrate + nitrite nitrogen, Total Kjeldahl Nitrogen (TKN), oil and grease and phosphorus. The samples you collect and analyze must be grab samples of the final effluent collected on a day when the plant is operating normally. The results of these analyses will be evaluated and the department will reopen this permit if it is determined that there is a reasonable potential for the discharge to cause or contribute to a violation of a water quality standard for any parameter. The lab report with the analysis results must be mailed to the address shown below within thirty (30) days of sample collection.

Eric Wiklund  
NPDES Section  
Iowa Department of Natural Resources  
502 East 9<sup>th</sup> Street  
Des Moines, Iowa 50319

**Facility Name:** LONE TREE CITY OF STP (SOUTH)

**Permit Number:** 5240001

### **Design Capacity**

#### **Design: 1**

The design capacity for the treatment works is specified in Construction Permit Number 00-030-S, issued Thursday, October 28, 1999.

The treatment plant is designed to treat:

- \* An average dry weather (ADW) flow of 0.1150 Million Gallons Per Day (MGD).
- \* An average wet weather (AWW) flow of 0.4170 Million Gallons Per Day (MGD).
- \* A maximum wet weather (MWW) flow of 1.6000 Million Gallons Per Day (MGD).
- \* A design 5-day biochemical oxygen demand (BOD5) load of 228 lbs/day.

Operator Certification Type/Grade: WL/I

Wastes in such volumes or quantities as to exceed the design capacity of the treatment works or reduce the effluent quality below that specified in the operation permit of the treatment works are considered to be a waste which interferes with the operation or performance of the treatment works and are prohibited by rule IAC 567-62.1(7).

**Facility Name:** LONE TREE CITY OF STP (SOUTH)

**Permit Number:** 5240001

### **SEWAGE SLUDGE HANDLING AND DISPOSAL REQUIREMENTS**

"Sewage sludge" is solid, semisolid, or liquid residue generated during the treatment of domestic sewage in a treatment works. Sewage sludge does not include the grit and screenings generated during preliminary treatment.

1. The permittee shall comply with all existing Federal and State laws and regulations that apply to the use and disposal of sewage sludge and with technical standards developed pursuant to Section 405(d) of the Clean Water Act when such standards are promulgated. If an applicable numerical limit or management practice for pollutants in sewage sludge is promulgated after issuance of this permit that is more stringent than a sludge pollutant limit or management practice specified in existing Federal or State laws or regulations, this permit shall be modified, or revoked and reissued, to conform to the regulations promulgated under Section 405(d) of the Clean Water Act. The permittee shall comply with the limitation no later than the compliance deadline specified in the applicable regulations.
2. The permittee shall provide written notice to the Department of Natural Resources prior to any planned changes in sludge disposal practices.
3. Land application of sewage sludge shall be conducted in accordance with criteria established in rule IAC 567--67.1 through 67.11 (455B).

**Facility Name:** LONE TREE CITY OF STP (SOUTH)

**Permit Number:** 5240001

### **MAJOR CONTRIBUTING INDUSTRIES LIMITATIONS, MONITORING AND REPORTING REQUIREMENTS**

**1.** You are required to notify the department, in writing, of any of the following:

(a) 180 days prior to the introduction of pollutants to your facility from a significant industrial user. A significant industrial user means an industrial user of a treatment works that:

(1) Discharges an average of 25,000 gallons per day or more of process wastewater excluding sanitary, noncontact cooling and boiler blowdown wastewater;  
(2) Contributes a process waste stream which makes up five percent or more of the average dry weather hydraulic or organic capacity of the publicly-owned treatment works;

(3) Is subject to Categorical Pretreatment Standards under 40 CFR 403.6 and 40 CFR Chapter I, Subchapter N; or

(4) Is designated by the department as a significant industrial user on the basis that the contributing industry, either singly or in combination with other contributing industries, has a reasonable potential for adversely affecting the operation of or effluent quality from the publicly-owned treatment works or for violating any pretreatment standards or requirements.

(b) 60 days prior to a proposed expansion, production increase or process modification that may result in the discharge of a new pollutant or a discharge in excess of limitations stated in the existing treatment agreement.

(c) 10 days prior to any commitment by you to accept waste from any new significant industrial user. Your written notification must include a new or revised treatment agreement in accordance with rule 64.3(5)(455B).

**2.** You shall require all users of your facility to comply with Sections 204(b), 307 and 308 of the Clean Water Act.

Section 204(b) requires that all users of the treatment works constructed with funds provided under Sections 201(g) or 601 of the Act to pay their proportionate share of the costs of operation, maintenance and replacement of the treatment works.

Section 307 of the Act requires users to comply with pretreatment standards promulgated by EPA for pollutants that would cause interference with the treatment process or would pass through the treatment works.

Section 308 of the Act requires users to allow access at reasonable times to state and EPA inspectors for the purpose of sampling the discharge and reviewing and copying records.

**3.** You shall limit and monitor pollutants for each significant industrial user as required elsewhere in this permit, and submit sample results to the department monthly. Your report shall be submitted by the fifteenth day of the following month.

Revised: June 16, 2009 CAC



**Facility Name:** LONE TREE CITY OF STP (SOUTH)

**Permit Number:** 5240001

### **Ammonia Nitrogen and *E. coli* Compliance Schedule**

1. The City of Lone Tree shall make necessary improvements to meet ammonia nitrogen and *E. coli* limits according to the following schedule:
  - Complete a Self-Assessment Matrix and submit a Work Record Request form to DNR's Wastewater Engineering Section by 8/1/2015. The forms and instructions are available on the DNR website at <http://www.iowadnr.gov/InsideDNR/RegulatoryWater/WastewaterConstruction.aspx>. Questions on the forms should be directed to either Terry Kirschenman at 515/725-8422 or Emy Liu at 515-725-8421.
  - Submit progress report by 5/1/2016.
  - Submit a Facility Plan by 8/1/2016. The Facility Plan shall be in accordance with Chapter 11.2 of the Iowa Wastewater Facilities Design Standards adopted April 25, 1979.
  - Submit progress report by 5/1/2017.
  - Submit final plans and specifications by 5/1/2018.
  - Award contract for construction of wastewater treatment improvements by 10/1/2018.
  - Submit progress report by 1/1/2019.
  - Complete construction of wastewater treatment improvements by 8/1/2019.
  - Achieve compliance with all final ammonia nitrogen and *E. coli* limits by 9/1/2019.

Within fourteen (14) days following all dates of compliance, the permittee shall provide written notice of compliance with the scheduled event. All written notices and progress reports shall be sent to the following addresses:

Iowa Department of Natural Resources  
Environmental Services Division  
Regional Office #6  
1023 West Madison  
Washington, IA 52353

## STANDARD CONDITIONS

### 1. ADMINISTRATIVE RULES

Rules of this Department that govern the operation of your facility in connection with this permit are published in Part 567 of the Iowa Administrative Code (IAC) in Chapters 60-65, 67, and 121. Reference to the term “rule” in this permit means the designated provision of Part 567 of the IAC. Reference to the term “CFR” means the Code of Federal Regulations.

### 2. DEFINITIONS

- (a) 7 day average means the sum of the total daily discharges by mass, volume, or concentration during a 7 consecutive day period, divided by the total number of days during the period that measurements were made. Four 7 consecutive day periods shall be used each month to calculate the 7-day average. The first 7-day period shall begin with the first day of the month.
- (b) 30 day average means the sum of the total daily discharges by mass, volume, or concentration during a calendar month, divided by the total number of days during the month that measurements were made.
- (c) Daily maximum means the total discharge by mass, volume, or concentration during a twenty-four hour period.

### 3. DUTY TO COMPLY

You must comply with all conditions of this permit. Any permit noncompliance constitutes a violation of the Clean Water Act and is grounds for enforcement action; permit termination, revocation and reissuance, or modification; or denial of a permit renewal application. Issuance of this permit does not relieve you of the responsibility to comply with all local, state and federal laws, ordinances, regulations or other legal requirements applying to the operation of your facility. *{See 40 CFR 122.41(a) and 567 IAC 64.7(4)“e”}*

### 4. DUTY TO PROVIDE INFORMATION

You must furnish to the Director, within a reasonable time, any information the Director may request to determine compliance with this permit or determine whether cause exists for modifying, revoking and reissuing, or terminating this permit, in accordance with 567 IAC 64.3(11)(c). You must also furnish to the Director, upon request, copies of any records required to be kept by this permit.

### 5. NEED TO HALT OR REDUCE ACTIVITY

It shall not be a defense for a permittee in an enforcement action that it would have been necessary to halt or reduce the permitted activity in order to maintain compliance with the conditions of this permit. *{See 40 CFR 122.41(c) and 567 IAC 64.7(7)“j”}*

### 6. DUTY TO MITIGATE

You shall take all reasonable steps to minimize or prevent any discharge in violation of this permit which has a reasonable likelihood of adversely affecting human health or the environment. *{See 40 CFR 122.41(d) and 567 IAC 64.7(7)“i”}*

### 7. PROPERTY RIGHTS

This permit does not convey any property rights of any sort or any exclusive privilege. *{See 567 IAC 64.4(3)“b”}*

### 8. TRANSFER OF TITLE OR OWNER ADDRESS CHANGE

If title to your facility, or any part of it, is transferred the new owner shall be subject to this permit. You are required to notify the new owner of the requirements of this permit in writing prior to any transfer of title. The Director shall be notified in writing within 30 days of the transfer. No transfer of the authorization to discharge from the facility represented by the permit shall take place prior to notifying the department of the transfer of title. Whenever the address of the owner is changed, the department shall be notified in writing within 30 days of the address change. Electronic notification is not sufficient; all title transfers or address changes must be reported to the department by mail. *{See 567 IAC 64.14}*

### 9. PROPER OPERATION AND MAINTENANCE

All facilities and control systems shall be operated as efficiently as possible and maintained in good working order. A sufficient number of staff, adequately trained and knowledgeable in the operation of your facility shall be retained at all times and adequate laboratory controls and appropriate quality assurance procedures shall be provided to maintain compliance with the conditions of this permit. *{See 40 CFR 122.41(e) and 567 IAC 64.7(7)“f”}*

### 10. PERMIT MODIFICATION, SUSPENSION OR REVOCATION

- (a) This permit may be modified, suspended, or revoked and reissued for cause including but not limited to those specified in 567 IAC 64.3(11).
- (b) This permit may be modified due to conditions or information on which this permit is based, including any new standard the department may adopt that would change the required effluent limits. *{See 567 IAC 64.3(11)}*
- (c) If a toxic pollutant is present in your discharge and more stringent standards for toxic pollutants are established under Section 307(a) of the Clean Water Act, this permit will be modified in accordance with the new standards. *{See 40 CFR 122.62(a)(6) and 567 IAC 64.7(7)“g”}*

The filing of a request for a permit modification, revocation or suspension, or a notification of planned changes or anticipated noncompliance does not stay any permit condition.

### 11. DUTY TO REAPPLY AND PERMIT CONTINUATION

If you wish to continue to discharge after the expiration date of this permit, you must file a complete application for reissuance at least 180 days prior to the expiration date of this permit. If a timely and sufficient application is submitted, this permit will remain in effect until the Department makes a final determination on the permit application. *{See 567 IAC 64.8(1) and Iowa Code 17A.18}*

### 12. SIGNATORY REQUIREMENTS

Applications, reports or other information submitted to the Department in connection with this permit must be signed and certified as required by 567 IAC 64.3(8).

## STANDARD CONDITIONS

### 13. TWENTY-FOUR HOUR REPORTING

You shall report any noncompliance that may endanger human health or the environment, including, but not limited to, violations of maximum daily limits for any toxic pollutant (listed as toxic under 307(a)(1) of the Clean Water Act) or hazardous substance (as designated in 40 CFR Part 116 pursuant to 311 of the Clean Water Act). Information shall be provided orally within 24 hours from the time you become aware of the circumstances. A written submission that includes a description of noncompliance and its cause; the period of noncompliance including exact dates and times, whether the noncompliance has been corrected or the anticipated time it is expected to continue; and the steps taken or planned to reduce, eliminate, and prevent a reoccurrence of the noncompliance must be provided within 5 days of the occurrence. *{See 567 IAC 63.12}*

### 14. OTHER NONCOMPLIANCE

You shall report all instances of noncompliance not reported under Condition #13 at the time monitoring reports are submitted. You shall give advance notice to the appropriate regional field office of the department of any planned activity which may result in noncompliance with permit requirements. *{See 567 IAC 63.14}*

### 15. PLANNED CHANGES

The permittee shall give notice to the appropriate regional field office of the department 30 days prior to any planned physical alterations or additions to the permitted facility. Notice is required only when:

- (a) Notice has not been given to any other section of the department: (Note: Facility expansions, production increases, or process modifications which may result in new or increased discharges of pollutants must be reported to the Director in advance. If such discharges will exceed effluent limitations, your report must include an application for a new permit. If any modification of, addition to, or construction of a disposal system is to be made, you must first obtain a written permit from this Department.) *{See 567 IAC 64.7(7)“a” and 64.2}*
- (b) The alteration or addition to a permitted facility may meet one of the criteria for determining whether a facility is a new source as defined in 567 IAC 60.2;
- (c) The alteration or addition results in a significant change in the permittee's sludge use or disposal practices; or
- (d) The alteration or addition could significantly change the nature or increase the quantity of pollutants discharged. This notification applies to pollutants that are not subject to effluent limitations in the permit. *{See 567 IAC 63.13 and 63.14}*

### 16. EFFECT OF A PERMIT

Compliance with a permit during its term constitutes compliance, for purposes of enforcement, with Sections 301, 302, 306, 307, 318, 403 and 405(a)-(b) of the Clean Water Act, and equivalent limitations and standards set out in 567 IAC Chapters 61 and 62. *{See 567 IAC 64.4(3)“a”}*

### 17. MONITORING AND RECORDS OF OPERATION

- (a) Maintenance of records. You shall retain for a minimum of three years all paper and electronic records of monitoring activities and results including all original strip chart recordings for continuous monitoring instrumentation and calibration and maintenance records. *{See 567 IAC 63.2(3)}*
- (b) Any person who falsifies, tampers with, or knowingly renders inaccurate any monitoring device or method required to be maintained under this permit shall, upon conviction, be punished by a fine of not more than \$10,000 or by imprisonment for not more than two years, or both. *{See 40 CFR 122.41(j)(5)}*

### 18. USE OF CERTIFIED LABORATORIES

Effective October 1, 1996, analyses of wastewater, groundwater or sewage sludge that are required to be submitted to the department as a result of this permit must be performed by a laboratory certified by the State of Iowa. Routine, on-site monitoring for pH, temperature, dissolved oxygen, total residual chlorine and other pollutants that must be analyzed immediately upon sample collection, settleable solids, physical measurements, and operational monitoring tests specified in 567 IAC 63.3(4) are excluded from this requirement.

### 19. INSPECTION OF PREMISES, RECORDS, EQUIPMENT, METHODS AND DISCHARGES

You are required to permit authorized personnel to:

- (a) Enter upon the premises where a regulated facility or activity is located or conducted or where records are kept under conditions of this permit.
- (b) Have access to and copy, at reasonable times, any records that must be kept under the conditions of this permit.
- (c) Inspect, at reasonable times, any facilities, equipment, practices or operations regulated or required under this permit.
- (d) Sample or monitor, at reasonable times, to assure compliance or as otherwise authorized by the Clean Water Act.

### 20. FAILURE TO SUBMIT FEES

This permit may be revoked, in whole or in part, if the appropriate permit fees are not submitted within thirty (30) days of the date of notification that such fees are due. *{See 567 IAC 64.16(1)}*

### 21. OTHER INFORMATION

Where you become aware that you failed to submit any relevant facts in a permit application, or submitted incorrect information in a permit application, you must promptly submit such facts or information. Where you become aware that you failed to submit any relevant facts in the submission of in any report to the director, including records of operation, you shall promptly submit such facts or information. *{See 567 IAC 60.4(2)“a” and 567 IAC 63.7}*

## STANDARD CONDITIONS

### 22. NOTICE OF CHANGED CONDITIONS

You are required to notify the director of any changes in existing conditions or information on which this permit is based. This includes, but is not limited to, the following:

- (a) If your facility is a publicly owned treatment works (POTW) or otherwise may accept waste for treatment from an indirect discharger or industrial contributor (See 567 IAC 64.3(5) for further notice requirements).
- (b) If your facility is a POTW and there is any substantial change in the volume or character of pollutants being introduced to the POTW by a source introducing pollutants into the POTW at the time of issuance of the permit. *{See 40 CFR 122.42(b)}*
- (c) As soon as you know or have reason to believe that any activity has occurred or will occur which would result in the discharge of any toxic pollutant which is not limited in this permit. *{See 40 CFR 122.42(a)}*
- (d) If you have begun or will begin to use or manufacture as an intermediate or final product or byproduct any toxic pollutant which was not reported in the permit application.
- (e) No construction activity that will result in disturbance of one acre or more shall be initiated without first obtaining coverage under NPDES General Permit No. 2 for "Storm water discharge associated with construction activity".

### 23. BYPASSES

- (a) Definition. "Bypass" means the diversion of waste streams from any portion of a treatment facility or collection system. A bypass does not include internal operational waste stream diversions that are part of the design of the treatment facility, maintenance diversions where redundancy is provided, diversions of wastewater from one point in a collection system to another point in a collection system, or wastewater backups into buildings that are caused in the building lateral or private sewer line.
- (b) Prohibitions.
  - i. Bypasses from any portion of a treatment facility or from a sanitary sewer collection system designed to carry only sewage are prohibited.
  - ii. Bypass is prohibited and the department may not assess a civil penalty against a permittee for bypass if the permittee has complied with all of the following:
    - (1) Bypass was unavoidable to prevent loss of life, personal injury, or severe property damage; and
    - (2) There were no feasible alternatives to the bypass such as the use of auxiliary treatment facilities, retention of untreated wastes, or maintenance during normal periods of equipment downtime. This condition is not satisfied if adequate backup equipment should have been installed in the exercise of reasonable engineering judgment to prevent a bypass which occurred during normal periods of equipment downtime or preventive maintenance; and
    - (3) The permittee submitted notices as required by paragraph (d) of this section.

- (c) The Director may approve an anticipated bypass after considering its adverse effects if the Director determines that it will meet the three conditions listed above and a request for bypass has been submitted to the Department in accordance with 567 IAC 63.6(2).
- (d) Reporting bypasses. Bypasses shall be reported in accordance with 567 IAC 63.6.

### 24. UPSET PROVISION

- (a) Definition. "Upset" means an exceptional incident in which there is unintentional and temporary noncompliance with technology based permit effluent limitations because of factors beyond the reasonable control of the permittee. An upset does not include noncompliance to the extent caused by operational error, improperly designed treatment facilities, inadequate treatment facilities, lack of preventive maintenance, or careless or improper operation.
- (b) Effect of an upset. An upset constitutes an affirmative defense in an action brought for noncompliance with such technology based permit effluent limitations if the requirements of paragraph "c" of this condition are met. No determination made during administrative review of claims that noncompliance was caused by upset, and before an action for noncompliance, is final administrative action subject to judicial review.
- (c) Conditions necessary for demonstration of an upset. A permittee who wishes to establish the affirmative defense of upset shall demonstrate through properly signed operating logs or other relevant evidence that;
  - i. An upset occurred and that the permittee can identify the cause(s) of the upset;
  - ii. The permitted facility was at the time being properly operated;
  - iii. The permittee submitted notice of the upset to the Department in accordance with 567 IAC 63.6(3); and
  - iv. The permittee complied with any remedial measures required in accordance with 567 IAC 63.6(6)"b".
- (d) Burden of Proof. In any enforcement proceeding, the permittee seeking to establish the occurrence of an upset has the burden of proof.

### 25. SEVERABILITY

The provisions of this permit are severable and if any provision or application of any provision to any circumstance is found to be invalid by this department or a court of law, the application of such provision to other circumstances, and the remainder of this permit, shall not be affected by such finding.

APPENDIX B - UV DISINFECTION PROPOSALS

GLASCO, INC.  
TROJAN UV



# UV DISINFECTION PROJECT PROPOSAL

## NONCON S E R I E S

<b>Project Name:</b>	Lone Tree IOWA
<b>Proposal Number:</b>	ATD-07222016-19-1
<b>Date:</b>	July 22, 2016

<b>Prepared by:</b>	<b>Adam Donnellan</b> VP Sales
Email	<a href="mailto:adam@glascouv.com">adam@glascouv.com</a>
Mobile	201 785-4357

<b>Prepared for:</b>	<b>Matt Streeter</b>
Company	Engineered Equipment Solutions
Email	<a href="mailto:mstreeter@e-equipmentsolutions.com">mstreeter@e-equipmentsolutions.com</a>
Phone	<a href="tel:515-450-8803">515-450-8803</a>
Address	203 E. Main St.   P.O. Box 541   State Center, IA 50247

<b>Project Type:</b>	<b>Wastewater</b>
Type	Fluoropolymer Tube
Orientation	Horizontal – Stainless Steel reactor
System Name	NONCON-5000-3-6 x 8
Lamp Technology	Low pressure high output 155 W
Flow rate range	410,000 GPD in 2 banks



### BENEFITS OF NONCON 5000

- No quartz sleeves
- Flow through FEP tubes remain clean
- Energy efficient low pressure high output lamps
- Economical lamp costs

### TYPICAL EQUIPMENT

#### Standard

- 2 bank Stainless steel reactor with inlet and outlet
- Remote NEMA 4x ballast control center with run time and lamp status
- UV monitoring
- PLC monitoring (AB Micrologix)

#### By Others

- Inlet isolation gate
- Integration



## Design Information

### DESIGN OVERVIEW

Application	Wastewater
Peak flow	820,000 GPD
Per Bank	410,000 GPD
Minimum flow	0.0
Location	Indoors

Water Quality	
UV transmission %	55%
Influent counts	200,000 fc/100 ml
Water temp.	35-75° F
TSS	<30 mg/l
BOD	<30 mg/l
Discharge permit	<126 fc/100 ml
Design UV dosage	>30,000 uWs/cm <sup>2</sup> @ end of lamp life

Dimensions	
Channel length	220"
Channel width	30"
Channel height	24"
Connections	12" or other
Ballast Control Centers	40" x 30" x 12" NEMA 4x

### EQUIPMENT OVERVIEW

Model Name	NONCON-5000-3-6 x 8
System type	Horizontal
Configuration	Reactor
Lamp type	Low pressure high output 155 watts
Reactors	1
Banks per reactor	2
Modules per bank	3
Lamps per module	6
Lamps per bank	18
Lamps per project	36
Tubes	8
UV monitoring	0-100% - 4-20 ma
Lamp status	Green LEDs
Remote control	H/O/A
Voltage	120-277 Volt
kW/hr	2.8 kW per bank

Integration	
UV output	4-20 mA from UV
Flow signal	Required
Basic PLC	AB Micrologix 1100
Remote control	H/O/A

### Recommendations, Clarifications & Exceptions



The NONCON 5000 system can run from 120-277 Volts. Prior to design, we will need to determine the available power.

### **Our Fluoropolymer**

- Manufactured USA
- Use 100% virgin resins that increase performance and resists cracking.
- Inert to chemicals and solvents
- High UV transmission
- Resistant to fouling

### **Our System**

- Manufactured in USA
- Uses low pressure high output UV lamps
- Uses proven ballast technologies to run lamps 120-277 volt
- Commercial PLC by Allen Bradley (no custom components)
- UV sensor and UV monitor
- No quartz sleeves – tubes require less maintenance and do not foul

### **Scope of Engineering**

The following documentation will be provided by Glasco UV at the time of submittal:

Installation Operation and Maintenance manual, layout drawings, P+ID drawings, ladder logic diagrams, terminal block diagrams, Warranty requirements, long term storage requirements, bills of materials, equipment descriptions, equipment brochures, head loss calculations, UV DIS calculations, equipment installation lists and other relevant documentation.

### **Scope of Supply**

<b>Qty</b>	<b>Description</b>
One (1)	Two (2) Bank NONCON reactor with internal heat management system. Each bank has three (3) UV modules – each holding six (6) lamps. Eighteen (18) lamps per bank = thirty-six (36) lamps per project. Eight tubes will run through each bank.
One (1)	Ballast Control Center (BCC) NEMA 4X modified Type 304 SS enclosure. Includes LEDs, Run Time and UV monitoring systems.
One (1)	System Control Center AB PLC for alarming, bank pacing and other functions.

#### Spares

UV Lamps	3
Ballast	1
Brush	1
Operators safety kit	1
Operation Manuals	3

### **Commercial Offering**

<b>TERMS:</b>	Net 30 days	10% upon approved drawings 80% upon equipment delivery (or upon notification of ready and holding) 10% upon start-up or within six (6) months from delivery, whichever first
---------------	-------------	--



<b>FREIGHT:</b>	Included in proposal
<b>SUBMITTAL:</b>	4 to 6 weeks after release of order
<b>DELIVERY:</b>	12 to 14 weeks after receipt of approved submittals
<b>SITE START-UP:</b>	Included
<b>TRAINING:</b>	Included
<b>PRICE:</b>	BY EES

## NOTES

1. GLASCO UV's proposes to furnish materials and/or equipment for the above project. Any items not shown above as detailed under 'SCOPE OF SUPPLY', or other attachments to this proposal, are EXCLUDED.
2. Any order resulting from this proposal is subject to the GLASCO UV's Standard Terms of Sale in addition to the following understandings:
  - a. Prices noted will be held valid for a period of 90 days from the date of the proposal.
  - b. Prices are in US Dollars.
  - c. Local or state taxes are not included in this proposal.
3. Please send all purchase orders to Glasco UV, 126 Christie Street, Mahwah, NJ 07430.

## ***Items not included in our scope***

- a) Ventilation/air conditioning of shelter for electrical cabinet(s) to maintain indoor temperature below 104 F (if applicable; see actual temperature limit for control cabinet).
- b) Structure above UV modules to protect from direct heat as well as from inclement weather.
- c) Mechanical installation labor for installing equipment, cabling and instrumentation.
- d) Lightning surge protection and electrical ground connection.
- e) Valves for isolation of individual systems for dose pacing and/or maintenance/cleaning purposes
- f) Unloading of components supplied by GLASCO UV.
- g) Placement in storage of all components supplied by GLASCO UV.
- h) All required equipment, labor, analysis, etc. for any on-site biological performance tests that may be required (regular support for operational tests is provided).
- i) Supply and installation of electrical conduit and wiring for power supply and controls of UV system.
- j) Any civil and/or mechanical work required to support or install the UV system or its associated controls. This includes concrete pads.
- k) Power surge protection and lightning strike protection devices to be provided by contractor.
- l) All transformers, circuit breakers and disconnect devices prior to the UV system enclosures are to be provided by electrical contractor (in some cases the transformer is provided by Glasco).
- m) Labor and installation of UV modules, electrical enclosures, compressor and PLC.
- n) Contractor to supply stainless steel anchor bolts for component installation.
- o) Sun shields for all electrical enclosures. This is to prevent thermal gain resulting from exposure to direct sunlight. (Not needed if installed indoors)
- p) If supplied, remote signal communication to the SCADA system including language/protocol conversion software and hardware as required. Data retrieval of information from the PLCs is the responsibility of the SCADA system provider or integrator. This includes integration of flow signals.

## ***Warranty***

The warranty period is 18 months from date of delivery and 12 months from date of the Certification of Substantial Completion whichever comes first. It covers all failures due to defects in material and/or workmanship excluding consumables (see separate lamp and ballast warranties below).

This warranty shall not apply to any failure or defect which results from the Equipment not being operated and maintained in strict accordance with instructions specified in Glasco UV's Instructions Manual or which results from mishandling, misuse, neglect, improper storage, improper operation of the Equipment with other equipment furnished by the Customer or by other third parties or from defects in designs or specifications furnished by or on behalf of the Customer by a person other than Glasco UV. In addition, this warranty shall not apply to Equipment that has been altered or repaired after start-up by any one except:

- Authorized representatives of Glasco UV, or
- Customer acting under specific instructions from Glasco UV.

Customer must notify Glasco UV in writing within 5 days of the date of any Equipment failure. This notification shall include a description of the problem, a copy of the operator's log, a copy of the Customer's maintenance record and any analytical results detailing the problem. If Customer has not maintained the operator's log and maintenance record in the manner directed in the Operation and Maintenance manual, or does not notify Glasco UV of the problem as specified above, this warranty may, in Glasco UV's discretion, be invalid.



GLASCO UV

Customer will fully cooperate with Glasco UV, in the manner requested by Glasco UV, in attempting to diagnose and resolve the problem by way of telephone support. If the problem can be diagnosed by telephone support and a replacement part is required, Glasco UV will either, at Glasco UV's expense, ship a repaired, reworked or new part to the Customer who will install such part as directed by Glasco UV or will direct Customer to acquire, at Glasco UV's expense, such part from a third party and then install such part as directed by Glasco UV.

This warranty is the exclusive remedy of the Customer for all claims based on a failure of or defect in the Equipment, whether the claim is based on contract (including fundamental breach), tort (including negligence), strict liability or otherwise. This warranty is lieu of all other warranties whether written, oral, implied or statutory. Without limitation, no warranty of merchantability or fitness for a particular purpose shall apply to the Equipment.

### **Lamp Warranty**

Each low pressure, high output lamp is guaranteed for 13,000 hours operating time under normal operating conditions. Normal operating conditions include:

- On/off cycles max. 4 per 24 operating hours,
- Voltage fluctuations according to DIN IEC 38.

In case of premature lamp failure, the client is requested to send the lamp back to Glasco UV together with the information of UV unit serial number, hours run and on/off cycles. Glasco UV then offers the following:

- Lamp failure before 9,000 h: Glasco UV will send a replacement lamp free of charge,
- Lamp failure after 9,000 h: Glasco UV will issue a credit proportional to the hours not used.

Upon return to our facilities in Mahwah, NJ, we will dispose/recycle all used and failed lamps at no charge to the client.

## Terms & Conditions

1. **Applicable Terms.** These terms govern the purchase and sale of the equipment and related services, if any (collectively, "Equipment"), referred to in Seller's purchase order, quotation, proposal or acknowledgment, as the case may be ("Seller's Documentation"). Whether these terms are included in an offer or an acceptance by Seller, such offer or acceptance is conditioned on Buyer's assent to these terms. Seller rejects all additional or different terms in any of Buyer's forms or documents.
2. **Payment.** Buyer shall pay Seller the full purchase price as set forth in Seller's Documentation. Unless Seller's Documentation provides otherwise, freight, storage, insurance and all taxes, duties or other governmental charges relating to the Equipment shall be paid by Buyer. If Seller is required to pay any such charges, Buyer shall immediately reimburse Seller. All payments are due within 30 days after receipt of invoice. Buyer shall be charged the lower of 1 ½% interest per month or the maximum legal rate on all amounts not received by the due date and shall pay all of Seller's reasonable costs (including attorneys' fees) of collecting amounts due but unpaid. All orders are subject to credit approval.
3. **Delivery.** Delivery of the Equipment shall be in material compliance with the schedule in Seller's Documentation. Unless Seller's Documentation provides otherwise, Delivery terms are F.O.B. Seller's facility.
4. **Ownership of Materials.** All devices, designs (including drawings, plans and specifications), estimates, prices, notes, electronic data and other documents or information prepared or disclosed by Seller, and all related intellectual property rights, shall remain Seller's property. Seller grants Buyer a non-exclusive, non-transferable license to use any such material solely for Buyer's use of the Equipment. Buyer shall not disclose any such material to third parties without Seller's prior written consent.
5. **Changes.** Seller shall not implement any changes in the scope of work described in Seller's Documentation unless Buyer and Seller agree in writing to the details of the change and any resulting price, schedule or other contractual modifications. This includes any changes necessitated by a change in applicable law occurring after the effective date of any contract including these terms.
6. **Warranty.** Subject to the following sentence, Seller warrants to Buyer that the Equipment shall materially conform to the description in Seller's Documentation and shall be free from defects in material and workmanship. The foregoing warranty shall not apply to any Equipment that is specified or otherwise demanded by Buyer and is not manufactured or selected by Seller, as to which (i) Seller hereby assigns to Buyer, to the extent assignable, any warranties made to Seller and (ii) Seller shall have no other liability to Buyer under warranty, tort or any other legal theory. If Buyer gives Seller prompt written notice of breach of this warranty within 18 months from delivery or 1 year from acceptance, whichever occurs first (the "Warranty Period"), Seller shall, at its sole option and as Buyer's sole remedy, repair or replace the subject parts or refund the purchase price therefore. If Seller determines that any claimed breach is not, in fact, covered by this warranty, Buyer shall pay Seller its then customary charges for any repair or replacement made by Seller. Seller's warranty is conditioned on Buyer's (a) operating and maintaining the Equipment in accordance with Seller's instructions, (b) not making any unauthorized repairs or alterations, and (c) not being in default of any payment obligation to Seller. Seller's warranty does not cover damage caused by chemical action or abrasive material, misuse or improper installation (unless installed by Seller). THE WARRANTIES SET FORTH IN THIS SECTION ARE SELLER'S SOLE AND EXCLUSIVE WARRANTIES AND ARE SUBJECT TO SECTION 10 BELOW. SELLER MAKES NO OTHER WARRANTIES OF ANY KIND, EXPRESS OR IMPLIED, INCLUDING WITHOUT LIMITATION, ANY WARRANTY OF MERCHANTABILITY OR FITNESS FOR PURPOSE.
7. **Indemnity.** Seller shall indemnify, defend and hold Buyer harmless from any claim, cause of action or liability incurred by Buyer as a result of third party claims for personal injury, death or damage to tangible property, to the extent caused by Seller's negligence. Seller shall have the sole authority to direct the defense of and settle any indemnified claim. Seller's indemnification is conditioned on Buyer (a) promptly, within the Warranty Period, notifying Seller of any claim, and (b) providing reasonable cooperation in the defense of any claim.
8. **Force Majeure.** Neither Seller nor Buyer shall have any liability for any breach (except for breach of payment obligations) caused by extreme weather or other act of God, strike or other labor shortage or disturbance, fire, accident, war or civil disturbance, delay of carriers, failure of normal sources of supply, act of government or any other cause beyond such party's reasonable control.
9. **Cancellation.** If Buyer cancels or suspends its order for any reason other than Seller's breach, Buyer shall promptly pay Seller for work performed prior to cancellation or suspension and any other direct costs incurred by Seller as a result of such cancellation or suspension.
10. **LIMITATION OF LIABILITY.** NOTWITHSTANDING ANYTHING ELSE TO THE CONTRARY, SELLER SHALL NOT BE LIABLE FOR ANY CONSEQUENTIAL, INCIDENTAL, SPECIAL, PUNITIVE OR OTHER INDIRECT DAMAGES, AND SELLER'S TOTAL LIABILITY ARISING AT ANY TIME FROM THE SALE OR USE OF THE EQUIPMENT SHALL NOT EXCEED THE PURCHASE PRICE PAID FOR THE EQUIPMENT. THESE LIMITATIONS APPLY WHETHER THE LIABILITY IS BASED ON CONTRACT, TORT, STRICT LIABILITY OR ANY OTHER THEORY.
11. **Reservation Clause.** Buyer acknowledges that Seller is required to comply with applicable export laws and regulations relating to the sale, exportation, transfer, assignment, disposal and usage of the Equipment provided under this Agreement, including any export license requirements. Buyer agrees that such Equipment shall not at any time directly or indirectly be used, exported, sold, transferred, assigned or otherwise disposed of in a manner which will result in non-compliance with such applicable export laws and regulations. It shall be a condition of the continuing performance by Seller of its obligations hereunder that compliance with such export laws and regulations be maintained at all times. BUYER AGREES TO INDEMNIFY AND HOLD SELLER HARMLESS FROM ANY AND ALL COSTS, LIABILITIES, PENALTIES, SANCTIONS AND FINES RELATED TO NON-COMPLIANCE WITH APPLICABLE EXPORT LAWS AND REGULATIONS.
12. **Miscellaneous.** If these terms are issued in connection with a government contract, they shall be deemed to include those federal acquisition regulations that are required by law to be included. These terms, together with any quotation, purchase order or acknowledgement issued or signed by the Seller, comprise the complete and exclusive statement of the agreement between the parties (the "Agreement") and supersede any terms contained in Buyer's documents, unless separately signed by Seller. No part of the Agreement may be changed or cancelled except by a written document signed by Seller and Buyer. No course of dealing or performance, usage of trade or failure to enforce any term shall be used to modify the Agreement. If any of these terms is unenforceable, such term shall be limited only to the extent necessary to make it enforceable, and all other terms shall remain in full force and effect. Buyer may not assign or permit any other transfer of the Agreement without Seller's prior written consent. The Agreement shall be governed by the laws of the State of New Jersey without regard to its conflict of laws provisions.

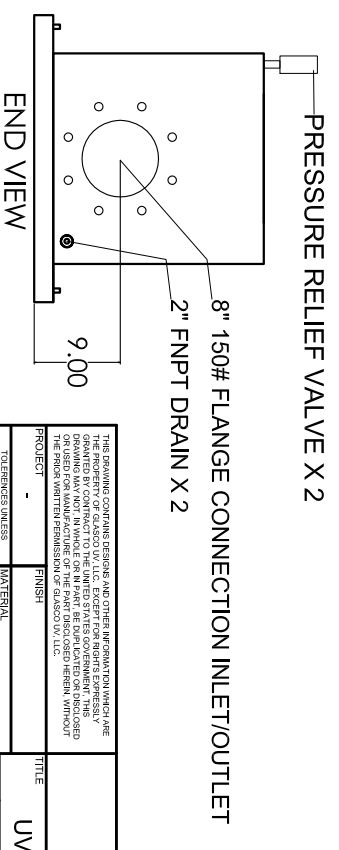
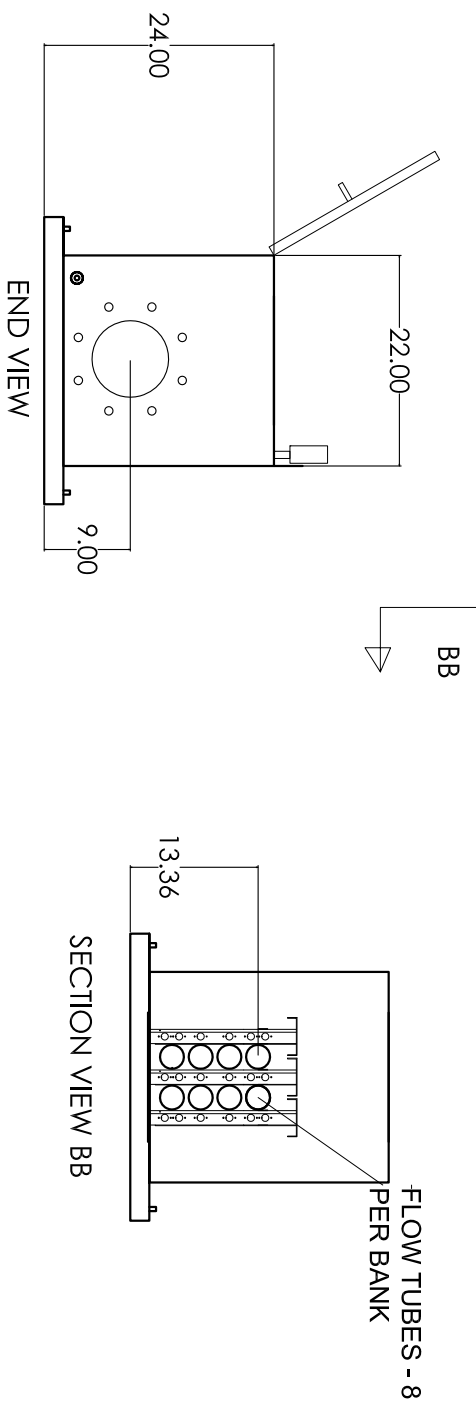
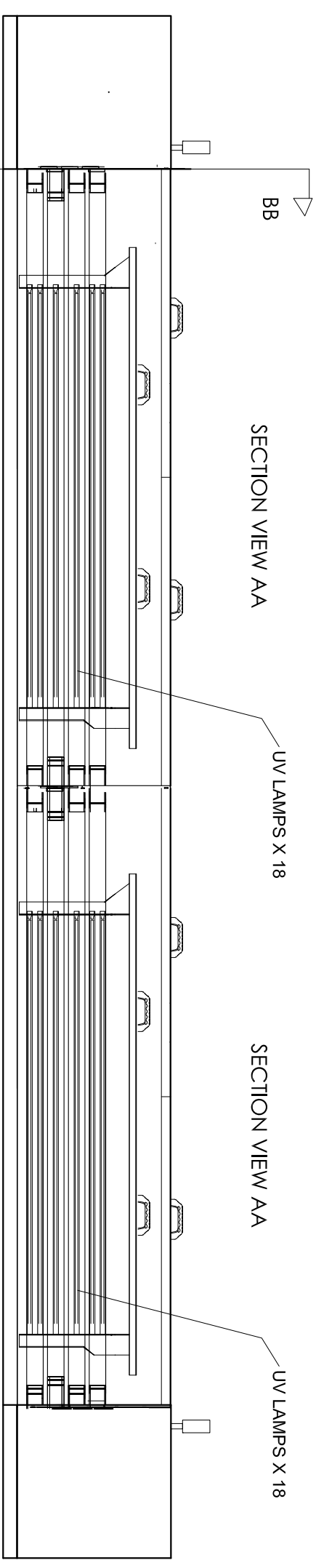
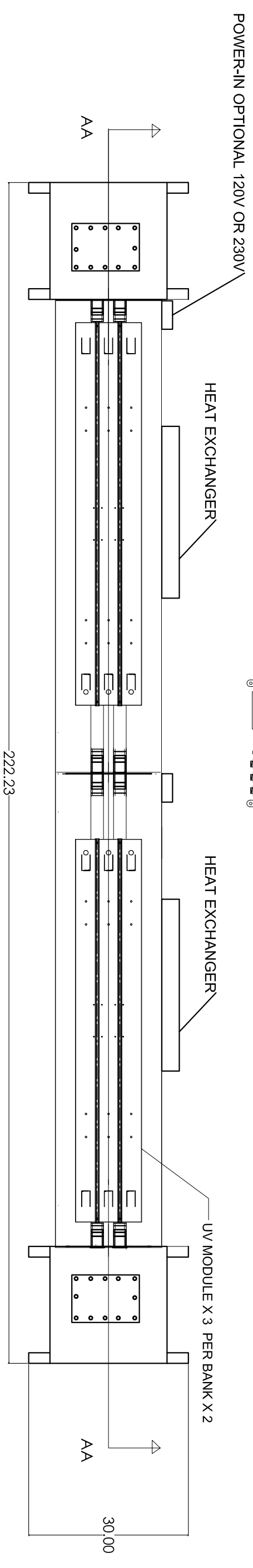
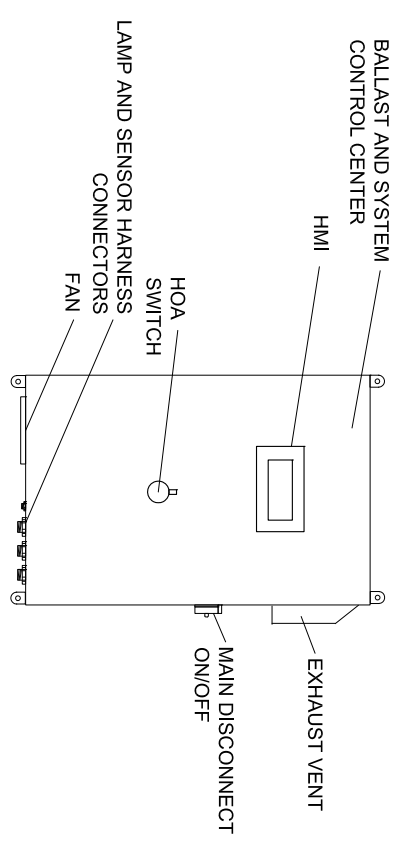

THIS DRAWING CONTAINS SECTIONS AND OTHER INFORMATION WHICH ARE THE PROPERTY OF GLASCO UV, LLC. ANY REPRODUCTION OR TRANSMISSION OF THIS DRAWING WITHOUT THE WRITTEN PERMISSION OF GLASCO UV, LLC IS STRICTLY PROHIBITED.

PROJECT	FINISH	TITLE
TO: RICHMOND SERVICES	UNSATURATED	UV EQUIPMENT LAYOUT
DATE: 2014.05.11	DATE: 2014.05.11	SCALE: N/A
BY: JAC	BY: RV	SHEET 1 OF 1
DATE: 2014.05.11	DATE: 2014.05.11	

126 Christie Avenue, Marlborough, MA 01752  
 Phone: 508-253-5500  
 WWW.GLASCOUV.COM

# NONCON

## S E R I E S



### PRODUCT OVERVIEW

The “NONCON 5000” Series is a “flow through” fluoropolymer style of ultraviolet (UV) water and wastewater disinfection systems.

Unlike our other systems where the UV lamps are immersed in the water (using protective quartz sleeves), the “NONCON 5000” uses non conductive transparent fluoropolymer tubes to transport the water close to the UV lamps.

The UV lamps are positioned in the air and shine germicidal rays (@ 254 nm) through the fluoropolymer tubes directly at their intended targets, microorganisms. Lamps are not in the water.

### STANDARD FEATURES

- Stainless steel disinfection reactor **OR**
- Open channel insert for large flows
- Low-pressure high-output UV lamps
- Fluoropolymer flow through tubes
- Multi-voltage power (120-277)
- UV monitoring
- Lamp status and run time indicators
- 45 psi pressure-rated
- Remote electronics
- Environmental temperature management
- Air release valves
- Drain ports

NONCON 5000



GLASCO UV

## NONCON UV DISINFECTION SYSTEMS

Systems use special fluoropolymer (FEP) tubes to transport water, wastewater and other liquids in close proximity to the UV lamps. The fluoropolymer tubes are transparent and allow UV light in the 254 nm range to penetrate the tube's walls and disable microorganisms. Lamps are positioned around the tubes in a reflective reactor.

The tubes are manufactured in the United States from a high quality polymer resin. The tubes, which are highly transparent, are neutrally charged (the "non-conductive" in "NONCON") and thus, not susceptible to fouling and scaling from positively charged minerals. In traditional UV systems, the quartz sleeves need to be cleaned.

Over 100 years ago, scientists found that when pathogens were exposed to UV light, their reproduction was limited. The light resided in the UVC range of the spectrum. Specifically, they discovered that light in the 254 nanometer (nm) range was the most effective. When pathogens are exposed to UV light, their cells become damaged and this inhibits reproduction. UV light damages the cell's DNA and RNA and once damaged, they are unable to replicate and therefore, rendered harmless.

The amount of damage is a result of the intensity of the UV light multiplied by the time the water is exposed to the light (time x intensity). The dosage, referred to as microwatts, is often expressed as mJ/cm<sup>2</sup>. Doses > 30,000 microwatt dose (30 mJ) are accepted for wastewater disinfection.

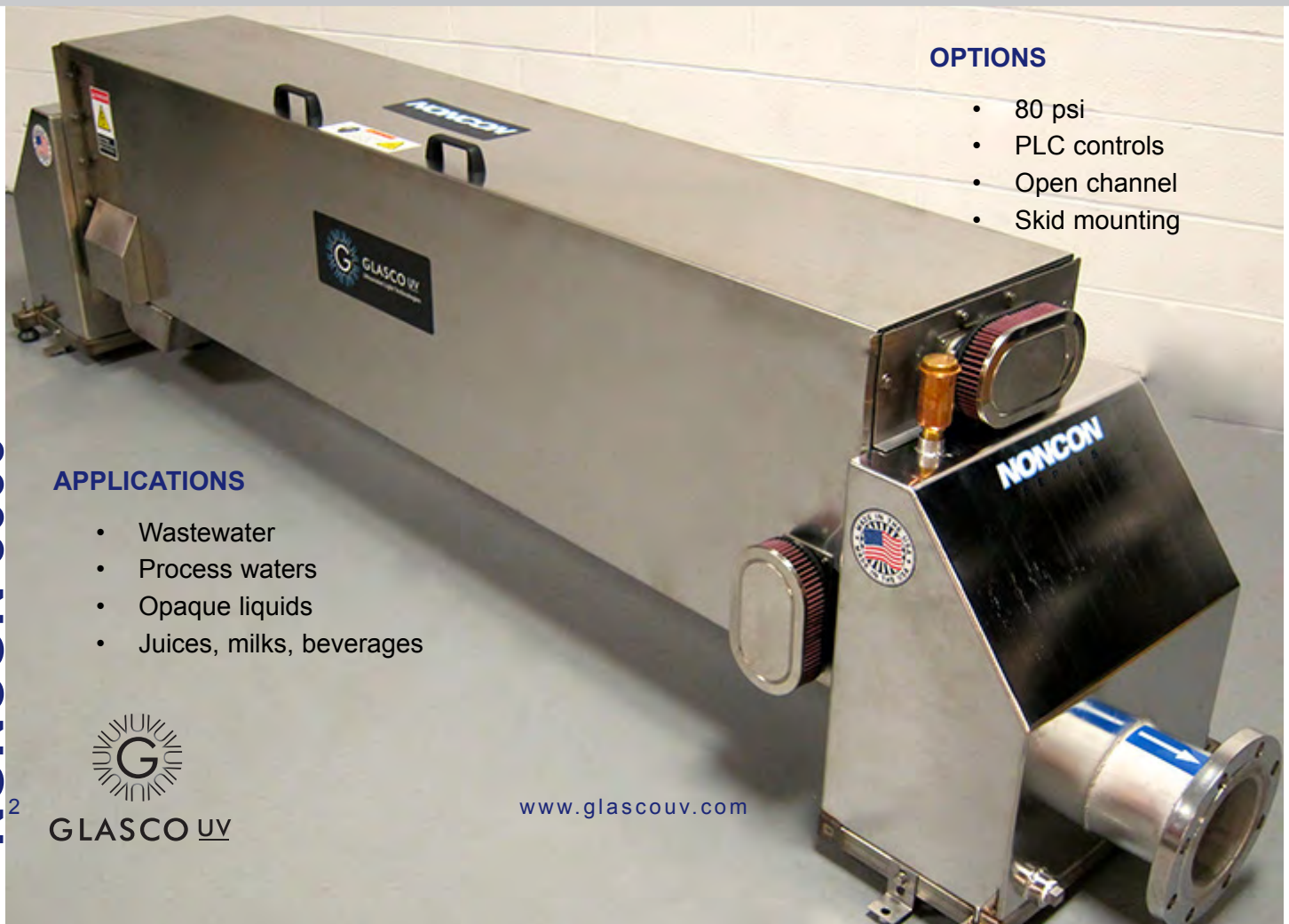

### OPTIONS

- 80 psi
- PLC controls
- Open channel
- Skid mounting

### APPLICATIONS

- Wastewater
- Process waters
- Opaque liquids
- Juices, milks, beverages

NONCON 5000



GLASCO UV

[www.glascouv.com](http://www.glascouv.com)



**NONCON 5000**

**NONCON OPERATION**

Facility connects to the “NONCON” reactor via flange or in the case of larger projects, directly into a poured concrete channel. Water or wastewater enters a pressurized transition box and then feeds into a bank of transparent tubes. Water and wastewater travels through the tubes and exits into the discharge pressure box. Tubes are rated at 45 psi.

Systems are designed based on a peak flow rate, a UV transmission percentage (UVT%) and information related to the plant’s discharge permit. The number of tubes and associated UV lamps are based on the biological testing (bioassay) testing and computational fluid dynamic (CFD) modeling.

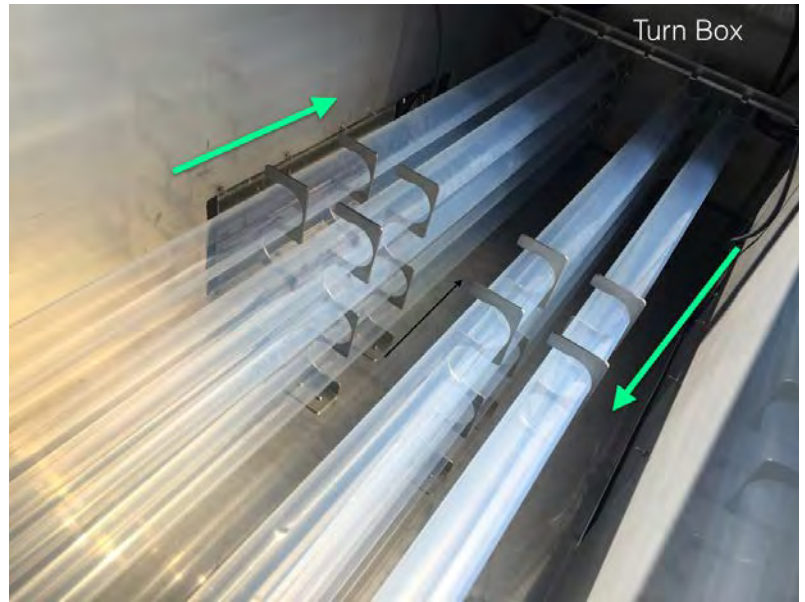

**NONCON OPERATION (SYSTEM CONTROLS AND REDUNDANCY)**

NONCON uses a remote Ballast Control Center (BCC). This stainless steel enclosure provides a single point of control for operators and removes sensitive components from reactor, which may be damaged in the event of moisture or flooding. The BCC houses ballasts, power controls, operating displays and UV monitor in a controlled environment. NONCON lamps (low-pressure high-output) are sensitive to temperature. To maintain optimal lamp temperature, reactor will be provided with a heat exchanger.

System has flexibility when designing for redundancy. Standalone, banks “in-series”, “U-turn” box (shown above) or in parallel. Unlike traditional open channel UV systems, the FEP tube systems have very low maintenance costs due to the lack of quartz sleeve fouling.

**NONCON 5000**







# UV DISINFECTION PROJECT PROPOSAL

## NONCON S E R I E S

<b>Project Name:</b>	Lone Tree IOWA
<b>Proposal Number:</b>	ATD-07112016-1
<b>Date:</b>	September 9, 2016

<b>Prepared by:</b>	<b>Adam Donnellan</b> VP Sales
Email	<a href="mailto:adam@glascouv.com">adam@glascouv.com</a>
Mobile	201 785-4357

<b>Prepared for:</b>	<b>Matt Streeter</b>
Company	Engineered Equipment Solutions
Email	<a href="mailto:mstreeter@e-equipmentsolutions.com">mstreeter@e-equipmentsolutions.com</a>
Phone	<a href="tel:515-450-8803">515-450-8803</a>
Address	

<b>Project Type:</b>	<b>Wastewater</b>
Type	Fluoropolymer Tube
Orientation	Horizontal – Stainless Steel reactor 2 Banks
System Name	NONCON-5000-5-7 x 20
Lamp Technology	Low pressure high output 155 W
Flow rate range	1.1 MGD 55% UVT 12" Inlet



### BENEFITS OF NONCON 5000

- No quartz sleeves
- Flow through FEP tubes remain clean
- Energy efficient low pressure high output lamps
- Economical lamp costs

### TYPICAL EQUIPMENT

#### Standard

- Stainless steel reactor with inlet and outlet
- 2 Banks in series
- Remote NEMA 4x ballast control center with run time and lamp status
- UV monitoring
- PLC monitoring (AB Micrologix)

#### By Others

- Inlet isolation gate
- Integration

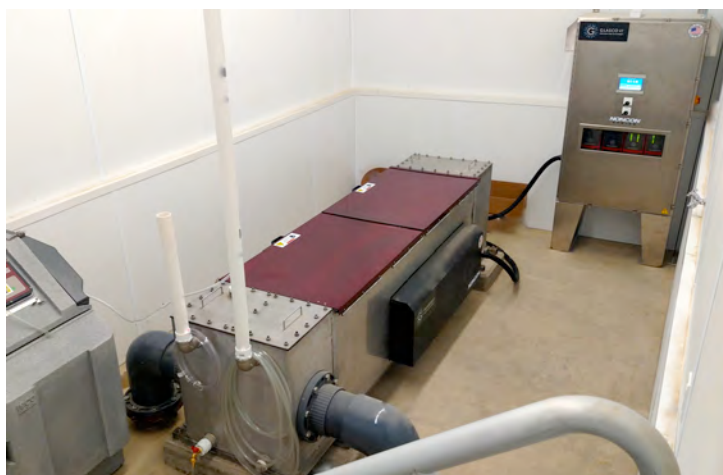

## Design Information

### DESIGN OVERVIEW

Application	Wastewater
Peak flow	2.224 mgd
Flow per bank	1.1 MGD
Start up flow	200,000 GPD
Minimum flow	0.00
Location	Indoors

Water Quality	
UV transmission %	50%-55%
Influent counts	200,000 fc/100 ml
Water temp.	46-75° F
TSS	<30 mg/l
BOD	<30 mg/l
Discharge permit	<126 fc/100 ml
Design UV dosage	>30,000 uWs/cm <sup>2</sup> @ end of lamp life

Dimensions	
Channel length	210"
Channel width	34"
Channel height	37"
Connections	12" pattern
Ballast Control Center	NEMA 4x stainless steel free standing

### EQUIPMENT OVERVIEW

Model Name	NONCON-5000-5-7x 20
System type	Horizontal
Configuration	Reactor
Lamp type	Low pressure high output 155 watts
Reactors	1
Banks per reactor	2
Modules per bank	5
Lamps per module	7
Lamps per bank	35
Lamps per project	70
Tubes	20
UV monitoring	0-100% - 4-20 ma
Lamp status	Green LEDs
Remote control	H/O/A
Voltage	120-277 Volt
kW/hr	5.5 kW per bank

Integration	
UV output	4-20 mA from UV
Flow signal	Required
Basic PLC	AB Micrologix 1100
Remote control	H/O/A

## Recommendations, Clarifications & Exceptions

The NONCON 5000 system can run from 120-277 Volts. Prior to design, we will need to determine the available power.

### Our Fluoropolymer

- Manufactured USA
- Use 100% virgin resins
- Inert to chemicals and solvents
- High UV transmission
- Resistant to fouling

### Our System

- Manufactured in USA
- Uses low pressure high output UV lamps
- Uses proven ballast technologies to run lamps 120-277 volt
- Commercial PLC by Allen Bradley (no custom components)
- UV sensor and UV monitor
- No quartz sleeves – tubes require less maintenance and do not foul

## Scope of Engineering

The following documentation will be provided by Glasco UV at the time of submittal:

Installation Operation and Maintenance manual, layout drawings, P+ID drawings, ladder logic diagrams, terminal block diagrams, Warranty requirements, long term storage requirements, bills of materials, equipment descriptions, equipment brochures, head loss calculations, UV DIS calculations, equipment installation lists and other relevant documentation.

## Scope of Supply

Qty	Description
One (1)	NONCON reactor with internal heat management system. Cooling pumps will be supplied.
Two (2)	Banks each bank having five (5) UV modules – each holding seven (7) lamps. Thirty - five (35) lamps per bank. Twenty (20) tubes will extend through reactor.
One (1)	Ballast Control Center (BCC) NEMA 4X modified Type 304 SS free standing enclosure. Includes LEDs, Run Time and UV monitoring systems.
One (1)	System Control Center PLC for alarming, bank pacing and other functions.

### Spares

UV Lamps	4
Ballasts	2
Operator safety kit	1
Operation Manuals	3

## Commercial Offering

<b>TERMS:</b>	Net 30 days	10% upon approved drawings 80% upon equipment delivery (or upon notification of ready and holding) 10% upon start-up or within six (6) months from delivery, whichever first
<b>FREIGHT:</b>	Included in proposal	
<b>SUBMITTAL:</b>	4 to 6 weeks after release of order	
<b>DELIVERY:</b>	14 weeks after receipt of approved submittals	
<b>SITE START-UP:</b>	Included	
<b>TRAINING:</b>	Included	
<b>PRICE:</b>	BY EES Matt Streeter	

### NOTES

- GLASCO UV's proposes to furnish materials and/or equipment for the above project. Any items not shown above as detailed under 'SCOPE OF SUPPLY', or other attachments to this proposal, are EXCLUDED.
- Any order resulting from this proposal is subject to the GLASCO UV's Standard Terms of Sale in addition to the following understandings:
  - Prices noted will be held valid for a period of 90 days from the date of the proposal.

- b. Prices are in US Dollars.
  - c. Local or state taxes are not included in this proposal.
3. Please send all purchase orders to Glasco UV, 126 Christie Street, Mahwah, NJ 07430.

### **Items not included in our scope**

- a) Ventilation/air conditioning of shelter for electrical cabinet(s) to maintain indoor temperature below 104 F (if applicable; see actual temperature limit for control cabinet).
- b) Structure above UV modules to protect from direct heat as well as from inclement weather.
- c) Mechanical installation labor for installing equipment, cabling and instrumentation.
- d) Lightning surge protection and electrical ground connection.
- e) Valves for isolation of individual systems for dose pacing and/or maintenance/cleaning purposes
- f) Unloading of components supplied by GLASCO UV.
- g) Placement in storage of all components supplied by GLASCO UV.
- h) All required equipment, labor, analysis, etc. for any on-site biological performance tests that may be required (regular support for operational tests is provided).
- i) Supply and installation of electrical conduit and wiring for power supply and controls of UV system.
- j) Any civil and/or mechanical work required to support or install the UV system or its associated controls. This includes concrete pads.
- k) Power surge protection and lightning strike protection devices to be provided by contractor.
- l) All transformers, circuit breakers and disconnect devices prior to the UV system enclosures are to be provided by electrical contractor (in some cases the transformer is provided by Glasco).
- m) Labor and installation of UV modules, electrical enclosures, compressor and PLC.
- n) Contractor to supply stainless steel anchor bolts for component installation.
- o) Sun shields for all electrical enclosures. This is to prevent thermal gain resulting from exposure to direct sunlight. (Not needed if installed indoors)
- p) If supplied, remote signal communication to the SCADA system including language/protocol conversion software and hardware as required. Data retrieval of information from the PLCs is the responsibility of the SCADA system provider or integrator. This includes integration of flow signals.

### **Warranty**

The warranty period is 18 months from date of delivery and 12 months from date of the Certification of Substantial Completion whichever comes first. It covers all failures due to defects in material and/or workmanship excluding consumables (see separate lamp and ballast warranties below).

This warranty shall not apply to any failure or defect which results from the Equipment not being operated and maintained in strict accordance with instructions specified in Glasco UV's Instructions Manual or which results from mishandling, misuse, neglect, improper storage, improper operation of the Equipment with other equipment furnished by the Customer or by other third parties or from defects in designs or specifications furnished by or on behalf of the Customer by a person other than Glasco UV. In addition, this warranty shall not apply to Equipment that has been altered or repaired after start-up by any one except:

- Authorized representatives of Glasco UV, or
- Customer acting under specific instructions from Glasco UV.

Customer must notify Glasco UV in writing within 5 days of the date of any Equipment failure. This notification shall include a description of the problem, a copy of the operator's log, a copy of the Customer's maintenance record and any analytical results detailing the problem. If Customer has not maintained the operator's log and maintenance record in the manner directed in the Operation and Maintenance manual, or does not notify Glasco UV of the problem as specified above, this warranty may, in Glasco UV's discretion, be invalid.

Customer will fully cooperate with Glasco UV, in the manner requested by Glasco UV, in attempting to diagnose and resolve the problem by way of telephone support. If the problem can be diagnosed by telephone support and a replacement part is required, Glasco UV will either, at Glasco UV's expense, ship a repaired, reworked or new part to the Customer who will install such part as directed by Glasco UV or will direct Customer to acquire, at Glasco UV's expense, such part from a third party and then install such part as directed by Glasco UV.

This warranty is the exclusive remedy of the Customer for all claims based on a failure of or defect in the Equipment, whether the claim is based on contract (including fundamental breach), tort (including negligence), strict liability or otherwise. This warranty is lieu of all other warranties whether written, oral, implied or statutory. Without limitation, no warranty of merchantability or fitness for a particular purpose shall apply to the Equipment.

#### **Lamp Warranty**

Each low pressure, high output lamp is guaranteed for 13,000 hours operating time under normal operating conditions. Normal operating conditions include:

- On/off cycles max. 4 per 24 operating hours,
- Voltage fluctuations according to DIN IEC 38.

In case of premature lamp failure, the client is requested to send the lamp back to Glasco UV together with the information of UV unit serial number, hours run and on/off cycles. Glasco UV then offers the following:

- Lamp failure before 9,000 h: Glasco UV will send a replacement lamp free of charge,
- Lamp failure after 9,000 h: Glasco UV will issue a credit proportional to the hours not used.

Upon return to our facilities in Mahwah, NJ, we will dispose/recycle all used and failed lamps at no charge to the client.

## Terms & Conditions

1. Applicable Terms. These terms govern the purchase and sale of the equipment and related services, if any (collectively, "Equipment"), referred to in Seller's purchase order, quotation, proposal or acknowledgment, as the case may be ("Seller's Documentation"). Whether these terms are included in an offer or an acceptance by Seller, such offer or acceptance is conditioned on Buyer's assent to these terms. Seller rejects all additional or different terms in any of Buyer's forms or documents.
2. Payment. Buyer shall pay Seller the full purchase price as set forth in Seller's Documentation. Unless Seller's Documentation provides otherwise, freight, storage, insurance and all taxes, duties or other governmental charges relating to the Equipment shall be paid by Buyer. If Seller is required to pay any such charges, Buyer shall immediately reimburse Seller. All payments are due within 30 days after receipt of invoice. Buyer shall be charged the lower of 1 ½% interest per month or the maximum legal rate on all amounts not received by the due date and shall pay all of Seller's reasonable costs (including attorneys' fees) of collecting amounts due but unpaid. All orders are subject to credit approval.
3. Delivery. Delivery of the Equipment shall be in material compliance with the schedule in Seller's Documentation. Unless Seller's Documentation provides otherwise, Delivery terms are F.O.B. Seller's facility.
4. Ownership of Materials. All devices, designs (including drawings, plans and specifications), estimates, prices, notes, electronic data and other documents or information prepared or disclosed by Seller, and all related intellectual property rights, shall remain Seller's property. Seller grants Buyer a non-exclusive, non-transferable license to use any such material solely for Buyer's use of the Equipment. Buyer shall not disclose any such material to third parties without Seller's prior written consent.
5. Changes. Seller shall not implement any changes in the scope of work described in Seller's Documentation unless Buyer and Seller agree in writing to the details of the change and any resulting price, schedule or other contractual modifications. This includes any changes necessitated by a change in applicable law occurring after the effective date of any contract including these terms.
6. Warranty. Subject to the following sentence, Seller warrants to Buyer that the Equipment shall materially conform to the description in Seller's Documentation and shall be free from defects in material and workmanship. The foregoing warranty shall not apply to any Equipment that is specified or otherwise demanded by Buyer and is not manufactured or selected by Seller, as to which (i) Seller hereby assigns to Buyer, to the extent assignable, any warranties made to Seller and (ii) Seller shall have no other liability to Buyer under warranty, tort or any other legal theory. If Buyer gives Seller prompt written notice of breach of this warranty within 18 months from delivery or 1 year from acceptance, whichever occurs first (the "Warranty Period"), Seller shall, at its sole option and as Buyer's sole remedy, repair or replace the subject parts or refund the purchase price therefore. If Seller determines that any claimed breach is not, in fact, covered by this warranty, Buyer shall pay Seller its then customary charges for any repair or replacement made by Seller. Seller's warranty is conditioned on Buyer's (a) operating and maintaining the Equipment in accordance with Seller's instructions, (b) not making any unauthorized repairs or alterations, and (c) not being in default of any payment obligation to Seller. Seller's warranty does not cover damage caused by chemical action or abrasive material, misuse or improper installation (unless installed by Seller). THE WARRANTIES SET FORTH IN THIS SECTION ARE SELLER'S SOLE AND EXCLUSIVE WARRANTIES AND ARE SUBJECT TO SECTION 10 BELOW. SELLER MAKES NO OTHER WARRANTIES OF ANY KIND, EXPRESS OR IMPLIED, INCLUDING WITHOUT LIMITATION, ANY WARRANTY OF MERCHANTABILITY OR FITNESS FOR PURPOSE.
7. Indemnity. Seller shall indemnify, defend and hold Buyer harmless from any claim, cause of action or liability incurred by Buyer as a result of third party claims for personal injury, death or damage to tangible property, to the extent caused by Seller's negligence. Seller shall have the sole authority to direct the defense of and settle any indemnified claim. Seller's indemnification is conditioned on Buyer (a) promptly, within the Warranty Period, notifying Seller of any claim, and (b) providing reasonable cooperation in the defense of any claim.
8. Force Majeure. Neither Seller nor Buyer shall have any liability for any breach (except for breach of payment obligations) caused by extreme weather or other act of God, strike or other labor shortage or disturbance, fire, accident, war or civil disturbance, delay of carriers, failure of normal sources of supply, act of government or any other cause beyond such party's reasonable control.
9. Cancellation. If Buyer cancels or suspends its order for any reason other than Seller's breach, Buyer shall promptly pay Seller for work performed prior to cancellation or suspension and any other direct costs incurred by Seller as a result of such cancellation or suspension.
10. LIMITATION OF LIABILITY. NOTWITHSTANDING ANYTHING ELSE TO THE CONTRARY, SELLER SHALL NOT BE LIABLE FOR ANY CONSEQUENTIAL, INCIDENTAL, SPECIAL, PUNITIVE OR OTHER INDIRECT DAMAGES, AND SELLER'S TOTAL LIABILITY ARISING AT ANY TIME FROM THE SALE OR USE OF THE EQUIPMENT SHALL NOT EXCEED THE PURCHASE PRICE PAID FOR THE EQUIPMENT. THESE LIMITATIONS APPLY WHETHER THE LIABILITY IS BASED ON CONTRACT, TORT, STRICT LIABILITY OR ANY OTHER THEORY.
11. Reservation Clause. Buyer acknowledges that Seller is required to comply with applicable export laws and regulations relating to the sale, exportation, transfer, assignment, disposal and usage of the Equipment provided under this Agreement, including any export license requirements. Buyer agrees that such Equipment shall not at any time directly or indirectly be used, exported, sold, transferred, assigned or otherwise disposed of in a manner which will result in non-compliance with such applicable export laws and regulations. It shall be a condition of the continuing performance by Seller of its obligations hereunder that compliance with such export laws and regulations be maintained at all times. BUYER AGREES TO INDEMNIFY AND HOLD SELLER HARMLESS FROM ANY AND ALL COSTS, LIABILITIES, PENALTIES, SANCTIONS AND FINES RELATED TO NON-COMPLIANCE WITH APPLICABLE EXPORT LAWS AND REGULATIONS.
12. Miscellaneous. If these terms are issued in connection with a government contract, they shall be deemed to include those federal acquisition regulations that are required by law to be included. These terms, together with any quotation, purchase order or acknowledgement issued or signed by the Seller, comprise the complete and exclusive statement of the agreement between the parties (the "Agreement") and supersede any terms contained in Buyer's documents, unless separately signed by Seller. No part of the Agreement may be changed or cancelled except by a written document signed by Seller and Buyer. No course of dealing or performance, usage of trade or failure to enforce any term shall be used to modify the Agreement. If any of these terms is unenforceable, such term shall be limited only to the extent necessary to make it enforceable, and all other terms shall remain in full force and effect. Buyer may not assign or permit any other transfer of the Agreement without Seller's prior written consent. The Agreement shall be governed by the laws of the State of New Jersey without regard to its conflict of laws provisions.

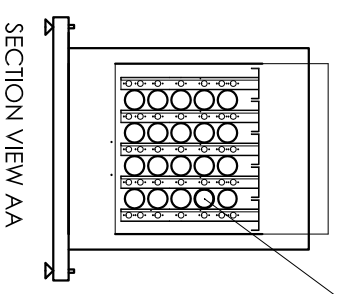
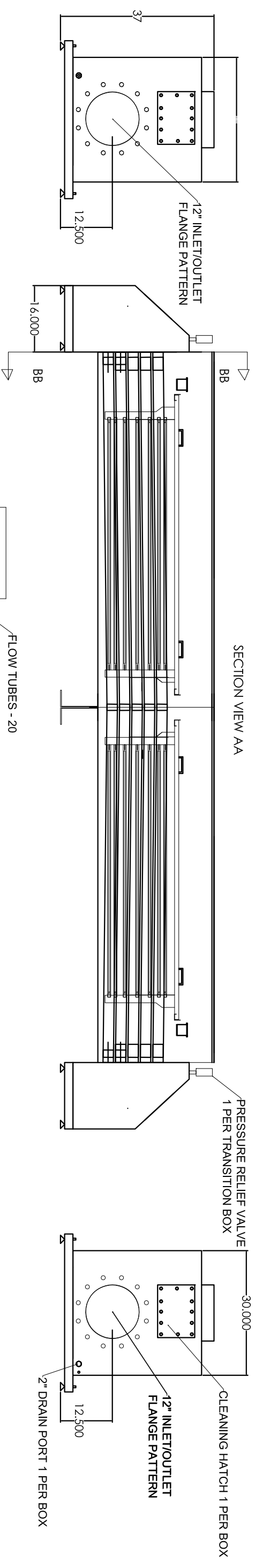
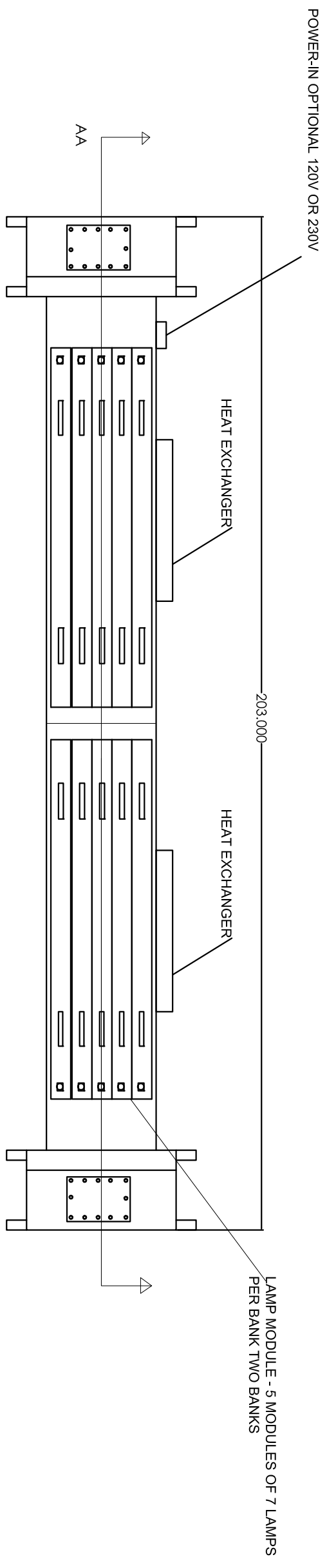

THIS DRAWING CONTAINS DESIGN AND OTHER INFORMATION WHICH ARE THE PROPERTY OF GLASCO UV, LLC. ANY REPRODUCTION OR TRANSMISSION OF THIS DRAWING WITHOUT THE WRITTEN PERMISSION OF GLASCO UV, LLC IS STRICTLY PROHIBITED. THE USER OF THIS DRAWING AGREES TO HOLD GLASCO UV, LLC HARMLESS FROM AND IN DEFENSE OF THE PARTIES CONTRACTED THEREON FOR THE DESIGN AND INVENTION OF THE PATENT RIGHTS AND INTELLECTUAL PROPERTY RIGHTS OF THE PARTIES CONTRACTED THEREON.

PROJECT	FINISH	TITLE
NONCON-5 X 7 -20	INTERMEDIATE	NONCON-5 X 7 -20
TOLERANCES UNLESS OTHERWISE SPECIFIED	SIZE	DWG. NO.
±.005	D	-
±.015	DMN	
±.030	RV	
±.060		
±.125		
DO NOT SCALE DRAWING	APPROV	SHEET
		OF

Glasco UV, LLC  
31 Industrial Ave Mahwah, NJ 07430  
PH: 201-924-3348 FX: 201-924-3388

# NONCON

## S E R I E S



### PRODUCT OVERVIEW

The “NONCON 5000” Series is a “flow through” fluoropolymer style of ultraviolet (UV) water and wastewater disinfection systems.

Unlike our other systems where the UV lamps are immersed in the water (using protective quartz sleeves), the “NONCON 5000” uses non conductive transparent fluoropolymer tubes to transport the water close to the UV lamps.

The UV lamps are positioned in the air and shine germicidal rays (@ 254 nm) through the fluoropolymer tubes directly at their intended targets, microorganisms. Lamps are not in the water.

### STANDARD FEATURES

- Stainless steel disinfection reactor **OR**
- Open channel insert for large flows
- Low-pressure high-output UV lamps
- Fluoropolymer flow through tubes
- Multi-voltage power (120-277)
- UV monitoring
- Lamp status and run time indicators
- 45 psi pressure-rated
- Remote electronics
- Environmental temperature management
- Air release valves
- Drain ports

NONCON 5000



GLASCO UV

## NONCON UV DISINFECTION SYSTEMS

Systems use special fluoropolymer (FEP) tubes to transport water, wastewater and other liquids in close proximity to the UV lamps. The fluoropolymer tubes are transparent and allow UV light in the 254 nm range to penetrate the tube's walls and disable microorganisms. Lamps are positioned around the tubes in a reflective reactor.

The tubes are manufactured in the United States from a high quality polymer resin. The tubes, which are highly transparent, are neutrally charged (the “**non-conductive**” in “NONCON”) and thus, not susceptible to fouling and scaling from positively charged minerals. In traditional UV systems, the quartz sleeves need to be cleaned.

Over 100 years ago, scientists found that when pathogens were exposed to UV light, their reproduction was limited. The light resided in the UVC range of the spectrum. Specifically, they discovered that light in the 254 nanometer (nm) range was the most effective. When pathogens are exposed to UV light, their cells become damaged and this inhibits reproduction. UV light damages the cell's DNA and RNA and once damaged, they are unable to replicate and therefore, rendered harmless.

The amount of damage is a result of the intensity of the UV light multiplied by the time the water is exposed to the light (time x intensity). The dosage, referred to as microwatts, is often expressed as mJ/cm<sup>2</sup>. Doses > 30,000 microwatt dose (30 mJ) are accepted for wastewater disinfection.

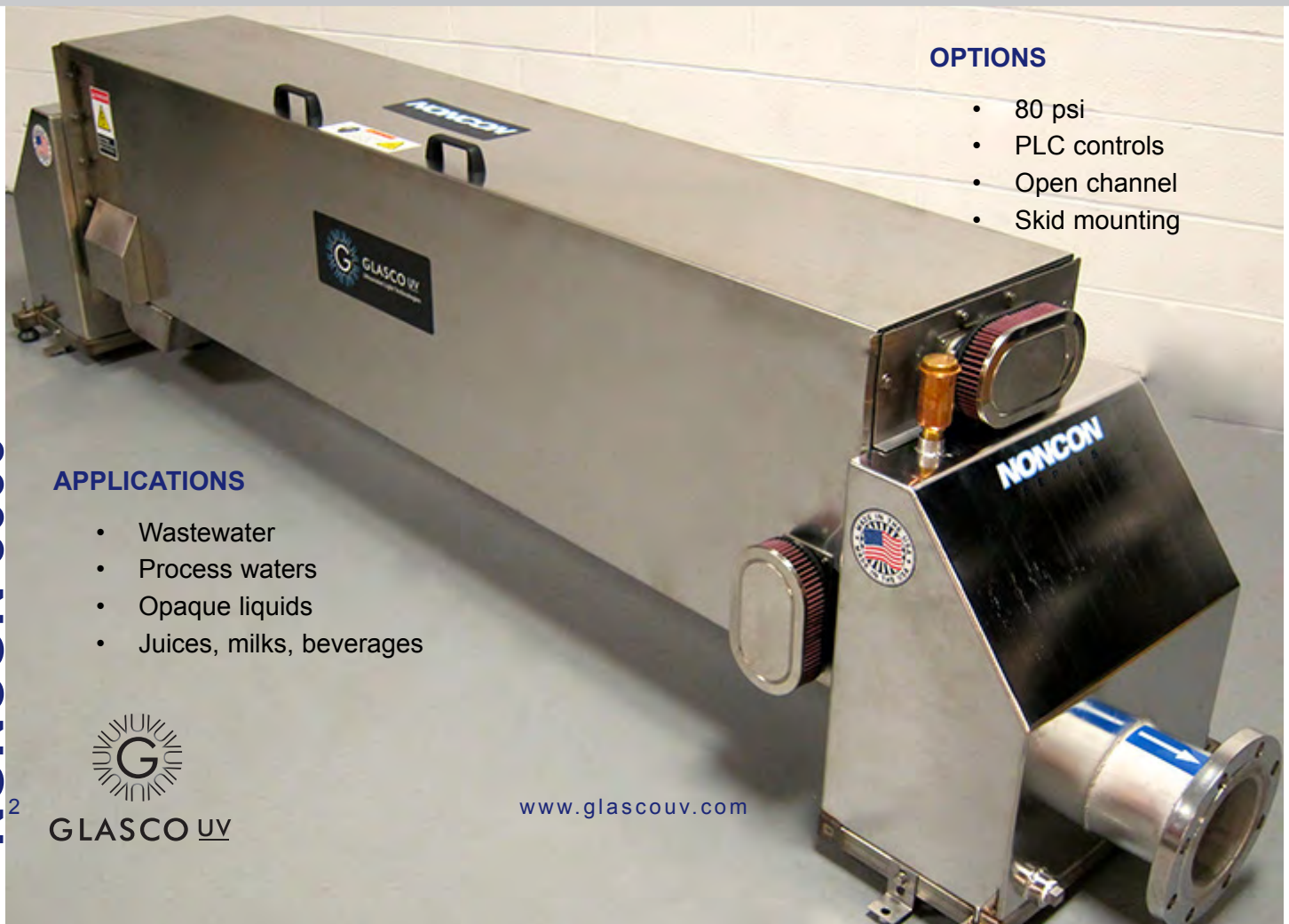

### OPTIONS

- 80 psi
- PLC controls
- Open channel
- Skid mounting

### APPLICATIONS

- Wastewater
- Process waters
- Opaque liquids
- Juices, milks, beverages

NONCON 5000



GLASCO UV

[www.glascouv.com](http://www.glascouv.com)





**NONCON 5000**

**NONCON OPERATION**

Facility connects to the “NONCON” reactor via flange or in the case of larger projects, directly into a poured concrete channel. Water or wastewater enters a pressurized transition box and then feeds into a bank of transparent tubes. Water and wastewater travels through the tubes and exits into the discharge pressure box. Tubes are rated at 45 psi.

Systems are designed based on a peak flow rate, a UV transmission percentage (UVT%) and information related to the plant’s discharge permit. The number of tubes and associated UV lamps are based on the biological testing (bioassay) testing and computational fluid dynamic (CFD) modeling.

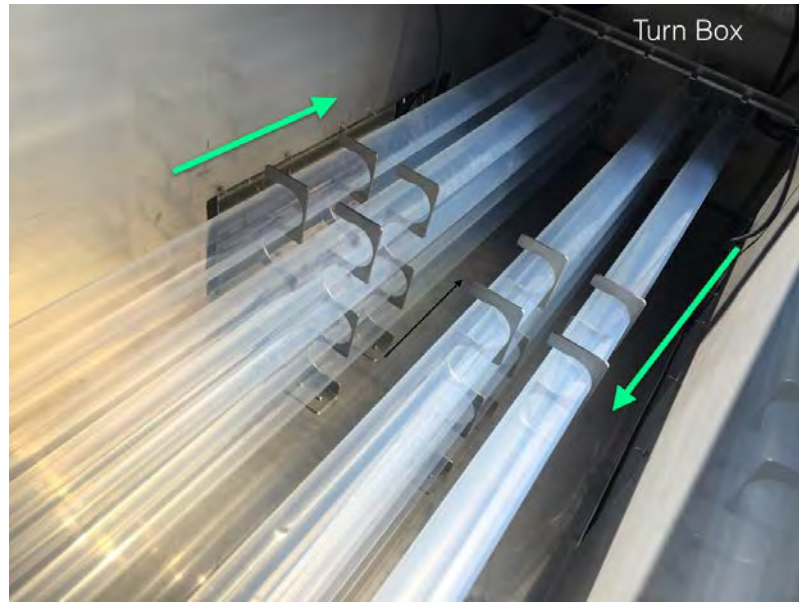

**NONCON OPERATION (SYSTEM CONTROLS AND REDUNDANCY)**

NONCON uses a remote Ballast Control Center (BCC). This stainless steel enclosure provides a single point of control for operators and removes sensitive components from reactor, which may be damaged in the event of moisture or flooding. The BCC houses ballasts, power controls, operating displays and UV monitor in a controlled environment. NONCON lamps (low-pressure high-output) are sensitive to temperature. To maintain optimal lamp temperature, reactor will be provided with a heat exchanger.

System has flexibility when designing for redundancy. Standalone, banks “in-series”, “U-turn” box (shown above) or in parallel. Unlike traditional open channel UV systems, the FEP tube systems have very low maintenance costs due to the lack of quartz sleeve fouling.

**NONCON 5000**





3020 Gore Road  
 London, Ontario N5V 4T7  
 1-888-220-6118  
 Tel: (519) 457-3400 / Fax: (519) 457-3030  
 www.trojanuv.com

**Trojan System UV3000™PTP  
 Municipal Wastewater Disinfection Equipment**

**Project Name: Lone Tree WWTP**

**Quote Number: Alt 2 for 0.822 MGD**

**Date: Sept 15, 2016**

<b>Prepared For:</b>	<b>Meredith Pearl</b>	<b>Phone:</b>	
<b>Company:</b>	<b>Veenstra &amp; Kimm</b>	<b>Fax:</b>	
		<b>Email:</b>	

UV SYSTEM DESIGN PARAMETERS		GUARANTEED PERFORMANCE	
Peak Design Flow	822,000 GPD	Validated UV Dose	> 31,000 uWs/cm <sup>2</sup>
UV Transmittance	65 %, minimum	Disinfection Limit	< 126 E. Coli/100 ml, based
TSS Concentration	30 mg/l, 30-day average		30 day geometric mean

**EQUIPMENT DETAILS D3300K**

- Two (2) complete UV systems supplied with Type 304 Stainless Steel Channel, Module Support Rack, Level Control Weir, Transition Boxes, Monitoring System, Spare Parts Package, Operators Kit and Maintenance Rack.
- 6 Type 316 Stainless Steel Modules per bank supplied, containing 2 UV lamps each – Total of 24 UV lamps
- Each UV module weighs 30 lbs (14 kg) and is easily handled by one person
- Each UV module has a standard 120V plug and 10 foot weatherproof cable for connection to GFI receptacle
- 6 Outdoor-rated GFI Power Distribution Receptacles supplied (one for 2 modules)
- Each lamp consumes 87.5 Watts – Total system power requirement of 2100 Watts 19.02 amps
- Lamp on/off status indicated on each UV module using LED indicators
- Monitoring System provided for local indication of UV intensity, lamp age and alarms
- Remote indication of UV intensity and low UV intensity alarm available
- Monitoring System requires 120V, single phase, 2 wire plus ground, 5 amp power supply
- Please refer to the enclosed drawings and specifications for full design details and requirements

**COMMERCIAL DETAILS**

- Comprehensive Lamp Warranty: Full replacement (non pro-rated) up to 12,000 hours or thirty-six (36) calendar months from shipment, whichever comes first
- System Warranty: 12 months after start-up or 18 months after shipment, whichever occurs first
- 3 Copies of Shop Drawings and O&M Manuals will be supplied
- Equipment Delivered 3-5 weeks after release for fabrication (approved shop drawings)
- Prices do not include any duties or taxes that may be applicable
- Prices are FOB factory, freight paid to jobsite
- Start-up and Training provided by Trojan-certified local service provider

**SELLING PRICE \$**

Please contact me if you have any questions about this design. I look forward to working with you on this project.

Rep Name:	Marci Whitaker	Phone:	515-979-4648
Rep Company:	MC2, Inc.	Fax:	
Email:	marci@mc2h2o.com		

Additional Information:



3020 Gore Road  
London, Ontario N5V 4T7  
1-888-220-6118  
Tel: (519) 457-3400 / Fax: (519) 457-3030  
www.trojanuv.com

**Trojan System UV3000™PTP  
Municipal Wastewater Disinfection Equipment**

**Project Name: Lone Tree IA WWTP**

**Quote Number: 080516**

**Date: August 5, 2016**

<b>Prepared For:</b>	<b>Meredith Pearl</b>	<b>Phone:</b>	
<b>Company:</b>	<b>V&amp;K</b>	<b>Fax:</b>	
		<b>Email:</b>	

<b>UV SYSTEM DESIGN PARAMETERS</b>		<b>GUARANTEED PERFORMANCE</b>	
Peak Design Flow	2,224,000 GPD	Validated UV Dose	> 31,000 uWs/cm <sup>2</sup>
UV Transmittance	60 %, minimum	Disinfection Limit	< 630 E. Coli/100 ml, based
TSS Concentration	30 mg/l, 30-day average		30 day geometric mean

**EQUIPMENT DETAILS            D3001M-1**

- Two (2) complete UV systems supplied with UV Modules, Module Support Rack, Level Control Weir, Monitoring System, Spare Parts Package and Operators Kit.
- UV system to be installed in a concrete channel (by others) as shown on enclosed drawings.
- 10 Type 316 Stainless Steel Modules per bank supplied, containing 4 UV lamps each – Total of 80 UV lamps
- Each UV module weighs 38 lbs (17 kg) and is easily handled by one person
- Each UV module has a standard 120V plug and 10 foot weatherproof cable for connection to GFI receptacle
- 10 Outdoor-rated GFI Power Distribution Receptacles supplied (one for 2 modules)
- Each lamp consumes 87.5 Watts – Total system power requirement of 7000 Watts (63.4 amps)
- Lamp on/off status indicated on each UV module using LED indicators
- Monitoring System provided for local indication of UV intensity, lamp age and alarms
- Remote indication of UV intensity and low UV intensity alarm available
- Monitoring System requires 120V, single phase, 2 wire plus ground, 5 amp power supply
- Please refer to the enclosed drawings and specifications for full design details and requirements

**COMMERCIAL DETAILS**

- Comprehensive Lamp Warranty: Full replacement (non pro-rated) up to 12,000 hours thirty-six (36) calendar months from shipment, whichever comes first
- System Warranty: 12 months after start-up or 18 months after shipment, whichever occurs first
- 3 Copies of Shop Drawings and O&M Manuals will be supplied
- Equipment Delivered 3-5 weeks after release for fabrication (approved shop drawings)
- Prices do not include any duties or taxes that may be applicable
- Prices are FOB factory, freight paid to jobsite
- Start-up and Training provided by Trojan-certified local service provider

**SELLING PRICE                                \$**

Please contact me if you have any questions about this design. I look forward to working with you on this project.

Rep Name:	Marci Whitaker	Phone:	
Rep Company:	Mc2, Inc.	Fax:	
Email:	marci@mc2h2o.com		

Additional Information:

## APPENDIX C - PRELIMINARY TREATMENT PROPOSALS

STAIR SCREEN (VULCAN)  
SPIRAL SCREEN (PARKSON)  
GRIT REMOVAL (HYDRO INTERNATIONAL)

**From:** [Matt Streeter](#)  
**To:** [Meredith Pearl](#)  
**Subject:** Lone Tree, IA WWTP (1512)  
**Date:** Monday, July 25, 2016 3:32:36 PM  
**Attachments:** [LONE TREE, IA - ESR 28 & EWP 250-600.dwg](#)  
[LONE TREE, IA - ESR 28 & EWP 250-600.pdf](#)

---

Meredith:

Budget price for one (1) ESR-28 Stair Screen (to fit a 2' wide x 6' deep channel) and one (1) EWP 250/600 Washing Press. Price includes 304 s.s. construction, 1/8" bar spacing, washing press inlet hopper and discharge piping, timer with ultra sonics, xp-proof motors, NEMA 7 local controls, NEMA 4X main controls, freight and start up. Prelim layout drawing is attached. The recommended 2' channel width is the narrowest available for this model of screen. We would recommend that the bottom of the channel be "profiled" with grouted fillets as shown on the drawing.

Please let me know if you have any questions. Thanks.

Matt

---

**From:** Matt Streeter [<mailto:mstreeter@e-equipmentsolutions.com>]  
**Sent:** Friday, July 22, 2016 1:45 PM  
**To:** Kyle Wilhelm; Norm Jackman; Brian Dieke  
**Subject:** Lone Tree, IA WWTP (1512)

Please provide a budgetary design and sales drawing for the following:

Q ave. = 0.176 mgd  
Q peak = 0.82 mgd  
Stair Screen & wash press  
Channel depth = 6-feet  
Channel Width = Please recommend  
Spacing = 1/8-inch  
Facility plan stage, so no water elevations

V&K, Coralville office is the Engineer.

Please let me know if you have any questions. Thanks.



Matthew D. Streeter, P.E. | Engineered Equipment Solutions  
203 E. Main St. | P.O. Box 541 | State Center, IA 50247  
Ph. [641-483-2904](tel:641-483-2904) | Fax [888-421-2856](tel:888-421-2856) | Cell [515-450-8803](tel:515-450-8803)  
[mstreeter@e-equipmentsolutions.com](mailto:mstreeter@e-equipmentsolutions.com)  
[www.e-equipmentsolutions.com](http://www.e-equipmentsolutions.com)



212 SOUTH KIRLIN STREET  
 MISSOURI VALLEY, IA. 51555  
 712-642-2755  
 www.vulcanindustries.com

SCALE: 1/4"=1'-0"	PRODUCT: ESR 28 STAIR SCREEN & EWP 250 WASHING PRESS	DRAWN BY: KMW
DATE: 7/25/16		REVISED BY:
CUST:		REVISED:
ENG:		
PROJECT: LONE TREE, IA.		DRAWING NO: VI-ESR-L1

**PRELIMINARY**

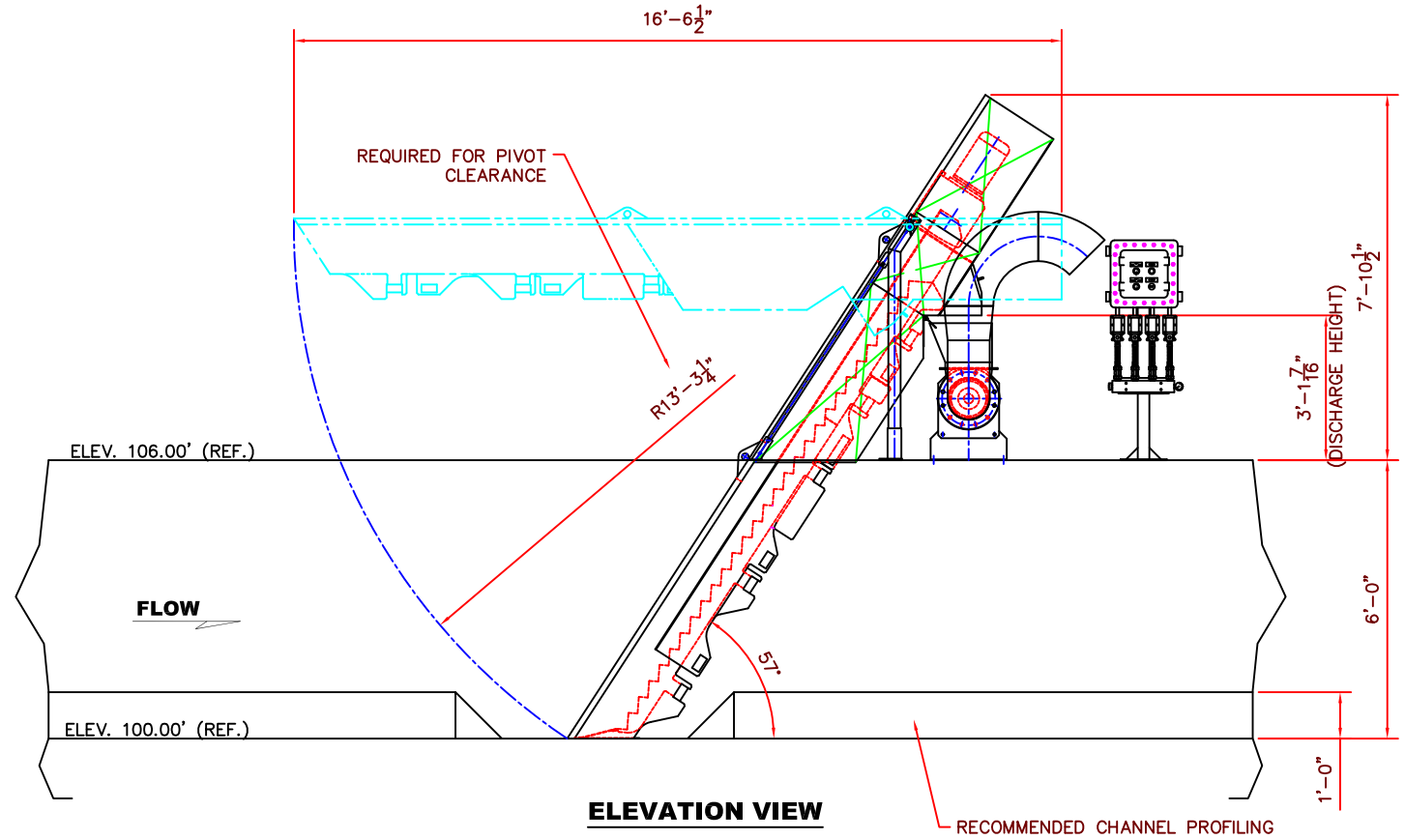
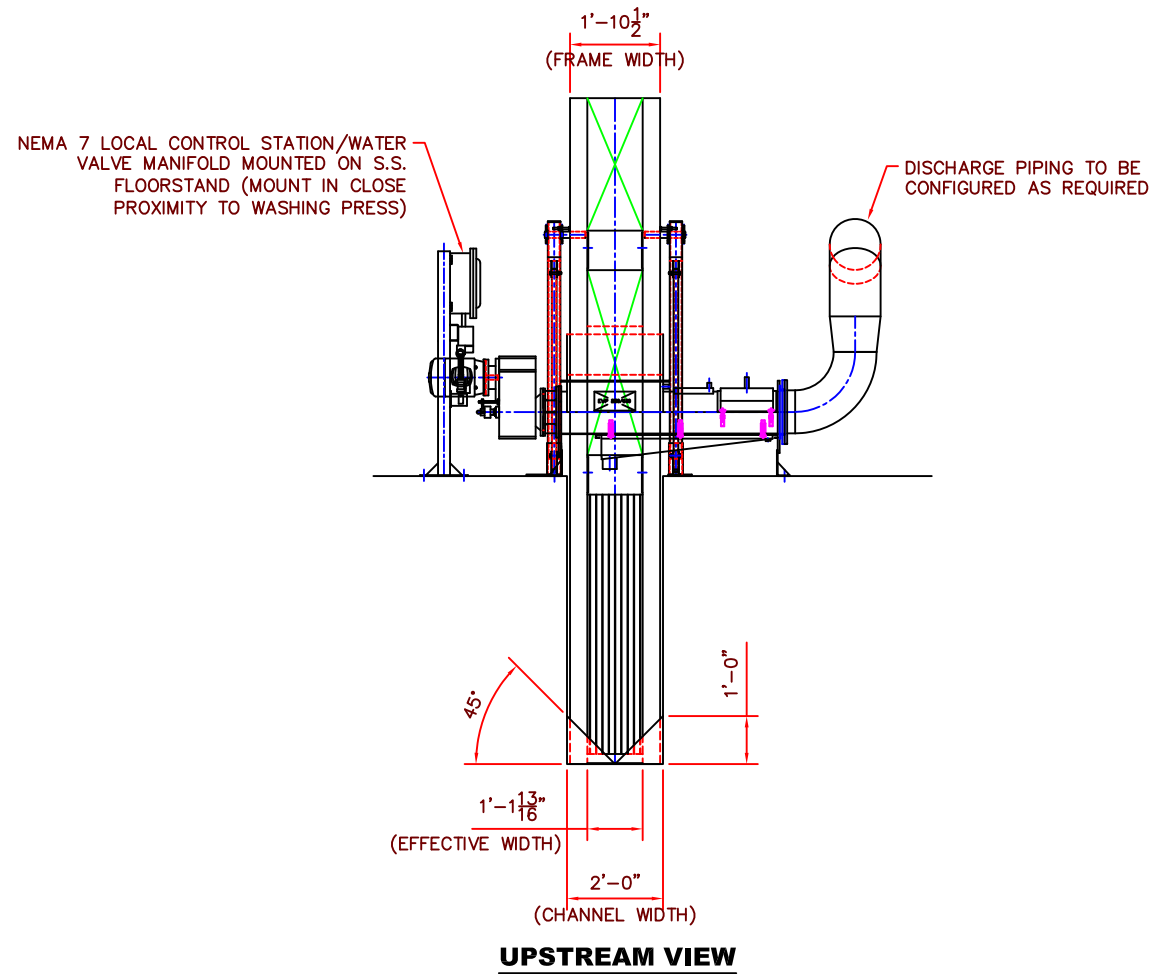
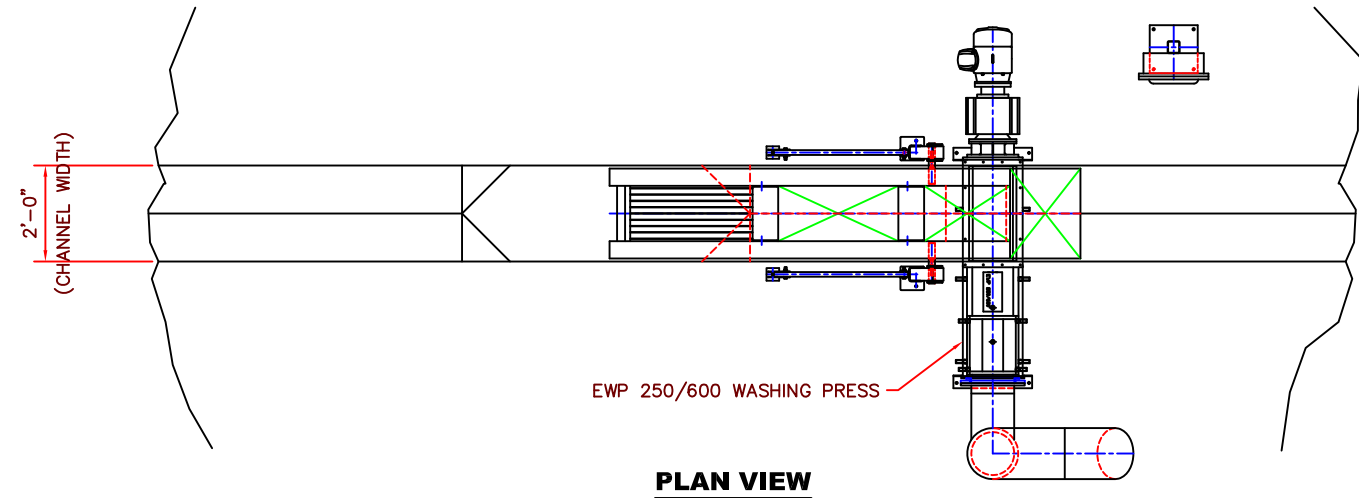

**From:** [Marci Whitaker](#)  
**To:** [Meredith Pearl](#)  
**Subject:** Lone Tree IA - revised Parkson screen quote  
**Date:** Monday, September 19, 2016 9:51:49 AM  
**Attachments:** [Helisieve-Fine-Screen.pdf](#)  
[HLS300\\_0304.dwg](#)  
[HLS300\\_0304.pdf](#)  
[HLS300\\_Spec\\_01\\_2014.doc](#)  
[hls300\\_hydraulic\\_data.pdf](#)  
[HLS-HLSP\\_gen.doc](#)  
[bagger\\_Brochure.pdf](#)

---

Meredith-

Attached is a drawing and information for the Helisieve HLS300 with 1/4" openings. Estimated price for the Helisieve unit model HLS300 per the attached drawing is \_\_\_\_\_. Hydraulic data and a spec are attached also. Parkson uses a heavy carbon steel screw for strength and longevity and the brush is also replaced in one piece. They transport tube openings and spiral diameter are also sufficiently sized to convey all solids. Some manufacturers will neck these down to reduce cost. The heaviest item is the spiral and you can easily compare these between manufacturers.

The screenings are dewatered as they go up into the screw. There is washwater attached but as long as the building does not freeze, this should be OK. There are options for heat tracing etc if needed. Washwater rate is 7 gpm (intermittent use) as described in spec. They can discharge into a container or get a bagging attachment. That can be added later if they find they want it. I'd need to check on more recent pricing but it's probably in the range of \$2,500 for that.

We have one at Prairie City that they could go see if they wanted to. The overall installation list is the HLS-HSP attachment.

Thank you,

Marci Whitaker, P.E.  
Mc<sup>2</sup>, Inc.  
Des Moines, Iowa  
(515) 979-4648  
[www.mc2h2o.com](http://www.mc2h2o.com)



This email has been checked for viruses by Avast antivirus software.  
[www.avast.com](http://www.avast.com)



# Hycor® Helisieve® In-Channel Fine Screen

## Model HLS

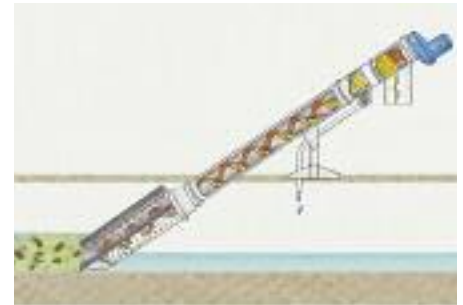

*Combines screening, conveying and dewatering into one reliable, automatic, cost-efficient system.*

### All-in-one screening, conveying and dewatering system

The Helisieve® system uses shaftless spiral technology to perform screening, solids conveying and dewatering in one cost efficient operation. The heart of the system is a heavy-duty carbon steel spiral that conveys screenings to the dewatering zone and dewateres them to acceptable landfill requirements. The spiral is fabricated in a continuous flight to assure a strong, stable structure. It is surrounded by a stainless steel tube that encloses screenings, minimizes odors and provides clean, hygienic operation.

The Helisieve system's shaftless core handles a greater volume of solids than shafted screw designs. Fibrous and bulky solids have a clear, barrier-free path to the dewatering zone. The shaftless design also eliminates the need for maintenance-intensive bottom support bearings and intermediate hanger bearings.

### The Helisieve® system performs three operations in one:

#### Screening

Influent moves into the fine screening area where the perforated screen removes solids. A spiral-mounted brush keeps the screen surface clean.

#### Conveying

The spiral moves the screenings upward through the transport area. There is no shaft to restrict flow or become entangled with long, stringy solids.

#### Dewatering

Solids are dewatered by compression against a plug of material formed in the flightless zone. Liquid is discharged through a perforated screen. A removable drain box simplifies access to the screen and solids plug. Solids at 40% dry weight are common.



*Durable spiral brush keeps the screen clean.*



*Close-up view of the new drain box with optional explosion-proof wiring.*

# Put Helisieve® System Shaftless Spiral Technology to work for you



- Compact and easy to install – shipped assembled, with flexible seals, for quick channel positioning, or in its own tank housing.
  - Economical – one low horsepower gearmotor drives the entire system.
  - Up-front serviceability – pivots out for easy access for above-channel maintenance.
  - Low maintenance – no troublesome submerged end bearings or intermediate hanger bearings.
- Cost-effective – integrates three processes: screening, conveying and dewatering, in one compact unit.
  - Efficient – the shaftless spiral provides greater conveying capacity and eliminates entanglement of solids around a shaft.
  - Lowers disposal costs – dewatering reduces weight and volume. Forty percent dry weight solids are common.
  - Hygienic – screens are enclosed by the stainless steel tube and can be discharged directly into sealed containers to minimize odor and handling. Optional bagger assemblies simplify disposal.
  - Designed to last – rugged steel alloy spiral fabricated in a continuous flight to tight manufacturing tolerances.



Shown with optional heat jacket.

## Screen openings

0.125" and 0.250" (6 mm) diameter and .040" x .4" perforated slots. Other opening sizes are possible.

## Helisieve Plus® in-tank system for pumped flows

Screens, conveys and dewaterers like the Helisieve unit, but is self-contained in a stainless steel tank. Suitable for industrial and municipal processes.



Fort Lauderdale

Chicago

Montreal

Dubai

ISO 9001:2008 Certified  
Quality Management System

[www.parkson.com](http://www.parkson.com)  
[technology@parkson.com](mailto:technology@parkson.com)

1.888.PARKSON  
1.954.974.6610

AN AXEL JOHNSON INC. COMPANY



SCFC-HLS111909 ©2009 Parkson Corporation



## Proposal Package

### Grit Removal System

Lone Tree, IA WWTP

Engineer: Veenstra & Kimm, Inc.

Representative: Engineered Equipment Solutions

Manufacturer: Hydro International

2925 NW Aloclek Suite 140 · Hillsboro, OR 97124  
(503) 615-8130 ph · (503) 615-2906 fax · [www.hydro-int.com](http://www.hydro-int.com)



**Water & Wastewater Solutions**  
Grit Removal at its Finest...®

August 1, 2016

Ms. Meredith Pearl  
Veenstra & Kimm, Inc.  
860 22<sup>nd</sup> Avenue #4  
Coralville, IA 52241

**RE:** Headworks Grit Control & Dewatering System  
Lone Tree, IA WWTP  
File #16\_11\_0048-A

Dear Ms. Pearl:

Thank you for your interest in Hydro International. We are pleased to present our proposal for a Grit King<sup>®</sup> Grit Removal, and Dewatering System. Hydro International is dedicated to providing innovative, high performance grit removal equipment through superior engineering, high-quality products and unmatched customer service. Our extensive experience includes thousands of installations throughout the world.

Grit is continually introduced into collection systems, but is not uniformly carried to treatment facilities. As flows increase, the grit load entering the plant elevates. Once in the treatment plant, where velocities are slower than in the collection system, grit will deposit in processes, disrupting systems, decreasing equipment longevity, and increasing maintenance costs. The Grit King<sup>®</sup> Grit Removal System offers many benefits over conventional grit removal systems including:

- Removing fine grit protects equipment and processes from abrasive wear and sedimentation
- All-hydraulic design with no moving parts, minimizing operating and maintenance costs
- Small footprint system capable of high efficiency solids capture and removal
- Robust design allowing long component life with minimal wear
- Complete grit system with no weak link through capture to washing/classification to dewatering
- Minimal headloss at peak flows fits most existing flow profiles
- Structured flow ensures maximum retention time and full utilization of tank volume

We sincerely appreciate your interest in our equipment and look forward to working with you on this project. As you progress with the design, we can quickly generate CAD drawings, budget updates, and specifications as well as review equipment layouts and specifications for your particular application. Reference lists are available through your local representative. If you have any questions or concerns, do not hesitate to contact us.

Regards,  
Hydro International



**Lindsey Schweitzer**  
Sr. Applications Engineer

# Performance Objective

---

Hydro International is pleased to propose the following Grit King® grit removal and dewatering system to be installed in an existing plant/ which has flows of 0.178 mgd average and 0.82 mgd peak. Each component of the grit removal system is designed to remove 95% of all grit 150 or better at the component flows listed below.

## Proposed Equipment Summary

---

### Grit King® Grit Concentrator

The Grit King® is an all-hydraulic/non-mechanical vortex separator designed to remove grit, sediment and sand from wastewater, raw water and other liquids using vortex motion and boundary layer effects to aid gravitational settlement. The unit can be installed into the flow line, downstream of the screens, of any system where limited head is available. The unit requires no external power source, has no internal moving parts, is self-cleaning, has a compact modular construction and is virtually maintenance free.

---

Quantity:	1
Size:	6' diameter
Configuration:	In Situ
Performance:	95% removal of all grit (specific gravity 2.65) ≥ 150 microns @ peak flow
Performance:	95% removal of all grit (specific gravity 2.65) ≥ 75 microns @ average flow
Peak Flow/Unit:	0.82 mgd with 5" headloss
Average Flow/Unit:	0.178 mgd with 1" headloss
Depth of flow in Effluent channel @ Peak/Average:	7"/3"
Influent Connection:	8" plain end pipe
Effluent Connection:	18" circular outlet
Underflow Connection:	3"
Underflow Flow Rate/Unit:	75 gpm
NPW Connection:	1" NPT
NPW Requirement (for 2-4 min. every hour):	Intermittent 50 gpm @ 50 psig
Material of Construction:	304 SS Support Frame, Inlet Pipe, and Fluidizing Ring Cross-Linked Polyethylene Dip Plate, Center Shaft and Center Cone Precast Concrete Tank

### Decanter Dewatering Unit

The Decanter dewateres grit by quiescently settling high-density solids to retain all grit and abrasives. The Decanter is an economical option for smaller plants that require performance dewatering. The Decanter comes in three basic configurations to match local disposal trucks or equipment configurations: front-loading, rear-loading, and self-dumping.

---

Quantity:	1
Size:	1.5 cy

Overflow Connection: .....3" NPT  
 Drain Connection: .....2" NPT  
 Drain Screen: .....0.10" 304 SS wedgewire  
 Material of Construction: .....Galvanized Steel  
 Weight Dry/Wet (approximate): ..... 800/4,800 lbs

## Control Panel

The panel shall contain all timers, vfd, switches, and indicator lights to operate one (1) Grit King® unit and one (1) Grit Pump in either fully automated or manual mode.

---

Quantity: ..... 1  
 Enclosure Material: ..... 304 SS 1  
 Enclosure Type: ..... NEMA 12/4X/7  
 Power Supply: .....480V/3-phase  
 Control Logic: ..... Programmable Relay/PLC  
 Grit Pump Control: ..... VFD

## System Hydraulics

System hydraulics is the responsibility of the design engineer. Hydro International can provide information on Grit King® hydraulics and pumping and piping FAQ's to assist the engineer in determining system hydraulics and pump requirements, upon request.

## Design Recommendations

- 1/2" or finer screening prior to the grit removal system
- Velocity through bar screen openings/slots/apertures should not exceed 4 ft/s at peak flow as recommended by industry design manuals.
- Estimated grit load a peak flow 0.01 yd<sup>3</sup>/hr
- When there is high H<sub>2</sub>S in the influent, a coating on the precast concrete at the air/water interface is recommended.
- All piping connected to Hydro equipment must be supported by other means than the Hydro equipment.
- 2 – 3 ft/s channel velocities at peak flow as recommended by industry design manuals
- 4 – 7 ft/s grit slurry pipe velocities as recommended by industry design manuals
- Incorporate a drain line, piped to a floor drain, in the grit dumpster to allow for further dewatering prior to disposal
- A minimum 18" of access clearance around all equipment and minimum 3' of access clearance above equipment
- Operators find that it is useful to locate a spray hose adjacent to the equipment so that they can spray all equipment down during an inspection
- Incorporate a minimal access platform to facilitate inspection access to the top of the equipment
- Grit pumps may require NPW for seal flushing. Requirements for flushing are dependent on the make, model, and seal type of the pump specified by the engineer.

## Start-up

One (1) factory trained representative, two (2) trips, for start-up and instruction services as required totaling four (4) days.

**Quote Validity: 30 days**

## Exclusions

Any item(s) not specifically described above are excluded and are not to be supplied by Hydro International including but not limited to the following:

- Field assembly, erection and installation
- Anchor Bolts

- Interconnecting piping and valving not expressly stated above
- Pipe connections and fittings not expressly stated above
- All pipe supports, hangers and braces
- Controls, switches, control panels and instrumentation of any kind not expressly stated above
- Wiring and conduit
- Grit pump(s)
- Field or touch-up paint, painting, blasting and touch-up of surface finish
- Spare parts not specifically stated above
- Unloading, hauling and storage charge
- Lubricating oil and greases
- Grit study, field performance testing, laboratory testing and sample collection and analysis
- All concrete and grouting work
- Insulation and heat tracing of any kind
- Seismic analysis
- Performance and/or Supply Bond(s)
- Grit dumpsters
- Translation Services

## Options

Quotes will be provided upon request for the following optional features:

- Stainless steel valve bodies
- Additional field days for startup or training
- Explosion proof upgrade
- PLC Based Control Panel
- Upgrade 304 to 316 Stainless Steel
- Seismic Certification
- Additional Decanters
- Grit King® cover
- Self-Priming Grit Pump(s)
- Extended Warranty
- Service & maintenance contract
- Field performance testing, laboratory testing and sample collection and analysis
- Precast dry pit pump tank

## Warranty

Hydro International's Standard Warranty shall apply per the Terms and Conditions of Sale.

## Delivery

Please allow 4 to 6 weeks after receipt of purchase order for approval drawings. Shipment is typically a maximum of 16 weeks after receipt of "Approved" or "Approved As Noted, Resubmittal Not Required" submittal package. Price includes truck freight to jobsite, but does not include any state or local taxes if required.

## Terms & Conditions

This proposal is made pursuant to Hydro International's standard Terms & Conditions of Sale, attached hereto and made a part hereof.

## Contacts

### Local Representative:

Mr. Matt Streeter  
 Engineered Equipment Solutions  
 203 E. Main Street  
 State Center, IA 50247  
 Ph: (641) 483-2904  
 Fx: (888) 421-2856  
 mstreeter@e-equipmentsolutions.com

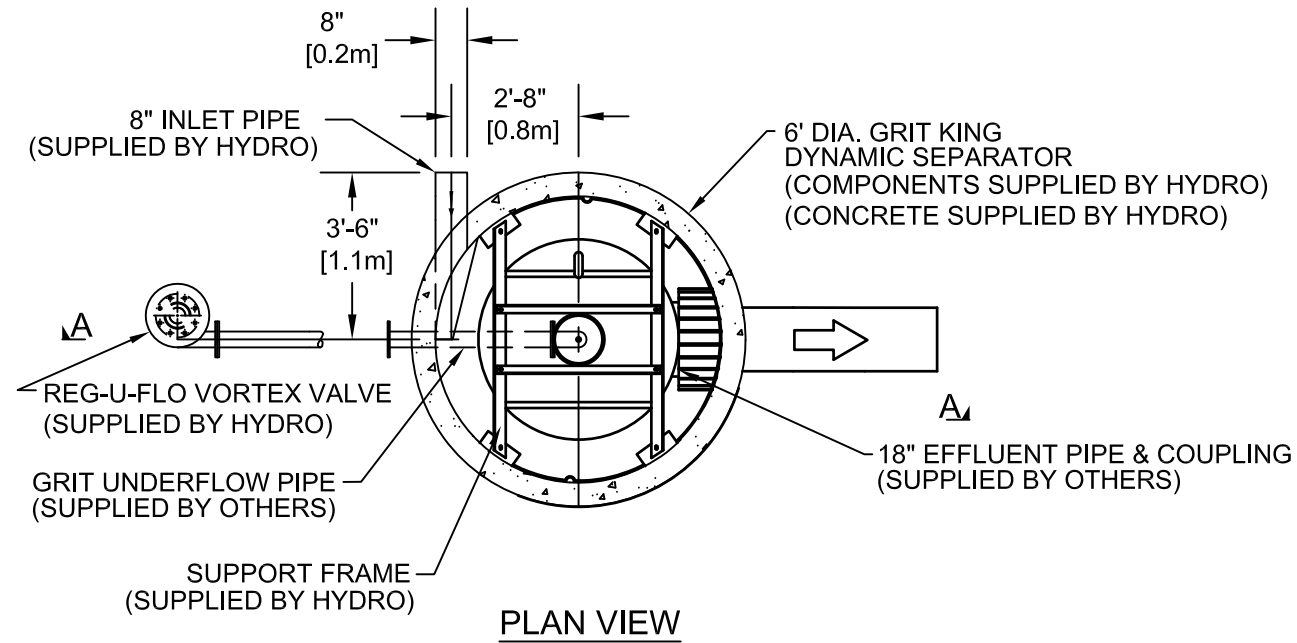

**ALTERNATE CONFIGURATIONS**

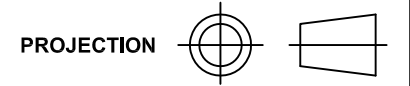
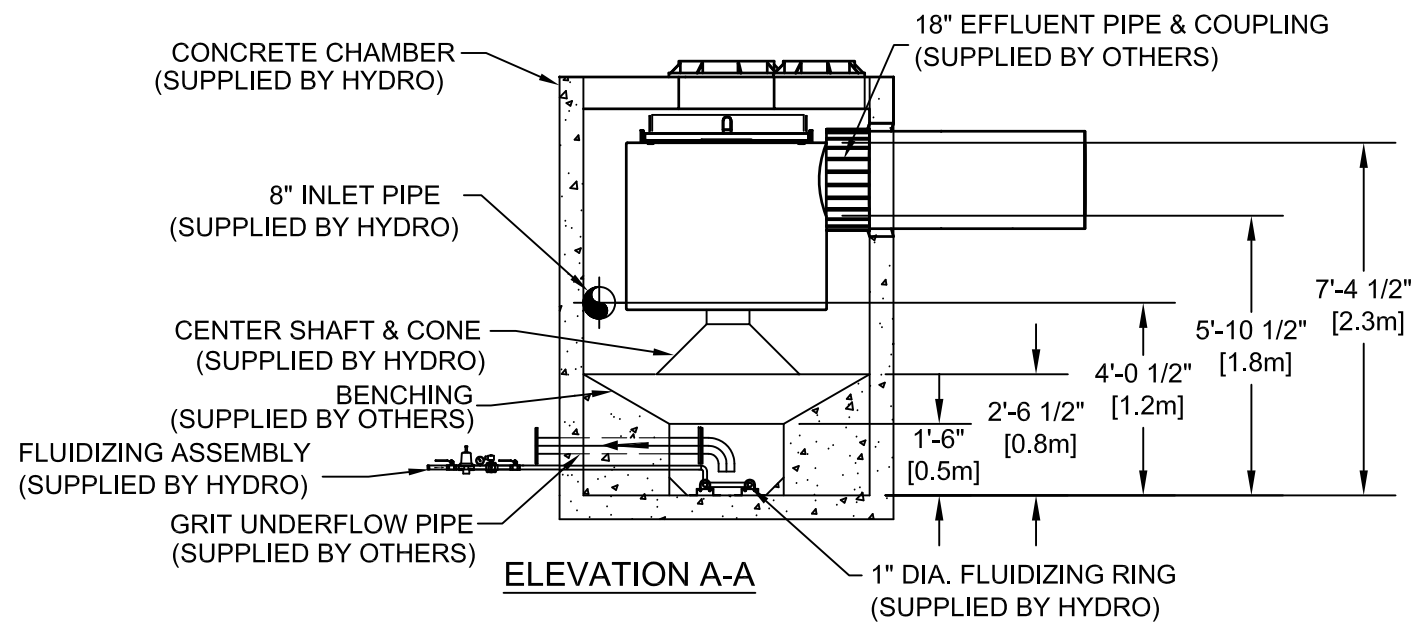
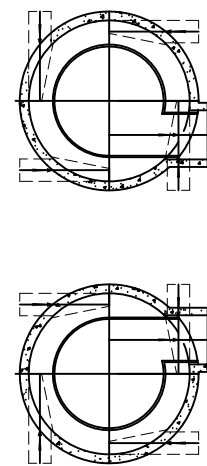

- NOTES:
1. PLANT FLOW BYPASS IS RECOMMENDED TO ALLOW THE GRIT KING TO BE TAKEN OUT OF SERVICE IF MAINTENANCE IS REQUIRED.
  2. THE INLET PIPE AND OVERFLOW CHANNEL MAY BE ROTATED 360 DEGREES ABOUT THE UNIT'S CENTRAL AXIS BUT INLET AND OUTLET ORIENTATION MUST REMAIN THE SAME.
  3. CLOCKWISE AND COUNTERCLOCKWISE CONFIGURATIONS ARE AVAILABLE
  4. THE INLET PIPE DIAMETER VARIES BASED ON THE DESIGN FLOW RATE AND HEADLOSS REQUIREMENTS.
  5. ALTERNATE INLET AND EFFLUENT CONFIGURATIONS ARE AVAILABLE.
  6. FLUIDIZING WATER REQUIREMENTS  
50 gpm [2.3 l/s] @ 50 psi [345 Kpa]
  7. THE OVERALL ELEVATIONS CAN VARY BASED ON THE SITE CONDITIONS
  8. DRY PIT PUMP ARRANGEMENTS ARE AVAILABLE. SUBMERSIBLE PUMP ARRANGEMENTS ARE AVAILABLE FOR UNITS 9' DIAMETER AND LARGER.
  9. THE GRIT PUMP SUCTION LINE SHOULD BE DESIGNED FOR A 4-7 FT/S [1.2-2.2 m/s] LINE VELOCITY.

REV	BY	DATE	DESCRIPTION
<b>REVISION HISTORY</b>			
Date	02/19/13		Scale 1/4"=1'0"
Drawn By	Checked By	Approved By	
LS	-	-	

Title  
**GRIT KING SEPARATOR**  
**6' DIAMETER**  
**IN-SITU**  
**PROPOSAL DRAWING**



2925 NW Aloclek Drive  
 Suite 140  
 Hillsboro, OR 97124  
 Tel: (503) 615-8130  
 Fax: (503) 615-2906  
 email: sales@eutek.com

ANY WARRANTY GIVEN BY HYDRO INTERNATIONAL WILL APPLY ONLY TO THOSE ITEMS SUPPLIED BY IT. ACCORDINGLY HYDRO INTERNATIONAL CANNOT ACCEPT ANY RESPONSIBILITY FOR ANY STRUCTURE, PLANT, OR EQUIPMENT, (OR THE PERFORMANCE THERE OF) DESIGNED, BUILT, MANUFACTURED, OR SUPPLIED BY ANY THIRD PARTY. HYDRO INTERNATIONAL HAVE A POLICY OF CONTINUOUS DEVELOPMENT AND RESERVE THE RIGHT TO AMEND THE SPECIFICATION. HYDRO INTERNATIONAL CANNOT ACCEPT LIABILITY FOR PERFORMANCE OF ITS EQUIPMENT, (OR ANY PART THEREOF), IF THE EQUIPMENT IS SUBJECT TO CONDITIONS OUTSIDE ANY DESIGN SPECIFICATION. HYDRO INTERNATIONAL OWNS THE COPYRIGHT OF THIS DRAWING, WHICH IS SUPPLIED IN CONFIDENCE. IT MUST NOT BE USED FOR ANY PURPOSE OTHER THAN THAT FOR WHICH IT IS SUPPLIED AND MUST NOT BE REPRODUCED, IN WHOLE OR IN PART, WITHOUT PRIOR PERMISSION IN WRITING FROM HYDRO INTERNATIONAL.  
 ©2011 HYDRO INTERNATIONAL

**DO NOT SCALE DRAWING**  
 UNLESS OTHERWISE SPECIFIED, DIMENSIONS ARE IN INCHES. TOLERANCES ARE:  
 FRACTIONS ± 1/16  
 DECIMALS ± .06  
 ANGLES ± 1'

Approximate Weight:	-	Next Assembly:	-
Finish:	-	Ref. No.:	<b>PROPOSAL</b>
Treatment:	-	Drawing No.:	12-3248-01
Sheet Size:	B	Sheet:	1 OF 1
		Rev	-



1. 3" NPT OVERFLOW CONNECTION AND 2" NPT DRAIN CONNECTION IS SHOWN ON THE LEFT SIDE (SEE PLAN VIEW). PLEASE NOTE THAT THESE COMPONENTS CAN ALSO BE LOCATED ON THE RIGHT SIDE.

2. EQUIPMENT WEIGHT (LBS):  
 DRY: 800; WET: 4,800

3. SCREENINGS ARE NOT TO BE DUMPED INTO THE DECANTER.

 CONTRACTOR TO DIRECT FLOW TO AN OPEN DRAIN.

D	AP	121311	UPDATED SD
C	LS	10/10/11	PIPING & NOTES ADDED
B	SR	01/05/10	RE-ISSUE NEW BORDER
REV	BY	DATE	DESCRIPTION

**REVISION HISTORY**

Date	Scale
03/08/01	NTS

Drawn By	Checked By	Approved By
SAJ/MA	AN	

Title  
 1.5 cy DECANTERS

PROPOSAL DRAWING



2925 NW Aloclek Drive  
 Suite 140  
 Hillsboro, OR 97124  
 Tel: (503) 615-8130  
 Fax: (503) 615-2906  
 email: sales@eutek.com

Next Assembly:	N/A
Ref. No.	PROPOSAL
Drawing No.	S00006-002
Rev	D

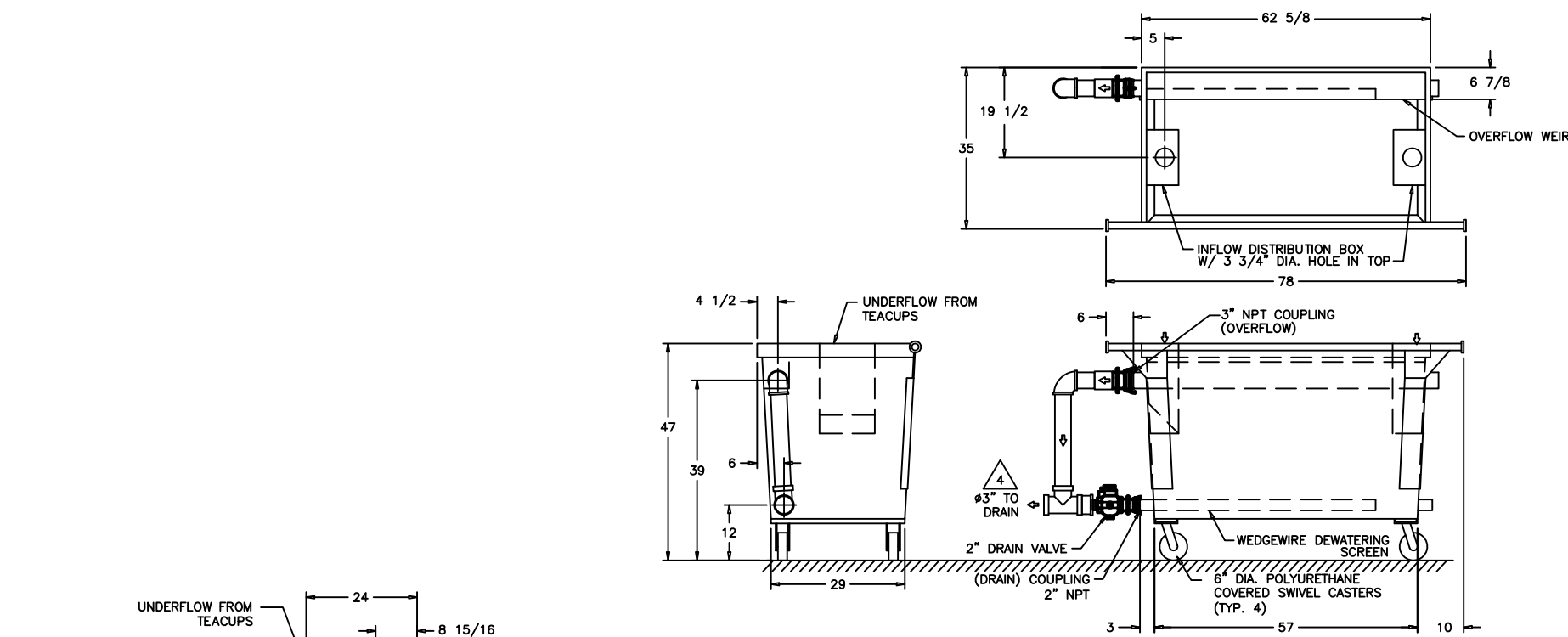

REAR LOADING DECANTER

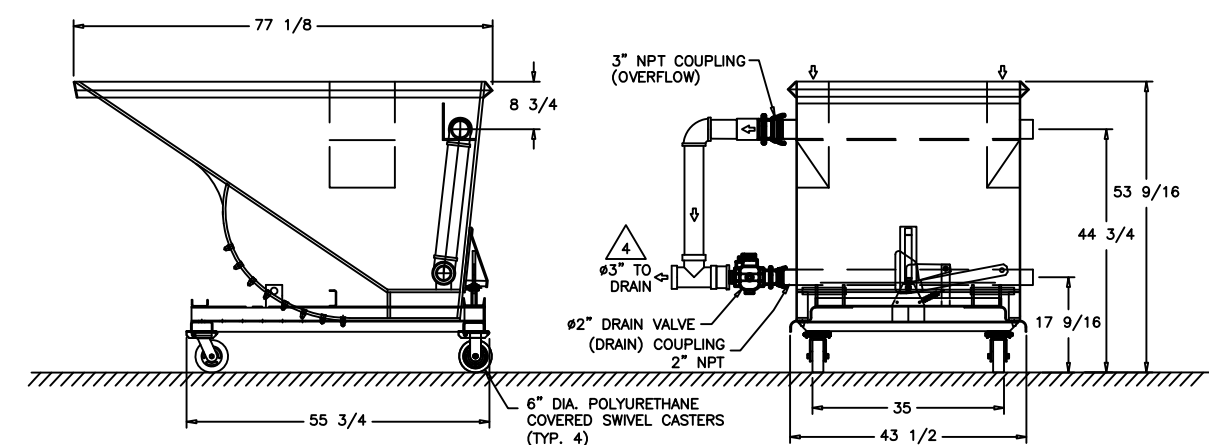
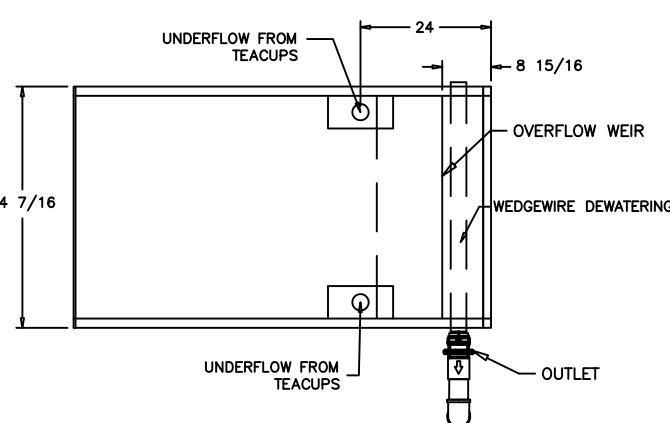

SELF-DUMPING DECANTER

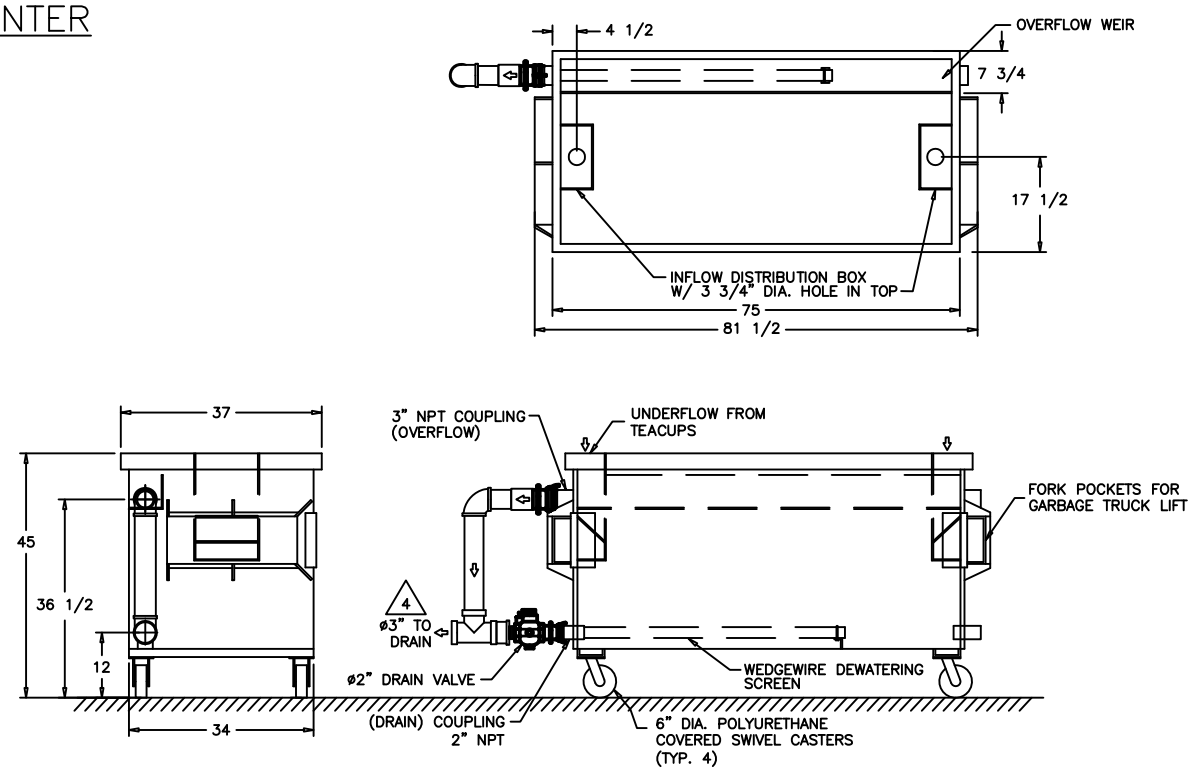

FRONT LOADING DECANTER

ANY WARRANTY GIVEN BY HYDRO INTERNATIONAL WILL APPLY ONLY TO THOSE ITEMS SUPPLIED BY IT. ACCORDINGLY HYDRO INTERNATIONAL CANNOT ACCEPT ANY RESPONSIBILITY FOR ANY STRUCTURE, PLANT, OR EQUIPMENT, (OR THE PERFORMANCE THERE OF) DESIGNED, BUILT, MANUFACTURED, OR SUPPLIED BY ANY THIRD PARTY. HYDRO INTERNATIONAL HAVE A POLICY OF CONTINUOUS DEVELOPMENT AND RESERVE THE RIGHT TO AMEND THE SPECIFICATION. HYDRO INTERNATIONAL CANNOT ACCEPT LIABILITY FOR PERFORMANCE OF ITS EQUIPMENT, (OR ANY PART THEREOF), IF THE EQUIPMENT IS SUBJECT TO CONDITIONS OUTSIDE ANY DESIGN SPECIFICATION. HYDRO INTERNATIONAL OWNS THE COPYRIGHT OF THIS DRAWING, WHICH IS SUPPLIED IN CONFIDENCE. IT MUST NOT BE USED FOR ANY PURPOSE OTHER THAN THAT FOR WHICH IT IS SUPPLIED AND MUST NOT BE REPRODUCED, IN WHOLE OR IN PART, WITHOUT PRIOR PERMISSION IN WRITING FROM HYDRO INTERNATIONAL.  
 ©2011 HYDRO INTERNATIONAL

**DO NOT SCALE DRAWING**

UNLESS OTHERWISE SPECIFIED, DIMENSIONS ARE IN INCHES. TOLERANCES ARE:  
 FRACTIONS ± 1/16  
 DECIMALS ± .06  
 ANGLES ± 1'

Approximate Weight:  
**SEE TABLE**

Finish:	
Treatment:	
Sheet Size:	B
Sheet:	1 OF 1

APPENDIX D - MECHANICAL TREATMENT PROPOSALS

SEQUENCING BATCH REACTOR (FLUIDYNE CORP.)

SEQUOX (AER-MOD, INC.)

**FLUIDYNE CORPORATION**  
5436 Nordic Drive, Suite D  
Cedar Falls, IA 50613  
Ph.: 319-266-9967  
Fax: 319-277-6034



**TO: Veenstra & Kimm**  
**ATTN: Meredith Pearl**

**From: Erick Mandt**  
**Date: July 29, 2016**

Relationships • Technology • Service  
4428 South 108th Street  
Omaha, NE 68137

**RE: Lone Tree, Iowa – Wastewater treatment plant**  
**Fluidyne ISAM™ system**

**(402) 551-7995**  
**(402) 553-5879 Fax**  
[www.bgagurney.com](http://www.bgagurney.com)

Ms. Pearl:

We have reviewed the design information for the above project.

We have designed a Fluidyne ISAM™ System based on the following data:

	<b>INFLUENT</b>	<b>MONTHLY AVERAGE DESIGN EFFLUENT</b>
ADF:	0.176 MGD	
AWW:	0.822 MGD	
MWW:	0.822 MGD	
Design BOD5:	360 lbs/day	< 25 mg/l
Design TSS:	472 lbs/day	< 30 mg/l
Design TKN:	78 lbs/day	< 1 mg/l NH3

We have assumed the wastewater is non toxic and readily biodegradable and the pH is close to 7 and sufficient alkalinity in the waste stream.

Please see the attached process design calculations showing tank and equipment sizing and power requirements based on the above data.

Internal Concrete Tank Dimensions are as follows:

ISAM: Each of two tanks at 33.5' X 20' X 18' TWL X 20' wall height (covered and vented)

SAM: Each of two tanks at 20' X 40' X 18' TWL X 20' wall height

SBR: Each of two tanks at 40' X 40' X 18' TWL X 20' wall height

Aerobic Sludge Storage: One tank at 12.5' X 20' X 18' TWL X 20' wall height

Alternate tank geometries to optimize tank layout and construction costs could be utilized.

Please see the drawings of the proposed equipment and layout. The system will be divided into three compartments. The first compartment is the ISAM™ tank.

This tank is used to remove solids and to store waste sludge from the aerobic process. The next tank is the SAM™ tank. This tank is used for flow equalization as well as anoxic mixing prior to the SBR. With the SAM™ tank an integral part of the process; we can operate in a true batch mode without affecting the process or the clarification stage.

Each SBR is equipped with an overflow weir. The overflow weir returns mixed liquor back to the SAM™ tank. This allows nitrate return for effective and rapid denitrification. The overflow weir also returns any scum that may be in the SBR back to the SAM™ tank. Therefore, before decanting, no scum or floatable solids are present in the SBR tank.

With the sludge reduction features of the ISAM™, our process calculations estimate that our design has approximately 240 days of sludge storage in the process. We anticipate the sludge will be in the 3 to 5% solids concentration.

We are proposing the Fluidyne jet aeration/mixing headers to provide oxygen to the system. Jets are highly efficient in dirty water applications with a designed alpha value of 0.9. Our decanter is a fixed style mounted to the wall with no submerged or moving parts. An air lock prevents solids from entering the decant during fill or react.

Fluidyne proposes the following:

### **ISAM™**

Two (2) ISAM™ Influent Diffusers  
Four (4) ISAM™ Overflow Assembly  
Six (6) ISAM™ Airlift Pumps with in-basin piping.

### **SAM™**

Four (4) SAM™ Tank Influent Diffusers  
Two (2) Sets of Level Sensors  
Two (2) Fluidyne model# FAS-10 SAM tank mixer/aspirators.  
Four (4) 10 HP Submersible SBR Feed Pump/Jet Motive Pumps with discharge elbow, guide rail brackets, power cord and lifting.  
Two (2) Waste Sludge Control Valves in vent valve box

### **SBR**

Four (4) Fluidyne model # DM2JA5 Jet Aeration Headers including all in-basin air and liquid piping, stainless steel supports and pneumatic backflush.  
Three (3) 15 HP Positive Displacement Blower Packages (one blower to be an in-line spare.  
Four (4) Fluidyne model # FOW-12 SBR Overflow weir/anoxic mix assembly

Four (4) Fluidyne model # SED-16 Solids Excluding Decanters including vent valve, siphon break and discharge control valve.

Two (2) Sets of Level Sensors.

Two (2) DO Probes

Two (2) TSS Probes

One (1) Multi-Channel Analyzer for DO and TSS measurement

### **AEROBIC SLUDGE STORAGE**

One (1) Sets of Level Sensors

One (1) Fluidyne model# FAS-10 Aerobic Sludge Storage tank mixer/aspirator.

Two (2) Telescoping supernatant return valve.

### **CONTROLS**

One (1) Control Panel with PLC, operator interface, switches, indicating lights and relays to automatically control the ISAM functions

The budgeted price for the above equipment is \$\_\_\_\_\_ USD FOB-factory with freight allowed to the Lone Tree, Iowa. Not included is any tankage, walkways, platforms, stairways, handrailing, grating, electrical or mechanical installation, out of basin or interconnecting piping, valving or supports, motor starters, remote panels, junction boxes; disconnects; field wiring and conduit, pre-treatment equipment, sludge handling equipment, interconnecting piping between blowers and in-basin equipment, disinfection equipment; sludge wasting discharge piping, chemical feed equipment or chemicals if required, tank spool pieces, interconnecting hardware or gaskets, anchor bolts, taxes duty or anything not specifically mentioned above.

We estimate a delivery time of 14 to 18 weeks after release to production.

The Fluidyne proposal offers numerous advantages including:

1. Control strategies based on varying aeration/mixing requirements depending on the strength of the incoming wastewater. This design minimizes operating costs and controls over/under aeration.
2. No need for automated influent control valves.
3. Built in scum skimming mechanism removes scum from SBR prior to decanting.
4. Energy efficient jet aeration equipment with high alpha values and oxygen transfer. Test data demonstrates alpha values of 0.9.

5. Jet aeration equipment will last 3 to 4 times as long as coarse or fine bubble diffusers. This results in less maintenance and operation costs.
6. Jets have large solids handling capability with minimum 1 1/2" solids handling. A built in backflush allows cleaning of the jet header without entering or draining the tank. Therefore plugging is not a concern compared to fine or coarse bubble diffusers.
7. The decanter has no moving parts in the basin that can freeze or malfunction.
8. Submerged aeration/mixing header provides multipoint mixing locations for energy efficient off-bottom solids suspension. The jet manifold provides anoxic mixing by not running the blower. This minimizes in-basin equipment, as a separate mixer is not required.
9. Integral Sludge Reduction technology.

Please let me know if you have any questions or need additional information.

Best regards,

A handwritten signature in black ink, appearing to read "Erick Mandt". The signature is fluid and cursive, with a prominent initial "E".

Erick Mandt

REVISIONS			
REV.	DESCRIPTION	DATE	APPROVED

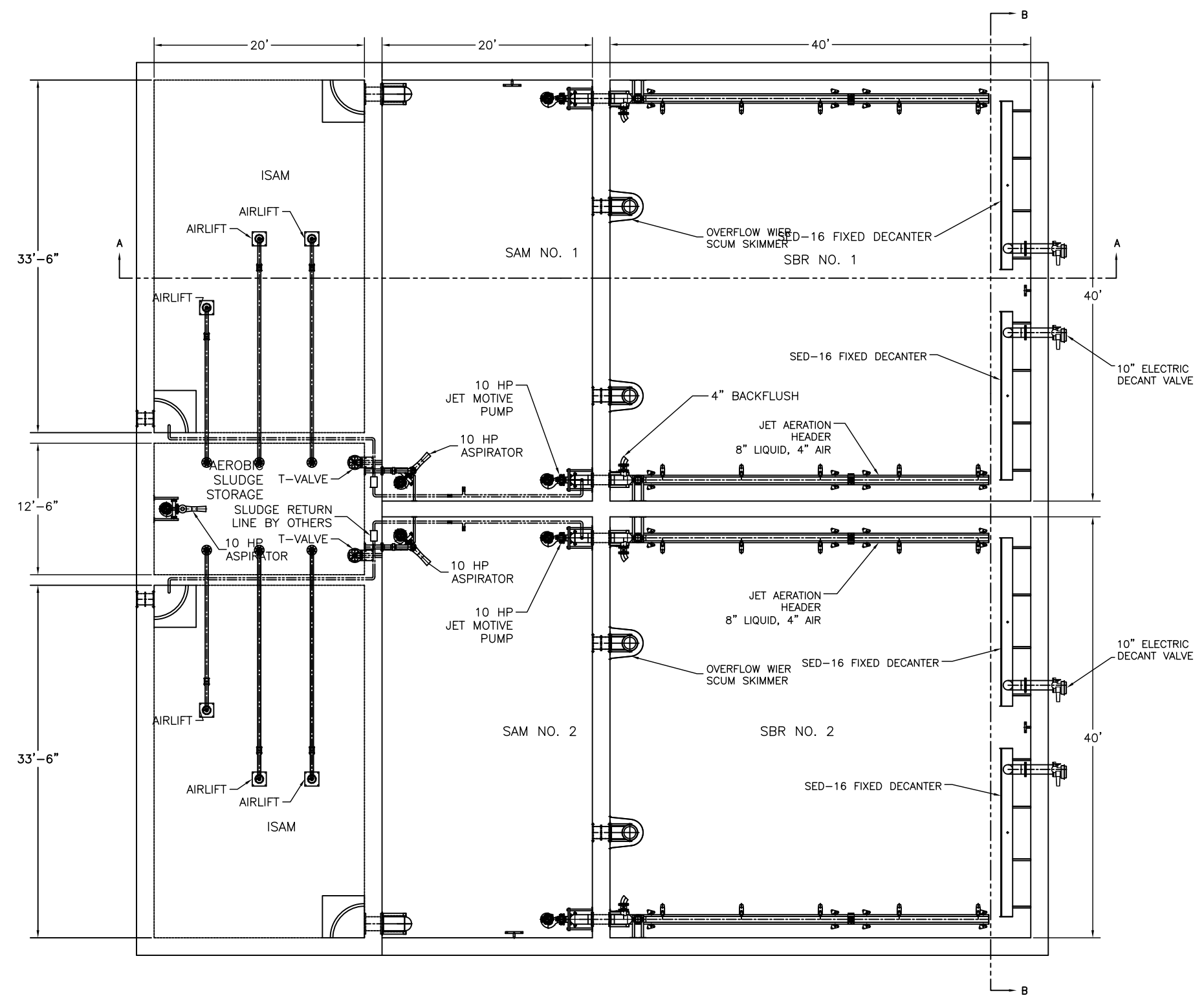

- NOTES:
1. THOROUGHLY REVIEW INSTALLATION INSTRUCTIONS PRIOR TO BEGINNING FIELD WORK. IF YOU HAVE ANY QUESTIONS PLEASE CONSULT FACTORY.
  2. ALL NOZZLES TO BE LEVELED AND AT THE SAME ELEVATION  $\pm 1/4"$ .
  3. (FJ) MAY REQUIRE CUT-TO-FIT OR ADDITIONAL PIPE FOR FIELD ADJUSTABILITY.
  4. SEE INSTALLATION INSTRUCTIONS FOR PROPER PREPARATION TO ENSURE PROPER FITTING OF ALL COMPONENTS BEFORE F.R.P. FIELD WELDING AND FIELD LAMINATING.
  5. ALL PUMP GUIDE RAILS BY OTHERS.
  6. FREEZE PROTECT ALL EXPOSED PIPING, FITTINGS AND VALVES.

This drawing and all appurtenant matter contains information proprietary to Fluidyne Corporation and is loaned subject to return upon demand and must not be reproduced, copied, loaned, revealed, nor used for any other purpose than that for which it is specifically furnished without expressed written consent of Fluidyne Corporation.



LONE TREE, IA - 1 - PLAN VIEW

DRAWN NWS	DATE 7/29/16	JOB #	CAD FILE Lone Tree, IA - 1 - Plan View
CHECKED	DATE	SCALE	SHEET 1 OF 2

REVISIONS			
REV.	DESCRIPTION	DATE	APPROVED

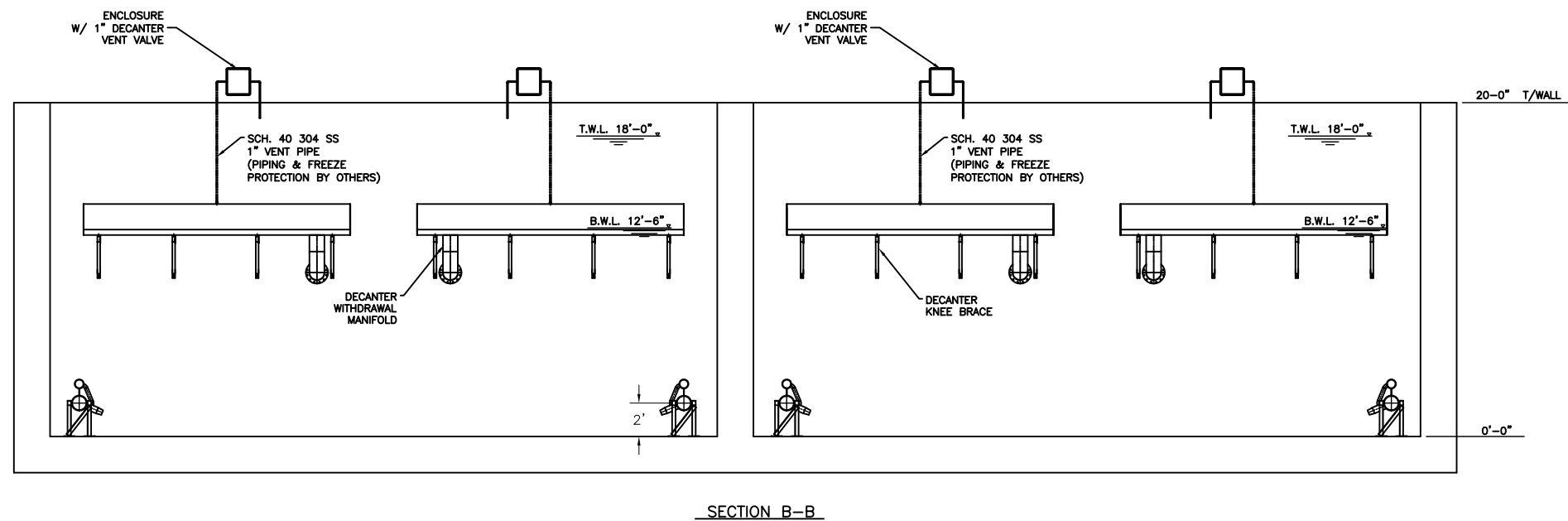
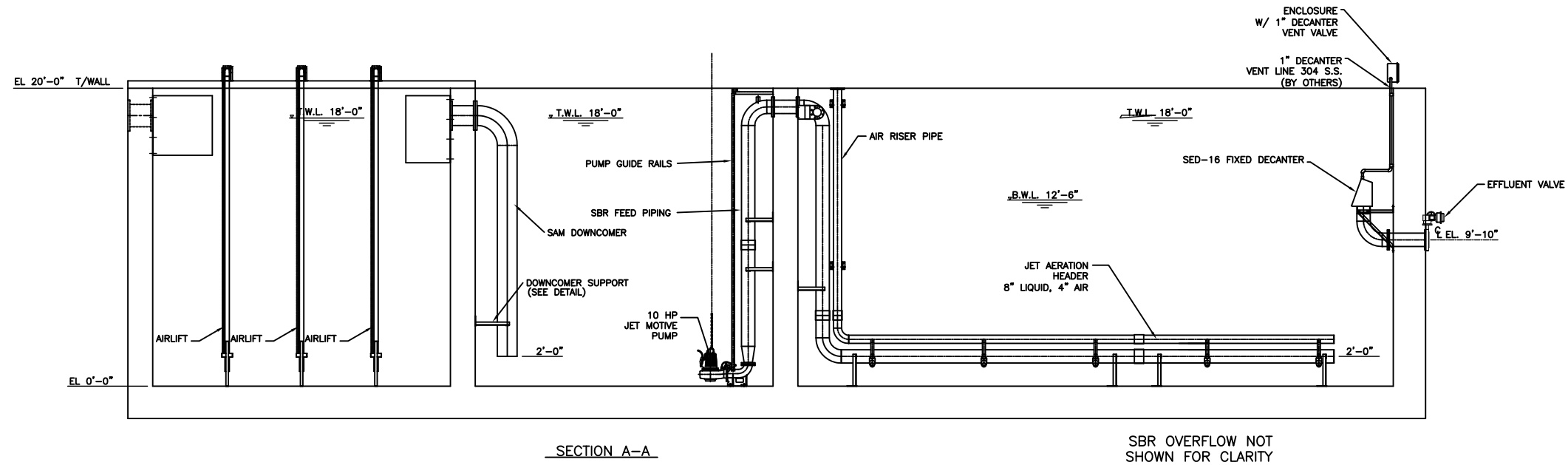

NOTES:

1. THOROUGHLY REVIEW INSTALLATION INSTRUCTIONS PRIOR TO BEGINNING FIELD WORK. IF YOU HAVE ANY QUESTIONS PLEASE CONSULT FACTORY.
2. ALL NOZZLES TO BE LEVELED AND AT THE SAME ELEVATION  $\pm 1/4"$ .
3. (FJ) MAY REQUIRE CUT-TO-FIT OR ADDITIONAL PIPE FOR FIELD ADJUSTABILITY.
4. SEE INSTALLATION INSTRUCTIONS FOR PROPER PREPARATION TO ENSURE PROPER FITTING OF ALL COMPONENTS BEFORE F.R.P. FIELD WELDING AND FIELD LAMINATING.
5. ALL PUMP GUIDE RAILS BY OTHERS.
6. FREEZE PROTECT ALL EXPOSED PIPING, FITTINGS AND VALVES.

This drawing and all appurtenant matter contains information proprietary to Fluidyne Corporation and is loaned subject to return upon demand and must not be reproduced, copied, loaned, revealed, nor used for any other purpose than that for which it is specifically furnished without expressed written consent of Fluidyne Corporation.



LONE TREE, IA - 2 - SECTION VIEWS

DRAWN NWS	DATE 7/29/16	JOB #	CAD FILE Lone Tree, IA - 2 - Section Views
CHECKED	DATE	SCALE	SHEET 2 OF 2



## ISAM™ CALCULATIONS

PROJECT: Lone Tree, IA ISAM™

ENGINEER: V &amp; K

PROJECT #: ISAM™

DATE &amp; TIME:

7/29/2016 13:07

	ISAM™ ADW Design	Current ISAM™ AWW Design
<b>INFLUENT CONDITIONS</b>		
Flow (m3/d)	666	3111
Flow (mgd)	0.176	0.822
Flow(gpm)	122	571
BOD (mg/l)	245	52
(lb/d)	360	360
TSS (mg/l)	322	69
(lb/d)	472	472
TKN (mg/l)	53	11
(lb/d)	78	78
<b>OXYGEN REQUIREMENTS</b>		
Pounds TKN required for synthesis	13	13
Pounds of NO3-N produced	65	65
Pounds O2 recovered/pound NO3-N reduced	2.6	2.6
Pound of Oxygen/ pound of BOD	1.4	1.4
Pound of Oxygen/pound of TKN	4.6	4.6
Actual Oxygen Demand (lb O2/d) Total	861	861
Alpha	0.85	0.85
Beta	0.95	0.95
Theta	1.024	1.024
Operating Dissolved oxygen (mg/l)	2	2
Clean Water oxygen sat. at op. temp (mg/l)	9.09	9.09
Clean Water oxygen sat. at std. temp (mg/l)	9.09	9.09
Clean water O2 sat, std temp, mid depth(mg/l)	11.50	11.50
Std. condition ambient pressure (psia)	14.7	14.7
Oper. condition ambient pressure (psia)	14.5	14.5
Wastewater temperature (c)	20	20
SOR/AOR ratio	1.54	1.54
Standard Oxygen Demand (lb O2/d) total	1328	1328
Standard Oxygen Demand (lb O2/hr)	111	111
Standard Oxygen Deman (lb O2/hr/tank)	55	55
Specific oxygenation rate (mg/l-hr)	31	31
Pounds of oxygen/pound of air	0.23	0.23
Clean water efficiency (%)	24	24
Pounds of air/cubic foot of air	0.075	0.075
Aeration hours per day	12.00	12.00
Air flow rate (scfm/tank)	223	223
Air pressure losses (lines and nozzle)	0.7	0.7
Maximum air pressure (psig)	7.63	7.63
Average air pressure (psig)	6.39	6.39
<b>NITRIFICATION/DENITRIFICATION</b>		
Required alkalinity for nitrification (mg/l)	317	68
Alkalinity recovered, denitrification (mg/l)	133	29
Net alkalinity required (mg/l)	184	39
Mixed liquor temperature, C	15	15
ML dissolved oxygen (mg/l)	1	1
Max. nitrifier growth rate, day-1	0.204	0.204
Minimum SRT required for nitrification, days	4.89	4.89
Actual SBR SRT, days	14.27	16.31
Total SRT, days	21.41	24.47

## PROJECT: Lone Tree, IA ISAM™

Kn, half velocity constant (mg/l)	0.40	0.40
Design growth rate for heterotrophs/nitrifiers	0.0701	0.0613
Projected effluent soluble NH3-N, mg/l	0.21	0.17
Specific utilization rate, lbs BOD5/lb mlvss	0.22	0.20
lbs. mlvss required for BOD & NH3 removal	1647	1777
mlvss (mg/l)	700	800
Tank volume req. for BOD & NH3 removal (MG)	0.28	0.27
Denitrification rate (g/g/day)	0.047	0.047
lbs mlvss required for denitrification	1386	1386
Tank volume required for NO3 removal (MG)	0.24	0.21
Total tank volume required (MG)	0.52	0.47

## SBR/SAM™ TANK CONFIGURATION

No. of SBR tanks	2	2
Length SBR (ft)	40	40
Length SAM™ (ft)	20	20
Width (ft)	40	40
Bottom water level (ft)	12.3	12.3
Top water level (ft)	18	18
No. Decanters/tank	2	2
SBR Tankage Volume @ TWL(MG)	0.4308	0.4308
HRT (hrs)	58.75	12.58
SAM™ Tankage Volume	0.215	0.215
HRT (hrs)	29.38	6.29
Total Tankage Volume @ TWL(MG)	0.65	0.65
Total HRT (hrs)	88.13	18.87

## CYCLE TIMES/CAPACITY CALCULATIONS

Total decant volume (cubic feet)	18,304	18,304
Total decant volume (gallons)	136,914	136,914
Decant volume per tank (gallons)	68,457	68,457
Number of cycles per day/tank	1.29	6.00
Total time per cycle (minutes)	1120	240
Fill rate (gpm)	1762	1762
Fill time (minutes) SBR	39	39
Feed rate (gpm)	122	571
Interact Period (minutes)	994	113
Settle period (minutes)	45	45
Decant fill (minutes)	0	0
Average decant rate (gpm/ft decanter)	100	100
Decanter length (feet)	16	16
Decanting time (minutes)	43	43
Decanting rate (gpm)	1600	1600
Maximum aeration period available (hours/day)	22.12	15.22

## EQUIPMENT SELECTION

Air flow per nozzle (scfm)	45	45
Number of nozzles required (per tank)	4.95	4.95
Number of nozzles provided (per tank)	10	10
Actual airflow per nozzle (scfm)	22.27	22.27
Blower capacity required (scfm)	223	223
Blower capacity provided (scfm)	225	225

## PROJECT: Lone Tree, IA ISAM™

## POWER CONSUMPTION CALCULATIONS

Pump efficiency	0.75	0.75
Blower efficiency	0.626	0.6
Pump horsepower, BHP/tank	14	14
Mixing BHP/MG	66	66
Blower horsepower, BHP/tank	11	11
Total horsepower, BHP/tank	25	25
Aeration BHP/MG	117	117
Total design equivalent horsepower, BHP	25	25

## SLUDGE PRODUCTION

Sludge Yield Factor	0.7	0.7
Net Sludge Yield (lbs/d)	252	252
Sludge Concentration (%) from SBR	0.10	0.11
Sludge Wasting Rate (gpd)	30184	26411
Waste Sludge /cycle (gal)	11740	2200
WAS Pumping Rate (gpm)	75	75
Waste Sludge Cycle Time (min)	156.5	29.3
Thickened Sludge Concentration (%)	3	3
Thickened Sludge (gpd)	1006	1006
MLSS (mg/l) @ TWL	1000	1143
Sludge inventory total (lbs)	5390	6160
Sludge inventory in SBR (lbs)	3593	4107
SRT ( 1/days )	21.41	24.47

F/M	0.07	0.06
SVI (ml/g)	150	150
Sludge blanket level (ft)	2.70	3.09
Organic loading (lbs BOD/1000 ft3)	4.16	4.16

## ISAM™

Surface Area Required	293	1265
Number of tanks	2	2
Length required (ft) total both tanks	8.76	37.75
Length (ft) provided each tank	20.00	20.00
Width (ft)	33.5	33.5
TWL (ft)	18	18
Total volume (gal) available	180,418	180,418
Days sludge storage available undigested	179	179
Total sludge age including SBR (days)	194	196
Pounds sludge destroyed	166	166
% sludge reduction	66	66
Thickened, digested sludge (gpd)	342	342
Inerts accumulation (gal/d)	189	189
Days sludge storage available after digestion	187	187

## AEROBIC SLUDGE STORAGE TANK

Number of Tanks	1	1
Length (ft)	20	20
Width (ft)	12	12
TWL (ft)	18	18
Volume (gal)	32314	32314
Days sludge storage	61	61

**Aero-Mod, Inc.**  
**ACTIVATED SLUDGE DESIGN CALCULATIONS**

**Project:** Lone Tree, IA  
**Engineer:** Veenstra & Kimm, Inc.  
**Act. Sludge Process:** SEQUOX BNR

**Date:** 5-Aug-16  
**Units:** English

**DESIGN CONDITIONS & PARAMETERS**

	Influent	Clarifier Effluent		
Flow (Q), MGD	<b>0.822</b>		<b>Aeration Basin</b>	
BOD <sub>5</sub> , mg/l	<b>53</b>	<b>10.0</b>	Retention Time, hours	<b>6.0</b>
BOD <sub>5</sub> , lbs/day	360	68.6	Aeration Tank Volume, Mgal	0.207
BOD <sub>L</sub> , mg/l	77		MCRT, days	<b>18.0</b>
TSS, mg/l	<b>69</b>	<b>10.0</b>	Wastewater Temperature, °C	20
TSS, lbs/day	472	68.6	<b>Aerobic Digester</b>	
Ammonia-N, mg/l	<b>9.1</b>	<b>1.0</b>	Volume, % of Aeration Tank	42.0
Ammonia-N, lbs/day	62.4	6.9	Maximum MLSS, mg/l	15,000
TN, mg/l (assumes rDON < 1.0 mg/l)		<b>5.0</b>	Maximum MLSS, %	1.50%
TN, lbs/day		34.3	Digester Temperature, °C	20
Phosphorus-P, mg/l	<b>7.0</b>	<b>N/A</b>	<b>Sludge Holding Tank</b>	
Phosphorus-P, lbs/day	48.0	N/A	Volume, % of Aeration Tank	0.0
Net Alkalinity Loss, mg/l as CaCO <sub>3</sub>		<b>(55)</b>	Maximum MLSS, mg/l	25,000
			Maximum MLSS, %	2.50%

**PROJECTED OPERATING CONDITIONS - AERATION BASIN**

Mixed Liquor Suspended Solids, mg/l	<b>2,724</b>
Excess MLSS due to Phos-P Uptake/Removal, mg/l	0
Mixed Liquor Volatile Suspended Solids, %	69%
F/M Ratio, lbs BOD <sub>5</sub> /lb MLVSS	0.11
F/M Ratio, lbs BOD <sub>5</sub> /lb MLSS	0.08
Organic Loading, lbs BOD <sub>5</sub> /1000 cf of tank/day	13.0
Oxygen Requirements (Carbonaceous), mg/l/hr	8.44
Oxygen Requirements (Nitrogenous), mg/l/hr	6.18
Solids Production, lbs/day	261
WAS - Solids Wasted per Day, lbs/day	242
WAS - Solids Wasted per Day, gal/day @ 0.27%	10,667

**PROJECTED OPERATING CONDITIONS - AEROBIC DIGESTER**

Volatile Solids Reduction in Digester, %	31%
Solids Wasted from Digester, lbs/day	191
Mass Solids Yield in Process & Digester per Mass Influent BOD <sub>5</sub> , %	72%
Volume Wasted from Digester, gallons/day	1,525
Digester Sludge Age, days	<b>57</b>
Air Required for Stabilization, scfm	65
Air Required for Mixing @ 30 cfm/1000 cf	348

**Aero-Mod, Inc.**  
**AERATION DESIGN CALCULATIONS**

**Project:** Lone Tree, IA  
**Engineer:** Veenstra & Kimm, Inc.  
**Diffuser Type Used:** Tubular EPDM Fine Bubble

**Date:** 5-Aug-16  
**Units:** English

	<u>Design</u>	<u>Peak</u>		<u>Design</u>	<u>Peak</u>
Q, MGD	0.822	N/A	TKN <sub>0</sub> , mg/l	11.4	N/A
BOD <sub>0</sub> , mg/l	53	N/A	TKN <sub>assimilation</sub> , mg/l	2.3	N/A
BOD <sub>rem</sub> , mg/l	53	N/A	TKN <sub>rem</sub> , mg/l	11.4	N/A
BOD <sub>rem</sub> , lb/day	360	N/A	TKN <sub>rem</sub> , lb/day	78.0	N/A
O <sub>2</sub> Requirement, lb O <sub>2</sub> /lb BOD <sub>rem</sub>	1.800		O <sub>2</sub> Requirement, lb O <sub>2</sub> /lb TKN <sub>rem</sub>	4.60	

**AERATION REQUIREMENTS - FIRST STAGE**

	<u>Design</u>	<u>Peak</u>
Removal in First Stage	65%	65%
BOD <sub>oxy</sub> - Oxygen Required for BOD [Q * BOD <sub>rem</sub> * 8.34 * O <sub>2</sub> Req. / 24], lbs O <sub>2</sub> /hr	17.6	N/A
TKN <sub>oxy</sub> - Oxygen Required for TKN [Q * TKN <sub>rem</sub> * 8.34 * O <sub>2</sub> Req. / 24], lbs O <sub>2</sub> /hr	9.7	N/A
<b>Actual Oxygenation Rate (AOR), lbs O<sub>2</sub>/hr</b>	<b>27.3</b>	<b>N/A</b>
<b>Standard Oxygenation Rate (SOR), lbs O<sub>2</sub>/hr</b>	<b>69.9</b>	<b>N/A</b>
SOR = [(AOR * C <sub>s,20</sub> ) / (α * θ <sup>(T-20)</sup> * (Tau * Ω * β * C <sub>s,20</sub> - C <sub>L</sub> ) * F)]		

Where:	Parameter	Value	Parameter	Value
C <sub>s,T,H</sub>	Actual Value of D.O. Saturation, mg/l	9.08	C <sub>L</sub>	Residual D.O. Conc., mg/l
C <sub>s,20</sub>	Steady State Value of D.O. Saturation, mg/l	9.08	T	Temperature of Water, °C
Tau	Oxygen Saturation Value (C <sub>s,T,H</sub> /C <sub>s,20</sub> )	1.000	F	Diffuser Fouling Factor
α	Alpha - Oxygen Transfer Correction Factor for Waste	0.65	θ	Theta - Oxygen Transfer Coeff
β	Beta - Salinity-Surface Tension Correction Factor	0.95		Site Elevation, FASL
P <sub>H</sub>	Atmospheric Pressure at Site Elevation, psi	14.34	Ω	Omega (P <sub>H</sub> /P <sub>s</sub> )
				0.975

**Air Requirement = [SOR / (Oxygen Density \* TE% \* Diffuser Depth) / 60], scfm**      **256**      **N/A**

Where:	Parameter	Value	Parameter	Value
Oxygen Density, lbs O <sub>2</sub> /cf	0.0175	Diffuser Depth Below Water Surface, ft	13.0	
Transfer Efficiency per Foot of Submergence, %	2.00%			

**Denitrification Credit = [Air Rqmt \* (TKN<sub>oxy</sub> / AOR) \* 50% \* ((TKN<sub>0</sub> - TN<sub>e</sub>) / TKN<sub>0</sub>)], scfm**      **0**      **N/A**

Where:	Parameter	Value
TN <sub>e</sub>	TKN <sub>0</sub> / 2 (assumed when D.O. control is not used)	

**Total Aeration Required in Aeration Basin, scfm**      **256**      **N/A**

**Air Correction**

**icfm = scfm / [((T<sub>std</sub> + 460) / (T<sub>air</sub> + 460)) \* ((P<sub>H</sub> - (RH% \* SVP<sub>Tair</sub>)) / (14.7 - (RH%<sub>std</sub> \* SVP<sub>std</sub>))) \* ((P<sub>A</sub> / P<sub>H</sub>))]**

Where:	Parameter	Value	Parameter	Value
T <sub>std</sub> , °F	68	T <sub>air</sub>	Maximum Air Temperature, °F	
RH% <sub>std</sub>	36%	RH%	Maximum Relative Humidity, %	
SVP <sub>std</sub> , psi	0.34	SVP <sub>Tair</sub>	Saturated Vapor Pressure of Air @ T <sub>air</sub> , psi	
		P <sub>A</sub>	Actual Atmospheric Pressure after Blower Inlet, psi	
			14.14	

Minimum Air Required for Mixing in First Stage Aeration Basin, cfm	139	Side Roll
Minimum Air Required for Mixing in Second & Third Stage Aeration Basin, cfm	178	Side Roll
Minimum Air Required for Operating Full Plant, cfm (mixing requirement for 24 hrs)	552	

	<u>Design</u>	<u>Peak</u>	<u>Design</u>	<u>Peak</u>
Aeration Pressure, in. H <sub>2</sub> O	192	192		
psi, std (does not include blower inlet/outlet)	6.9	6.9		
	scfm	scfm	icfm	icfm
Aeration Basin - Fine Bubble	256	0	302	0
Aeration Basin - Coarse Bubble	230	0	271	0
Aerobic Digester Tank (sequenced aeration)	174	0	174	0
Selector Tank	14	0	14	0
Post Aeration Tank	11	0	13	0
Clarifier RAS Airlift Pumps & Skimmers	105	0	105	0
Total Air Required	790		880	
Total Air Available			1,054	

**POWER REQUIREMENTS**

	Unit	Power	Power
Operating Power for Aeration Basin, HP	Blower	24.1	
Operating Power for Digester, HP	Blower	7.3	
Operating Power for Selector Tank, HP	Blower	0.6	
Operating Power for Post Aeration Tank, HP	Blower	0.6	
Operating Power for Clarifier, HP	Blower	4.4	
Operating Power for Pneumatic System, HP	Air Compr.	0.5	
<b>Operating Power Required at Full Loading, HP</b>		<b>37.5</b>	
<b>Minimum Power Required to Operate Full Plant, HP</b>		<b>25.5</b>	

# Aero-Mod, Inc.

## AERATION DESIGN CALCULATIONS

**Project:** Lone Tree, IA  
**Engineer:** Veenstra & Kimm, Inc.  
**Diffuser Type Used:** Stainless Steel Coarse Bubble

**Date:** 5-Aug-16  
**Units:** English

### AERATION REQUIREMENTS - SECOND & THIRD STAGE

	Design	Peak
Removal in Second Stage	35%	35%
Oxygen Required for BOD [ $Q * BOD_{rem} * 8.34 * O_2 \text{ Req.} / 24$ ], lbs O <sub>2</sub> /hr	9.5	N/A
Oxygen Required for TKN [ $Q * TKN_{rem} * 8.34 * O_2 \text{ Req.} / 24$ ], lbs O <sub>2</sub> /hr	5.2	N/A
<b>Actual Oxygenation Rate (AOR), lbs O<sub>2</sub>/hr</b>	<b>14.7</b>	<b>N/A</b>
<b>Standard Oxygenation Rate (SOR), lbs O<sub>2</sub>/hr</b>	<b>27.7</b>	<b>N/A</b>

$$SOR = [(AOR * C_{s,20}) / (\alpha * \theta^{(T-20)} * (Tau * \Omega * \beta * C_{s,20} - C_L) * F)]$$

Where:	C <sub>s,T,H</sub> Actual Value of D.O. Saturation, mg/l	9.08	C <sub>L</sub> Residual D.O. Conc, mg/l	2.0
	C <sub>s,20</sub> Steady State Value of D.O. Saturation, mg/l	9.08	T Temperature of Water, °C	20
	Tau Oxygen Saturation Value (C <sub>s,T,H</sub> /C <sub>s,20</sub> )	1.000	F Diffuser Fouling Factor	1.00
	α Alpha - Oxygen Transfer Correction Factor for Waste	0.75	θ Theta - Oxygen Transfer Coeffi	1.024
	β Beta - Salinity-Surface Tension Correction Factor	0.95	Site Elevation, FASL	680
	P <sub>H</sub> Atmospheric Pressure at Site Elevation, psi/FASL	14.34	Ω Omega (P <sub>H</sub> /P <sub>s</sub> )	0.975

**Air Requirement = [SOR / (Oxygen Density \* TE% \* Diffuser Depth) / 60], scfm** **230**      **N/A**

Where:	Oxygen Density, lbs O <sub>2</sub> /cf	0.0175	Diffuser Depth Below Water Surface, ft	13.5
	Transfer Efficiency per Foot of Submergence, %	0.85%		

**Denitrification Credit = [Air Rqmt \* (TKN<sub>oxy</sub> / AOR) \* 50% \* ((TKN<sub>o</sub> - TN<sub>e</sub>) / TKN<sub>o</sub>)], scfm** **0**      **N/A**

Where: TN<sub>e</sub> = TKN<sub>o</sub> / 2 (assumed when D.O. control is not used)

**Total Aeration Required in Aeration Basin, scfm** **230**      **N/A**

### Air Correction

$$icfm = scfm / [((T_{std} + 460) / (T_{air} + 460)) * ((P_H - (RH\% * SVP_{Tair})) / (14.7 - (RH\%_{std} * SVP_{std}))) * ((P_A / P_H))]$$

Where:	T <sub>std</sub> , °F	68	T <sub>air</sub> Maximum Air Temperature, °F	104
	RH% <sub>std</sub>	36%	RH% Maximum Relative Humidity, %	90%
	SVP <sub>std</sub> , psi	0.34	SVP <sub>Tair</sub> Saturated Vapor Pressure of Air @ T <sub>air</sub> , psi	1.058
			P <sub>A</sub> Actual Atmospheric Pressure after Blower Inlet, psi	14.14

Minimum Air Required for Mixing in Second & Third Stage Aeration Basin, cfm 178      Side Roll

Aeration Pressure, in. H<sub>2</sub>O 186      186  
 psi, std (does not include blower inlet/outlet) **6.7**      **6.7**

	<u>Design</u>	<u>Peak</u>	<u>Design</u>	<u>Peak</u>
	scfm	scfm	icfm	icfm
Aeration Basin - Coarse Bubble	230	0	271	0

# Aero-Mod, Inc.

## CLARIFIER DESIGN CALCULATIONS

**Project:** Lone Tree, IA  
**Engineer:** Veenstra & Kimm, Inc.  
**Clarifier Type Used:** Split-ClarAstor

**Date:** 5-Aug-16  
**Units:** English

### FLOW CONDITIONS

Design Flow, MGD	0.822	
Peaking Factor, hourly	1.00	0.822 MGD
Duration, min	60	
Peaking Factor, sustained	1.00	0.822 MGD
Aeration Tank Volume, Mgal	0.207	
MLSS, mg/l	3,000	
Avg. RAS Recycle Rate, %	150%	

### EQUIPMENT SIZING & SELECTION

Number of Clarifiers	<b>4</b>	Surface Area per Clarifier, sf	432
Clarifier Unit Model	<b>24432</b>	Total Surface Area, sf	<b>1,728</b>
Bridge Length, ft	24	Total Weir Length, ft	180
Clarifier Unit Width, ft	18	Tank Wall Depth, ft	16.0
Number of Units per Clarifier	1	Tank Water Depth, ft	14.0

### SURFACE OVERFLOW RATE

	<u>Design</u>
Design Flow, gpd/sf	<b>476</b>
Peak Day Flow, gpd/sf	476
Peak Hour Flow, gpd/sf	476
Max. Flow Allowed Through Clarifier Orifice, gpd/sf	1,000 * Max allowed to leave clarifier

### WEIR OVERFLOW RATE

Design Flow, gpd/lin. ft	<b>4,567</b>
Peak Flow, gpd/lin. ft	4,567

### SOLIDS LOADING RATE

Design Flow, lbs/day/sf	<b>29.8</b>
Peak Flow, lbs/day/sf	29.8

### RETENTION TIME - including RAS

Design Flow, hr	<b>2.1</b>
Peak Flow, hr	2.1

# Aero-Mod, Inc.

## CLARIFIER DESIGN CALCULATIONS

**Project:** Lone Tree, IA  
**Engineer:** Veenstra & Kimm, Inc.  
**Clarifier Type Used:** Split-ClarAstor

**Date:** 5-Aug-16  
**Units:** English

### FLOW CONDITIONS

#### Largest Clarifier out of Service

Design Flow, MGD	0.617	75% of Flow
Peaking Factor, hourly	1.00	0.617 MGD
Duration, min	60	
Peaking Factor, sustained	1.00	0.617 MGD
Aeration Tank Volume, Mgal	0.207	
MLSS, mg/l	3,000	
Avg. RAS Recycle Rate, %	150%	

### EQUIPMENT SIZING & SELECTION

Number of Clarifiers	<b>3</b>	Surface Area per Clarifier, sf	432
Clarifier Unit Model	<b>24432</b>	Total Surface Area, sf	<b>1,296</b>
Bridge Length, ft	24	Total Weir Length, ft	135
Clarifier Unit Width, ft	18	Tank Wall Depth, ft	16.0
Number of Units per Clarifier	1	Tank Water Depth, ft	14.0

### SURFACE OVERFLOW RATE

	Design
Design Flow, gpd/sf	<b>476</b>
Peak Day Flow, gpd/sf	476
Peak Hour Flow, gpd/sf	476
Max. Flow Allowed Through Clarifier Orifice, gpd/sf	1,000 * Max allowed to leave clarifier

### WEIR OVERFLOW RATE

Design Flow, gpd/lin. ft	<b>4,567</b>
Peak Flow, gpd/lin. ft	4,567

### SOLIDS LOADING RATE

Design Flow, lbs/day/sf	<b>29.8</b>
Peak Flow, lbs/day/sf	29.8

### RETENTION TIME - including RAS

Design Flow, hr	<b>2.1</b>
Peak Flow, hr	2.1



# Aero-Mod, Inc.

## TANKAGE DESIGN CALCULATIONS

**Project:** Lone Tree, IA  
**Engineer:** Veenstra & Kimm, Inc.  
**Tank Construction:** Cast-in-Place Concrete

**Date:** 5-Aug-16  
**Units:** English

### SELECTOR TANK

<b>Anoxic Selector</b>	Volume Required, gal	<b>9,792</b>	
Number of Tanks	1	Tank Width, ft	9.0
Tank Wall Height, ft	16.0	Tank Length, ft	11.0
Tank Water Depth, ft	14.0	Total Volume, gallons	<b>10,367</b>
Freeboard, ft	2.0	Retention Time (Design + RAS), min.	7

### AERATION TANK

	Volume Selected, gal	<b>206,717</b>	
Tank Wall Height, ft	16.0	Number of Trains	2
Tank Water Depth, ft	14.0	Number of Stages	2

<u>Stage 1</u>		<u>Stage 2</u>	
Number of Tanks	2	Number of Tanks	2
Tank Length, ft	45.0	Tank Length, ft	29.0
Tank Width, ft	11.0	Tank Width, ft	12.0
Area of Each Tank, sf	495	Area of Each Tank, sf	348
Total Volume, gallons	<b>103,673</b>	Total Volume, gallons	<b>72,885</b>
<u>Stage</u>		<u>Stage 3</u>	
Number of Tanks	0	Number of Tanks	4
Tank Length, ft	0.0	Tank Length, ft	18.0
Tank Width, ft	0.0	Tank Width, ft	4.0
Area of Each Tank, sf	0	Area of Each Tank, sf	72
Total Volume, gallons	<b>0</b>	Total Volume, gallons	<b>30,159</b>

Total volume provided, gal **206,717**

### CLARIFIER TANK

Number of Tanks	4	Tank Width, ft	18.0
Tank Wall Height, ft	16.0	Tank Length, ft	24.0
Tank Water Depth, ft	14.0	Total Volume, gallons	<b>180,956</b>

### POST AERATION TANK - At Peak Flow (assumed dimensions to calculate air required)

Number of Tanks	1	Tank Width, ft	8.0
Tank Wall Height, ft	12.0	Tank Length, ft	12.0
Tank Water Depth, ft	10.0	Total Volume, gallons	<b>7,181</b>
Oxygen Uptake Rate, mg/l/hr	14.3	Retention Time, min.	13

### AEROBIC DIGESTER TANK

	Volume Selected, gal	<b>86,768</b>	
Number of Tanks	2	Tank Width, ft	8.0
Tank Wall Height, ft	16.0	Tank Length, ft	50.0
Tank Water Depth, ft	14.5	Total Volume, gallons	<b>86,768</b>

### OVERALL TANKAGE DIMENSIONS

Total Length, ft	52.0	Wall Thickness, in	12.0
Total Width, ft	103.0	Floor Thickness, in	18.0
Total Area, sf	5,356	Total Concrete for Walls, cy	<b>450</b>
Total Wall Length, LF	759	Total Concrete for Slab, cy	<b>315</b>
		Total Grout for Clarifier, cy	<b>116</b>

**Aero-Mod, Inc.**  
**EQUIPMENT AND SERVICES COST ESTIMATE**

**Project:** Lone Tree, IA  
**Engineer:** Veenstra & Kimm, Inc.

**Date:** 5-Aug-16  
**Units:** English

**EQUIPMENT SUPPLIED**

**AERATION EQUIPMENT**

- 2 Aeration pd blower/sound enclosure package, 50 HP - 460 V, 3 ph
- 4 SEQUOX aeration control butterfly valve, pneumatically-actuated
- 4 SEQUOX aeration throttling butterfly valve, gear-operated
- 2 Aeration throttling butterfly valve, gear-operated
- 14 Wall mounted aeration assembly, Model WA-PF6 - First Stage Aeration Basins
- 8 Wall mounted aeration assembly, Model WA-PS4-2 - Second Stage Aeration Basins
- 8 Wall mounted aeration assembly, Model WA-HSS2 - Third Stage Aeration Basins

**SELECTOR TANK EQUIPMENT**

- 1 Wall mounted aeration assembly, Model WAD-HSS2

**CLARIFIER & RAS EQUIPMENT**

- 4 Aero-Mod Split-ClarAto Clarifier System - 432 sf/each
- 4 Algae Control Transducer - 115V

**DIGESTION, SLUDGE HOLDING & WAS EQUIPMENT**

- 2 WAS airlift pump, Model AL-400
- 2 Aeration control butterfly valve, pneumatically-actuated
- 2 Aeration control butterfly valve, gear-operated
- 10 Wall mounted aeration assembly, Model WAD-HS2

**ELECTRICAL & CONTROLS EQUIPMENT**

- 1 SEQUOX Process Control Panel w/ Allen Bradley PLC, Model SQC-200-PLC - 115 V
- 2 Blower control panel w/ Allen Bradley VFD - 460 V, 3 ph
- 2 Saylor-Beall air compressor, 3 HP with 60 gallon tank - 460 V, 3 ph
- 1 Compressed air alternation panel - 115 V
- 2 Air compressor auto-drain - 115 V wall outlet
- 1 PureGas regenerative desiccant dryer mounted on dry storage tank - 115 V wall outlet
- 1 D.O. Control System - probe analyzer w/ 2 rail-mounted DO probes

**ANCILLARY EQUIPMENT**

- 306 Wall mounted walkway & handrail, LF
- 7 Wall mounted stop plates & frames
  - 7 SS wall-mounted frames
  - 3 Aluminum stop plates
  - 2 Aluminum weir plates
- LS Spare Parts
- LS Interior tank installation materials - SS brackets, SS bolts, PVC wall inserts, pneumatic tubing, misc.

**SERVICES**

- LS Freight to jobsite
- LS Aero-Mod equipment dry inspection/equipment start-up & training, two (2) days
- LS Aero-Mod biological training, two (2) days
- LS Operator training school - 2 days at Aero-Mod facilities in Manhattan, KS

**TOTAL EQUIPMENT COST** **\$753,900**

**EST'D INSTALLATION of Aero-Mod EQUIPMENT by Contractor** **\$140,000**  
*(Includes Interior Tank PVC Piping)*

**ESTIMATED CONCRETE TANK COST by Contractor** **\$600,000**

Concrete for Tank Walls, cy	450
Installed Concrete Cost, \$/cy	\$750
Concrete for Tank Slab, cy	315
Installed Concrete Cost, \$/cy	\$650
Grout for Clarifier Bottom, cy	116
Installed Concrete Cost, \$/cy	\$550

**ESTIMATED COST** **\$1,493,900**

**PLEASE NOTE THE FOLLOWING**

1. Buildings, site work, and auxiliary equipment are not included within this estimate.
2. No RAS pump station and associated electrical requirements are required.
3. Yard piping is not required between each Aero-Mod tank.
4. All associated walkways & handrail for the clarifier and tankage are included in the above estimate.
5. This estimate is valid for 90 days from the above date.

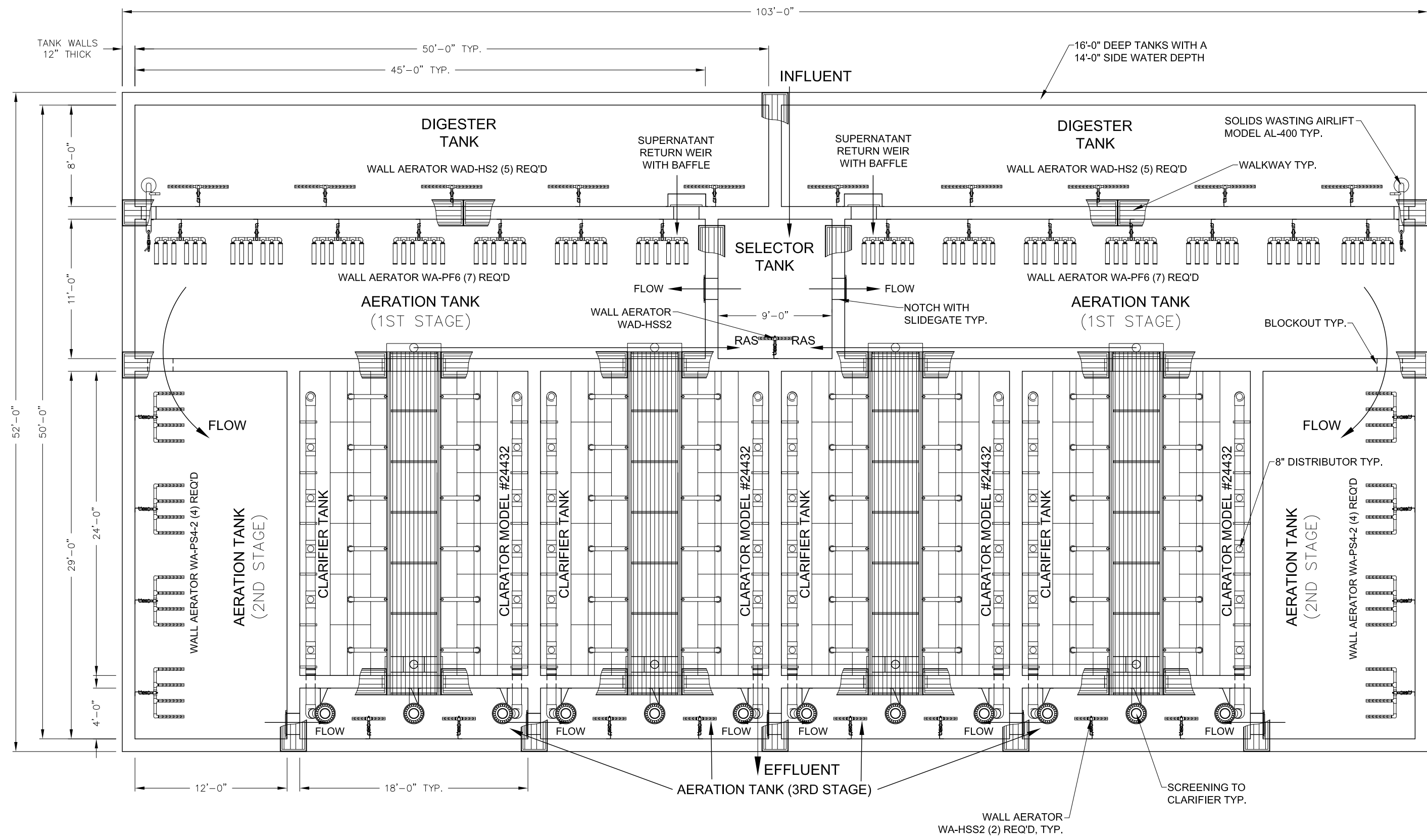

TANK WALLS  
12" THICK

103'-0"

16'-0" DEEP TANKS WITH A  
14'-0" SIDE WATER DEPTH

DIGESTER  
TANK

WALL AERATOR WAD-HS2 (5) REQ'D

SUPERNATANT  
RETURN WEIR  
WITH BAFFLE

SUPERNATANT  
RETURN WEIR  
WITH BAFFLE

DIGESTER  
TANK

WALL AERATOR WAD-HS2 (5) REQ'D

SOLIDS WASTING AIRLIFT  
MODEL AL-400 TYP.

WALKWAY TYP.

SELECTOR  
TANK

WALL AERATOR WA-PF6 (7) REQ'D

WALL AERATOR WA-PF6 (7) REQ'D

AERATION TANK  
(1ST STAGE)

WALL AERATOR  
WAD-HSS2

NOTCH WITH  
SLIDE GATE TYP.

AERATION TANK  
(1ST STAGE)

BLOCKOUT TYP.

FLOW

AERATION TANK  
(2ND STAGE)

WALL AERATOR WA-PS4-2 (4) REQ'D

CLARIFIER TANK

CLARATOR MODEL #24432

CLARIFIER TANK

CLARATOR MODEL #24432

CLARIFIER TANK

CLARATOR MODEL #24432

CLARIFIER TANK

CLARATOR MODEL #24432

AERATION TANK  
(2ND STAGE)

8" DISTRIBUTOR TYP.

WALL AERATOR WA-PS4-2 (4) REQ'D

FLOW

EFFLUENT

AERATION TANK (3RD STAGE)

WALL AERATOR  
WA-HSS2 (2) REQ'D, TYP.

SCREENING TO  
CLARIFIER TYP.

52'-0"

50'-0"

29'-0"

24'-0"

11'-0"

8'-0"

12'-0"

18'-0" TYP.

50'-0" TYP.

45'-0" TYP.

Date: 8/4/15  
Scale: NTS  
Drawn by: CKC  
Title:

**Aero - Mod, Inc.**

W.W.T.P. PLANVIEW  
LONE TREE, IOWA

Property of Aero-Mod Inc., all rights reserved. No part of this drawing may be reproduced in any form without permission in writing from Aero-Mod Inc. Aero-Mod Inc. reserves the right to alter this data or the design of its equipment at any time, without prior notice and without incurring any obligation whatsoever.

7927 U.S. Highway 24  
Manhattan, Kansas 66502  
PHONE: (785) 537-4995  
FAX: (785) 537-0813

APPENDIX E - ENHANCED AERATED LAGOON PROPOSALS

OPTAER/SAGR (NEXOM, INC.)  
LEMTEC (LEMNA TECHNOLOGIES, INC.)  
IDEAL (EDI, INC.)



**OPTAER™**  
WASTEWATER TREATMENT SYSTEM



**Proposal for:**

**Design, Supply, and Installation Inspection of**

**OPTAER Lagoon and SAGR Wastewater Treatment System Option 2  
Lone Tree, IA**

**Design Option 2 – Proposed Modifications to Assessment No. 11-1**

**August 4, 2016**

*NE reference: cd2872.01 Opt 2 Mods 3 Proposal*

## 1.0 Project Overview

---

An OPTAER Wastewater Treatment system is proposed for the Community of Lone Tree, IA. The proposed system would upgrade the existing lagoon infrastructure. The process would consist of the following processes and technologies

- Retain the existing lagoon infrastructure for primary and secondary treatment (condition and suitability to be confirmed by others).
- Divide existing Cell 1 into two zones using a floating geomembrane baffle curtain
- Divide existing Cell 2 into two zones, 1 partial mix and 1 settling using a floating geomembrane baffle curtain
- Implement OPTAER fine bubble partial mix aeration in newly divided cells 1a, 1b and 2a.
- Construct a four (4)-cell aerated Horizontal Flow SAGR<sup>®</sup> (Submerged Attached Growth Reactor) for nitrification (ammonia removal) following Cell 2b.
- UV Disinfection system after the SAGR process if required (by others).

The OPTAER system utilizes a SAGR, designed according to revision “Mods 3” proposed to the Iowa DNR New Wastewater Technology Assessment No. 11-1.

## 2.0 System Design Parameters

---

Preliminary design loads, flows, and effluent objectives are summarized in the following tables:

		Lagoon Influent	SAGR Influent	SAGR Effluent
<b>Design Flow AWW</b>	mgd	0.822	0.822	
<b>Design Flow ADW</b>	mgd	0.176		
<b>Iowa Standard Design Flow**</b>	mgd	0.370		
<b>cBOD<sub>5</sub></b>	lbs/day	360		
<b>cBOD<sub>5</sub></b>	mg/L		25	<20
<b>TSS</b>	lbs/day	472		
<b>TSS</b>	mg/l		25	<20
<b>TKN</b>	lbs/day	78	78	
<b>TAN</b>	mg/L			*varies

\*ammonia limits vary seasonally

Section VI: Water Quality -Based Permit Limits (see table below):

\*\*ADW plus 30% of (AWW minus ADW)

Anticipated seasonal ammonia limits are shown in the following table:

Ammonia - N New Limits			
Month	Average (mg/l)	Month	Average (mg/l)
January	5.2	July	1.1
February	5.8	August	1.0
March	3.9	September	1.5
April	2.1	October	2.7
May	1.8	November	2.7
June	1.3	December	3.9

Approximate basin sizes are shown in the following tables:

Cell	Basin Type	Water Depth (ft)	Water Volume(gallons)
1a	Aerated Partial Mix	6	5,061,469
1b	Aerated Partial Mix	6	4,825,429
2a	Aerated Partial Mix	8	3,194,900
2b	Settling	8	429,681
	SAGR	7	
	<b>Totals</b>		<b>13,511,480</b>

Lagoon aeration design parameters are summarized in the following tables:

Aeration Design Parameters - OPTAER Fine Bubble System					
	Cell 1a (PM)	Cell 1b (PM)	Cell 2a (PM)	Cell 2b (Settling)	Total
Alpha	0.60	0.60	0.60	0.60	
Beta	0.95	0.95	0.95	0.95	
Theta	1.024	1.024	1.024	1.024	
Site elevation (ft)	676	676	676	676	
Min. Dissolved Oxygen (mg/l)	2.0	2.0	2.0	2.0	
# HT25 diffusers (design)	32	12	4	-	<b>48</b>
SCFM per diffuser	12	12	12	-	
<b>Total SCFM (design)</b>	<b>384</b>	<b>144</b>	<b>48</b>	<b>-</b>	<b>576</b>

SAGR design parameters are summarized in the following table:

<b>SAGR Design Parameters</b>			
	<b>Iowa DNR Requirement</b>	<b>Design</b>	<b>One cell out of service (75%)**</b>
Alpha	-	0.70	0.70
Beta	-	0.95	0.95
Theta	-	1.024	1.024
Site elevation (ft)	-	676	676
SAGR Loading Rate (lbs BOD/100ft <sup>2</sup> /day)	≤ 2.5/3.75	2.4	3.67
SAGR Loading Rate (lbs NH <sub>3</sub> /1000 ft <sup>3</sup> )	≤ 0.40	0.398	0.398
Actual AWW HRT (hours) (porosity of 0.4)	≥ 9	17	17
Actual 18C HRT (hours) (porosity of 0.4)	≥ 24	38	38
Min. Dissolved Oxygen (mg/l)	≥ 3.0	3.0	3.0
Total SCFM	-	648	648

\*\*System has 75% design load and flow capacity with one cell out of service

### **3.0 OPTAER Treatment Process**

#### **i. Partial Mix (PM) Cell**

The primary purpose of the aerated ponds is to provide oxygen, residence and contact time to natural bacteria which ultimately convert the wastewater contaminants (BOD<sub>5</sub>, ammonia (in warm temperatures), and TSS) to carbon dioxide, water, inert ash and nitrates. Aerated ponds effectively control odours and provide internal sludge digestion.

With aerated partial mix cells, the diffuser density is based upon oxygen demand. The OPTAER system does not rely on algae or natural surface aeration for providing oxygen to the wastewater.

The diffusers are suspended near the bottom of the cells. Through the rise of the bubbles and subsequent mixing, convection cells are created between the diffusers. Not only does the water rise with the bubbles, the solids settle out through the downward motion of the water between the diffusers where the circulation loop is completed. This combined with the slow rate of bubble rise contributes to the overall efficiency of the system. Because of low sludge production in the system, retention time is retained for long term BOD<sub>5</sub> removal.

When the solids reach the bottom of the lagoon, additional oxygen for biodegradation is provided through the diffusers near the cell bottom. This process results in minimal organic bottom sludge accumulation. Aerobic digestion takes place within the aerated cells at the sludge water interface.



## ii. Impermeable Floating Baffles

Impermeable flow diversion baffles are used to create multiple treatment cells in new or existing lagoons. Existing lagoons 1 and 2 will each be divided into two (2) treatment cells (1a / 1b, 2a / 2b) to improve treatment and settling as well as minimize the potential for short circuiting.

## iii. HT-25 Fine Bubble Membrane Diffusers (Aerated Partial Mix)

HT-25 fine bubble diffusers are used to provide oxygen to the wastewater. The diffusers consist of an HDPE air distribution body with individual tubular EPDM membranes extending outwards in a horizontal plane. This design prevents bubbles from coalescing, and results in an excellent oxygen transfer rate with minimal head loss.

The diffusers are suspended with a marine grade rope directly under the lateral, at a uniform depth. The rope is attached to the floating header for ease of diffuser retrieval. Each diffuser is attached to a small concrete weight, encased in HDPE pipe. Diffuser assemblies can be retrieved from a boat with no special equipment.



## iv. OPTAER Header System (Aerated Cell) to be supplied by others

A metal manifold and discharge piping are used to dissipate the heat produced by the blowers. Shallow buried HDPE header piping connects to the galvanized steel manifold, and supplies air to the floating laterals. The header has flanged connections for each lateral as shown on the drawings. Each lateral is individually valved for ease of maintenance.

Laterals connect to the shallow buried header, and float on the water surface. With floating laterals, there are no concrete weights required to be in contact with the bottom of the basin. Laterals are secured against wind action with a stainless steel cable system. The cables are fastened to anchors in the berm using a self-adjusting lateral tensioning assembly. All header and lateral piping, joints, and fittings are thermally fused HDPE.



With floating laterals, the cells do not have to be dewatered or taken out of service for system installation or maintenance. All maintenance can be performed from a boat with a 2-person crew.

All header, lateral, and feeder piping is designed to accommodate increased airflow for high pressure and volume cleaning without increasing header friction losses by more than 1 psi. This allows for management of additional organic load, improved diffuser maintenance and additional odor control.

## v. Submerged Attached Growth Reactor (SAGR)

The Submerged Attached Growth Reactor (SAGR) is a patented process designed to provide nitrification (ammonia removal) in cold to moderate climates. The SAGR is a clean gravel bed with evenly distributed wastewater flow across the width of the cell, and a horizontal collection chamber at the end of the treatment zone. LINEAR aeration throughout the floor of the SAGR provides aerobic conditions that are required for nitrification. The gravel bed is covered with a layer of peat or wood chips for insulation.

The following variables need to be considered during nitrification design:

- *Dissolved Oxygen Levels* - Nitrifying bacteria require aerobic conditions. A minimum dissolved oxygen concentration of 3 mg/L must be present for the process to occur.
- *BOD concentration* – Nitrifying bacteria require low BOD concentrations to be effective. Primary BOD removal occurs in the upstream treatment system. The SAGR provides additional BOD polishing if necessary to reduce BOD concentrations below 25 mg/l.
- *Surface area* - Bacteria require a medium of some form to grow on. High surface area medium allows for higher-density nitrifying bacteria population.
- *Bacteria* - In order to convert ammonia ( $\text{NH}_3$ ) to nitrite ( $\text{NO}_2^-$ ) and ultimately nitrate ( $\text{NO}_3^-$ ) (nitrification) sufficient quantities of two bacteria are required, *Nitrosomonas* and *Nitrobacter*.
- *Alkalinity* - The nitrification process reduces pH levels and consumes alkalinity. In order for nitrification to occur, 7.1 mg of alkalinity must be available for each mg of ammonia removed.
- *Temperature* - Nitrification in a Submerged Attached Growth Reactor occurs at water temperatures as low as 0.5°C. The long sludge age inherent in an attached growth system allows for full nitrification at temperatures where bacterial reproduction is greatly inhibited.
- *pH* - Nitrification is enhanced at higher pH level. pH levels of 7.5 to 8.5 are ideal, although nitrifying bacteria can adapt outside of this range.
- *Aggregate Media* – Locally available aggregate may be used, provided it conforms to the aggregate media requirements specified in the Iowa DNR New Wastewater Technology Assessment No. 11-1.
- *Insulating material* – Peat Mulch, Compost, or woodchips may be used. Insulating material should be a minimum of 8 inches thick and conform to the conditions provided in the Iowa DNR New Wastewater Technology Assessment No. 11-1.

Four (4) SAGR cells are operated in two (2) parallel trains. Piping allows any cell to be isolated and bypassed. The SAGR has the capacity to treat 75% of the influent flow with any one cell out of service.

#### **vi. Submerged Attached Growth Reactor (SAGR) LINEAR Aeration System**

LINEAR coarse bubble diffusers are used to provide oxygen to the wastewater. Diffuser lines are manufactured from LDPE (Low Density Polyethylene) with reinforced air releases along the tubing. The diffuser tubing is designed for direct burial in the SAGR bed. The diffuser locations have been spaced according to the projected oxygen demand in the SAGR. The design diffuser distribution is critical to ensure that nitrification occurs.

In addition to providing oxygen for nitrification, the proposed aeration system brings numerous other long-term performance benefits to this sub-surface flow system:

- Full aeration grid ensures that wastewater channeling cannot occur in the gravel layer (maximize retention time and media contact).
- Sludge digestion in gravel layer is enhanced due to aerobic conditions.
- Year-around odor-free operation.

#### **vii. SAGR HDPE Header & Feeder System to be supplied by others**

High Density Polyethylene (HDPE) laterals run along the top on each side of the SAGR. The laterals are located in the top layer of insulating mulch. All HDPE piping connections and fittings are thermally fused to ensure maximum strength and durability. A shallow buried air supply header (by others) connects blowers to the SAGR laterals.

HDPE service saddles are thermally fused to the lateral piping for each diffuser line. HDPE drop legs provide air to the individual diffuser lines.

All header and feeder piping is designed to accommodate increased airflow for high pressure and volume cleaning without increasing header friction losses by more than 1 psi. This allows for management of additional organic load, improved diffuser maintenance and additional odor control.

### viii. Positive Displacement Blowers

Positive displacement blowers are used for the air supply for the OPTAER treatment system. Blowers are designed to provide the required airflow at normal system operating pressure, and have the capability of operating at the maximum required pressure intermittently for diffuser purging. Blowers are compatible with variable frequency drives. The blowers are equipped with sound attenuating enclosures.

Blower requirements are summarized in the following table:

		<b>Lagoon Blowers</b>	<b>SAGR Blowers</b>
Number of blowers total		1	2
Number of blowers on duty		1	1
Number of blowers on standby		0*	1
Motor nameplate horsepower	hp	30	40
Design airflow per blower	SCFM	576	648
Normal operating pressure	psi	4.4	5.2
Maximum Required Pressure	psi	6.8	8.2
Actual Power Consumption	bhp	19.9	25.5
Actual Sound level	dB(A)	70	71

\*Standby provided by SAGR blower

## 4.0 Operation and Maintenance

Anticipated system O&M requirements are summarized in the following table:

				*Electrical Rate:	0.08	\$/kW-h
	Motor Power		Monthly	Unit	Annual	
	Quantity	bhp	kW	cost	cost	Cost
Lagoon Blowers	1					
Normal Operating Conditions	1	19.9	14.8	\$867	-	\$10,404
Filters (6 months)	-	-	-	-	\$80	\$160
Oil (12 months)	-	-	-	-	\$70	\$70
Belts (24 months)	-	-	-	-	\$250	\$125
SAGR Blowers	2					
Normal Operating Conditions	1	25.5	19.0	\$1,111	-	\$13,331
Filters (6 months)	-	-	-	-	\$80	\$160
Oil (12 months)	-	-	-	-	\$70	\$70
Belts (24 months)	-	-	-	-	\$250	\$125
Diffuser Membrane Replacement	384	-	-	-	\$25	\$1,920
<b>Total Operation &amp; Materials</b>						<b>\$26,365</b>

\* Electrical rate estimated by Nelson Environmental Inc

The OPTAER system will require one operator for approximately 0.5 hour per day for routine inspection & maintenance.

## 5.0 Budgetary Capital Cost

---

Included in the budgetary capital cost for the OPTAER SAGR Wastewater Treatment System are the following:

### Lagoon Aeration System

- Process design support including
  - Process CAD drawings and specifications
- **Supply and installation inspection of:**
  - Aeration diffusers, feeder piping, HDPE lateral piping
  - Lateral support hardware and anchors, self-tensioning lateral anchor assemblies
  - One (1) 30 hp positive displacement blowers each with sound attenuating enclosures
  - Two (2) floating flow diversion baffles
- **OPTAER installation inspection/start-up/commissioning/training**
- Operation and maintenance manuals
- Project Record Drawings

### Submerged Attached Growth Reactor (SAGR)

- Process design including
  - Process CAD drawings and specifications
- **Supply and installation inspection of:**
  - SAGR Aeration feeder piping, diffusers, valves, and fittings as required
  - SAGR Influent flow distribution and effluent collection chambers
  - Two (2) 40 hp positive displacement blowers with sound attenuating enclosures
- **SAGR installation inspection /start-up /commissioning /training**
- Operation and maintenance manuals
- As-built Drawings

### Items Specifically Not Included:

- Material offloading and on-site storage
- Installation of NEI Supplied process equipment
- SAGR System Installation
- Civil works including Lagoon and SAGR basin design and construction, liner, transport piping, inter-cell piping, discharge piping, manholes, valves, access roads to site, site roads and landscaping, lagoon desludging etc. if required
- Influent splitter structures with flow control weirs or standpipes
- Blower manifold and discharge piping
- Blower control panel
- Standby generator if required
- Shallow buried air supply header piping
- Building to house blowers if required, including concrete, electrical, and HVAC and Power hookup

- Materials and construction required for the SAGR:
  - granular material
  - insulating wood chips or mulch
- Disinfection
- Restoration

**Budgetary Cost for the design, supply, and installation inspection of the SAGR system:**

**\$----- USD, plus taxes, FOB jobsite**

*All budgets are subject to final design review.  
All budgetary prices include shipping to jobsite but do not include taxes.  
Budget prices are valid for 90 days.*

## 6.0 Civil Works Required for SAGR Implementation (by others)

The intent of this proposal is not to provide details regarding civil works required but rather to provide a general overview as to the anticipated scope of work. The following quantities are not included in the Nelson Environmental scope of work, but are provided for cost estimation purposes only.

- Construct SAGR cells
- Construct inter-cell piping for lagoon/SAGR
- Construct discharge control structure after SAGR
- Materials and construction required specifically for the SAGR (estimated material quantities are shown in the following table):

<b>SUMMARY</b>				
Item Description	UOM	Quantity	Unit Price	Total Cost
Uniform Graded Clean Rock	cu.yd.	8,560	\$ 35.00	\$ 299,600.00
Insulating Wood Chips	cu.yd.	900	\$ 10.00	\$ 9,000.00
Non-Woven Geotextile (8oz)	sq.ft.	83,620	\$ 0.15	\$ 12,543.00
HDPE Liner (60mil)	sq.ft.	52,820	\$ 1.25	\$ 66,025.00
Wall Framing & Sheathing	lineal ft.	2,340	\$ 14.00	\$ 32,760.00
Influent Flow Splitter Structure	ea	2	\$ 7,500.00	\$ 15,000.00
Piping, fittings, valves from splitter to SAGR	LS	1	\$ 60,800.00	\$ 60,800.00
Effluent Level Control MH	ea	4	\$ 5,000.00	\$ 20,000.00
Install NEI supplied process equipment	LS	1	\$ 84,000.00	\$ 84,000.00
<i>Additional Civil Works (As Required)</i>				
Common Excavation - Backfill	cu.yd.	TBD	\$ -	\$ -
New Berm Construction	cu.yd.	TBD	\$ -	\$ -
Piping from Lagoon to Splitter	LS	TBD	\$ -	\$ -
Piping from SAGR to discharge	LS	TBD	\$ -	\$ -
<b>TOTAL</b>				<b>\$ 599,728.00</b>

\*Construction Unit Prices based on typical installed values. Pricing to be updated to reflect local construction costs

Any questions or comments can be directed to:

Nelson Environmental Inc.  
 5 Burks Way  
 Winnipeg, Manitoba, Canada  
 R2J 3R8  
 Tel: 204-949-7500  
 Fax: 204-237-0660



PLOT SIZE: 610mm x 914mm (24" x 36")

REDUCED SIZE PLOT - DO NOT SCALE

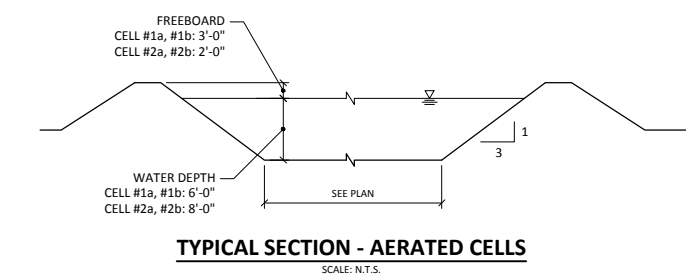
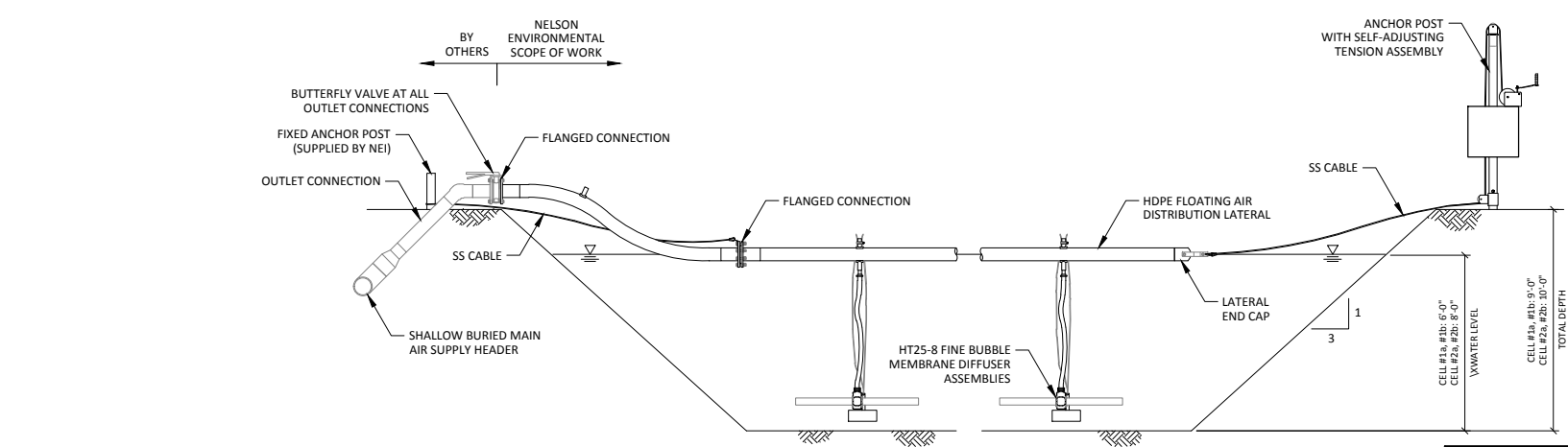
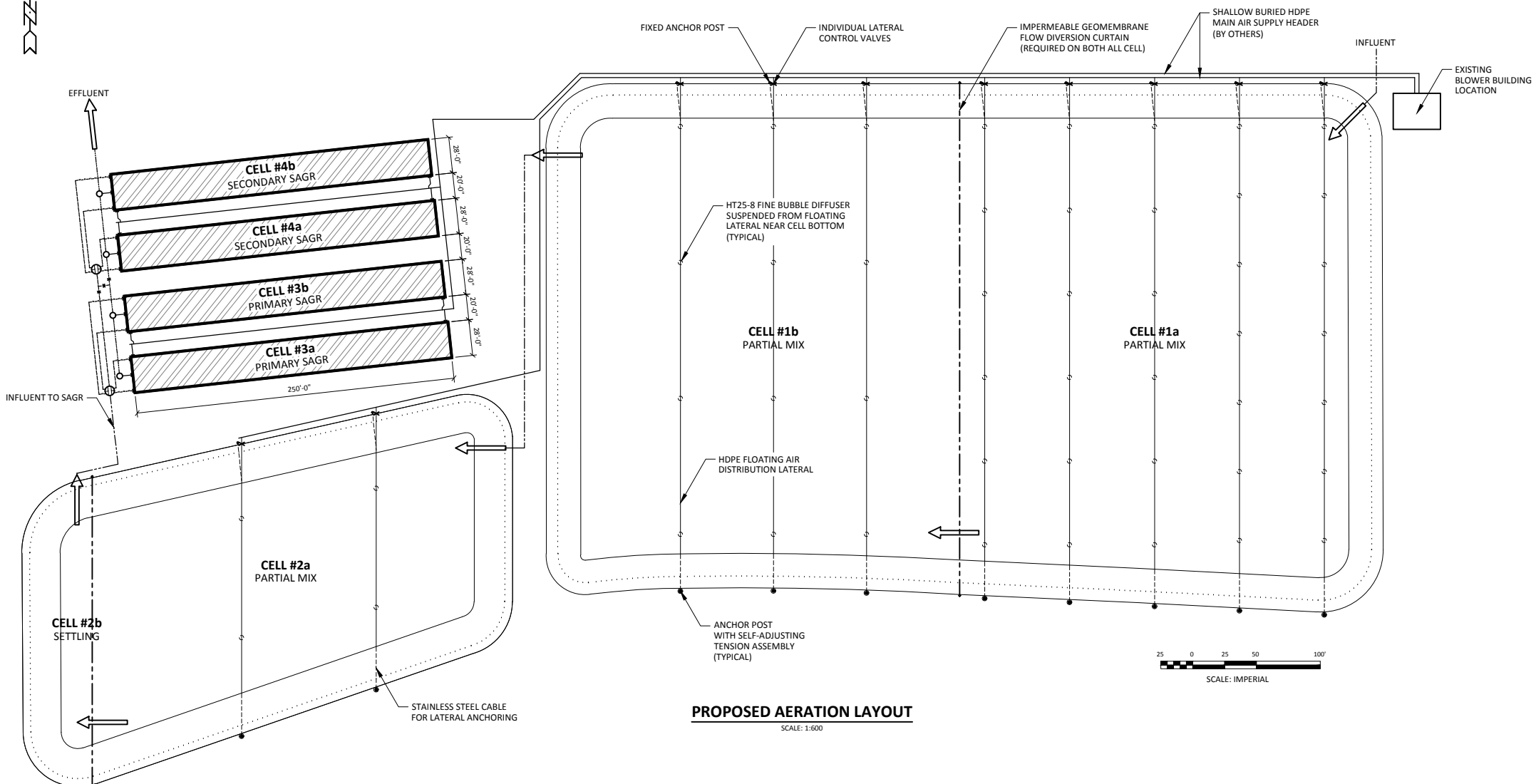
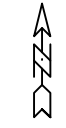

		<b>NELSON ENVIRONMENTAL INC.</b> 5 BURKS WAY WINNIPEG, MANITOBA CANADA R2J 3R8 Ph: (204) 949-7500 Fax: (204) 237-0660 www.nelsonenvironmental.com		PROJECT: <b>LONE TREE, IA</b> PROPOSED WASTEWATER TREATMENT SYSTEM TITLE: <b>PROPOSED OPTAER SYSTEM</b> PROPOSED AERATION LAYOUT, TYPICAL SECTION, LOCATION PLAN	
		DRAWN BY: AM DATE: 2016/07/27	APPROVED BY: MK FILE #: CD2872.01	SCALE: AS NOTED	DRAWING NO.: <b>NE01</b>

PLOT SIZE: 610mm x 914mm (24" x 36")

REDUCED SIZE PLOT - DO NOT SCALE

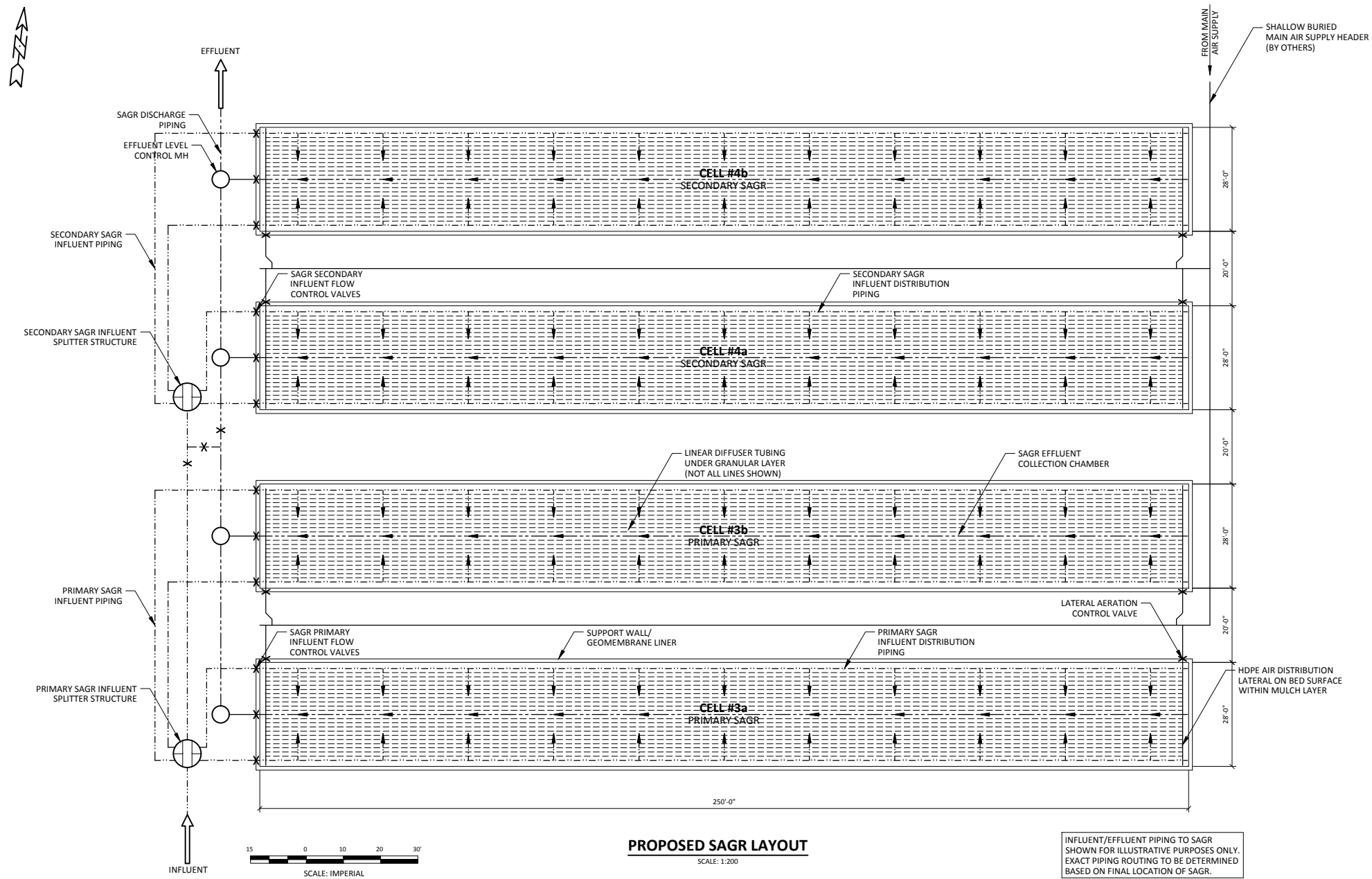

**NOTE FOR GRAVITY FEED SYSTEMS:**  
SAGR WATER LEVEL TO BE MINIMUM 300mm (12") LOWER THAN WATER LEVEL OF FINAL CELL.

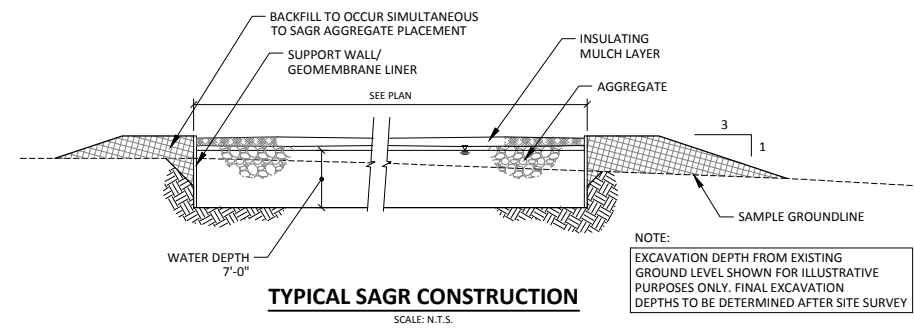
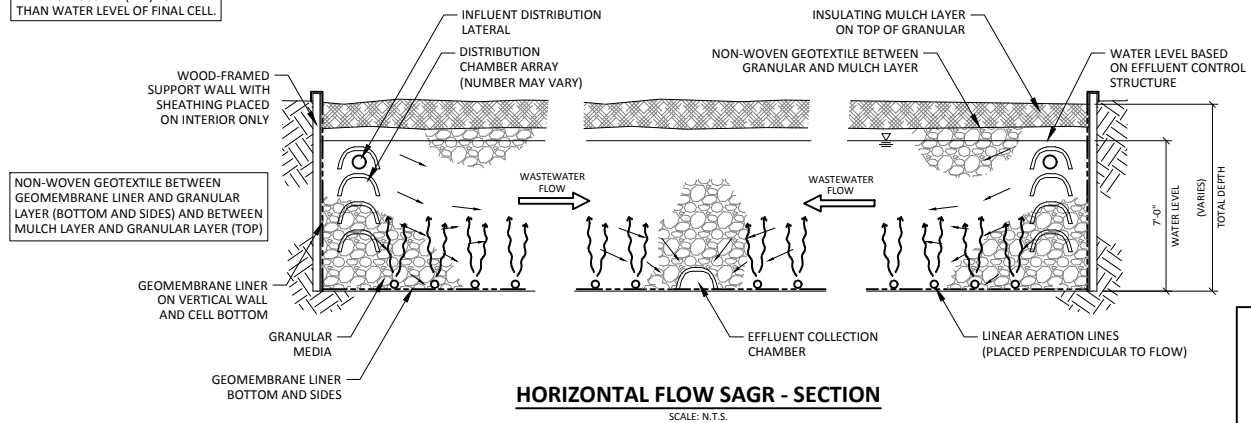

**NELSON ENVIRONMENTAL INC.**  
5 BURKS WAY  
WINNIPEG, MANITOBA  
CANADA R2J 3R8

Ph: (204) 949-7500  
Fax: (204) 237-0660  
www.nelsonenvironmental.com

PROJECT:		LONE TREE, IA	
TITLE:		PROPOSED WASTEWATER TREATMENT SYSTEM	
DRAWN BY:		PROPOSED OPTAER SAGR SYSTEM	
DATE:		PROPOSED SAGR LAYOUT, TYPICAL SECTION	
AM	MK	AS NOTED	FILE #
2016/07/27		CD2872.01	
DRAWING NO. <b>NE02</b>			SHT. 2 of 2
			REV. 0

# LEMTEC™ BIOLOGICAL TREATMENT PROCESS



PROPOSAL FOR: LONE TREE, IA

PREPARED FOR: Meredith Pearl  
Veenstra and Kimm  
Coralville, Iowa

PREPARED BY: JIM MARTIN  
PRESIDENT  
LET

Proposal Number: 1504  
Revision Number: 0  
August 1, 2016

## INTRODUCTION

Thank you for including the LemTec™ Biological Treatment Process (LBTP) in the planning of the treatment facility for the City of Lone Tree, IA. Based on the information provided, we have developed a preliminary design and budget estimate for this project. The objective of our proposed system is to provide the best possible biological treatment solution capable of meeting or exceeding your requirements in the most efficient and cost effective way possible.

This proposal has been prepared for Ms. Meredith Pearl, who is currently evaluating treatment alternatives for the City, and is interested in products/technologies that can provide improvements to the existing facility, in order to accommodate projected flows as well as meet BOD, TSS and ammonia limits.

Lemna Environmental Technologies' proposed process design is based upon the following design parameters and site data.

## DESIGN PARAMETERS

	Influent Summer	Influent Winter		Effluent Summer	Effluent Winter	
Flow Per Train	0.1849	0.1849	MGD			
CBOD <sub>5</sub>	52	124	mg/L	25	25	mg/L
TSS	69	140	mg/L	80	80	mg/L
Ammonia	11.4	11.4	mg/L	1.0	2.7	mg/L

The proposed LBTP design described below will achieve the basic requirements and provide a number of advantages to the end user which are unmatched by alternative technologies. The patented LBTP is an effective, reliable, and affordable aerated lagoon based biological treatment process which utilizes a series of aerobic treatment cells followed by a settling zone and a polishing reactor. The LemTec™ process is capable of achieving year-round effluent limits of 20 mg/l BOD, 20 mg/l TSS and 1.5 mg/l NH<sub>3</sub>-N at a fraction of the cost of other traditional wastewater treatment systems. With a reduced footprint, a process that is extremely reliable, and simple to operate, the LBTP is the highest performance lagoon-based package in the world and offers numerous advantages over other systems, including lower capital and operating costs, expandability and low maintenance.

## DESIGN OVERVIEW

The proposed design for Lone Tree utilizes two of the existing lagoons run in parallel to handle a total design flow of .3698 MGD. The depth of the lagoons will be 12' for the purposes of this design. Following the treatment lagoons, a Lemna Polishing Reactor will provide additional BOD removal and ammonia treatment.

For this design, each lagoon will be divided into three cells using Lemna's custom designed LemTec™ Reverse Miter Hydraulic, which will be installed to minimize short-circuiting between each cell. The first cell in each lagoon will be a complete mix cell utilizing high rate diffusers.

The complete mix zone of the LBTP process is an aerated, aggressively mixed cell that establishes an environment suitable for the rapid removal of BOD<sub>5</sub> by heterotrophic bacteria. The reduction of BOD<sub>5</sub> is calculated using state-of-the-art "mechanistic" models that relate to the growth of bacteria and removal of BOD<sub>5</sub> in relation to detention time and wastewater temperature. Similar models are currently used for the design of activated sludge plants.

In addition to BOD<sub>5</sub> removal, ammonia is also removed by heterotrophic bacteria present in the complete mix cell. Ammonia is utilized by the bacteria to support its nitrogen requirement for growth. Also, nitrifier growth will occur in the complete mix cell resulting in additional (and significant) ammonia reduction.

Following the complete mix cell, water will flow into partial mix cells utilizing low-rate diffusers. Partial mix cells require lower levels of aeration and mixing in order to effectively achieve BOD<sub>5</sub> removal. Using low rate diffusers, air will be introduced to maintain optimal degradation of BOD<sub>5</sub>. Mixing will also economically occur in order to achieve effective biological reaction rates and to maintain partial suspension of solids.

The last cell in both lagoons will be a settling cell with a detention time of 2.9 days. Low rate diffusers will be installed to provide additional aeration. All the cells in the proposed design will be covered by Lemna's LemTec™ Modular Insulated Cover rated at R10. The LemTec™ Cover prevents algae growth by eliminating sunlight below the cover and improves clarification in two ways: 1) it prevents wind action on the water surface thereby establishing a quiescent zone for solids to settle, and 2) the insulation minimizes seasonal and diurnal temperature fluctuations, thereby reducing stirring by thermal currents. The LemTec™ Cover improves TSS removal, provides algae prevention and encourages nitrification by regulating temperatures within the ponds.

Following the ponds, the LemTec™ Polishing Reactor will provide additional BOD and ammonia treatment. The LemTec™ Polishing Reactor (LPR) consists of submerged, attached-growth media modules used for maintaining an adequate population of bacteria. The LPR enhances the growth of nitrification bacteria to encourage conversion of ammonia to nitrates in an aerobic environment. Aeration is provided by



## DESIGN LAYOUT/DRAWINGS

Layout drawings are attached.

## LET PROJECT SUPPLY SCOPE

Engineering/Technical Services  
Lemna System Design Recommendations  
Lemna System Equipment Details  
Lemna System Plans and Specifications  
Lemna Design Calculations  
Regulatory Technical Support

Equipment Supply  
LemTec™ Insulated Cover  
LemTec™ Aeration System  
LemTec™ Polishing Reactor

Installation/Start-Up/Training  
Equipment Installation Supervision (Lemna Equip.)  
Process Start-Up/Training (Lemna Process)  
Ongoing Technical Support

**By others:** Civil Design, Electrical Design, Mechanical Design, Other Design Services (if required). Pond De-Sludging, Site Work/Improvements, Concrete Structures, Yard Piping (out of basin), Electrical Service to Site, Interconnect Wiring (Equipment to Equipment/ Remote Disconnect/MCCs/Control Panels).

## LET PROJECT PRICING

Equipment/Services	\$ -----
Equipment Freight (estimate)	\$ -----
<b>Total Proposed Price</b>	<b>\$ -----</b>

Proposed pricing is based on available information and is valid for 60 days. Prices are in US funds and do not include any applicable taxes. All sales are subject to LET's standard terms and conditions. Proposed price subject to change based on changes in final design and final scope at time of bid or based on size changes at time of final survey. Typical equipment lead time is 6-12 weeks after approval of final submittals. Equipment lead time is subject to change based on size of project, complexity of design, customer requirements and shop-loading at time of order.

## **LIMITED WARRANTY**

All LET supplied components are warranted against manufacturer's defects for a period of twelve months. This warranty does not cover wear or damage caused by improper installation, operation or maintenance. In the event of a manufacturer's defect, Lemna will repair or replace the damaged component. A process warranty based on the design parameters included as part of this proposal. This process warranty is contingent upon the full supply by LET of all equipment detailed in this proposal.



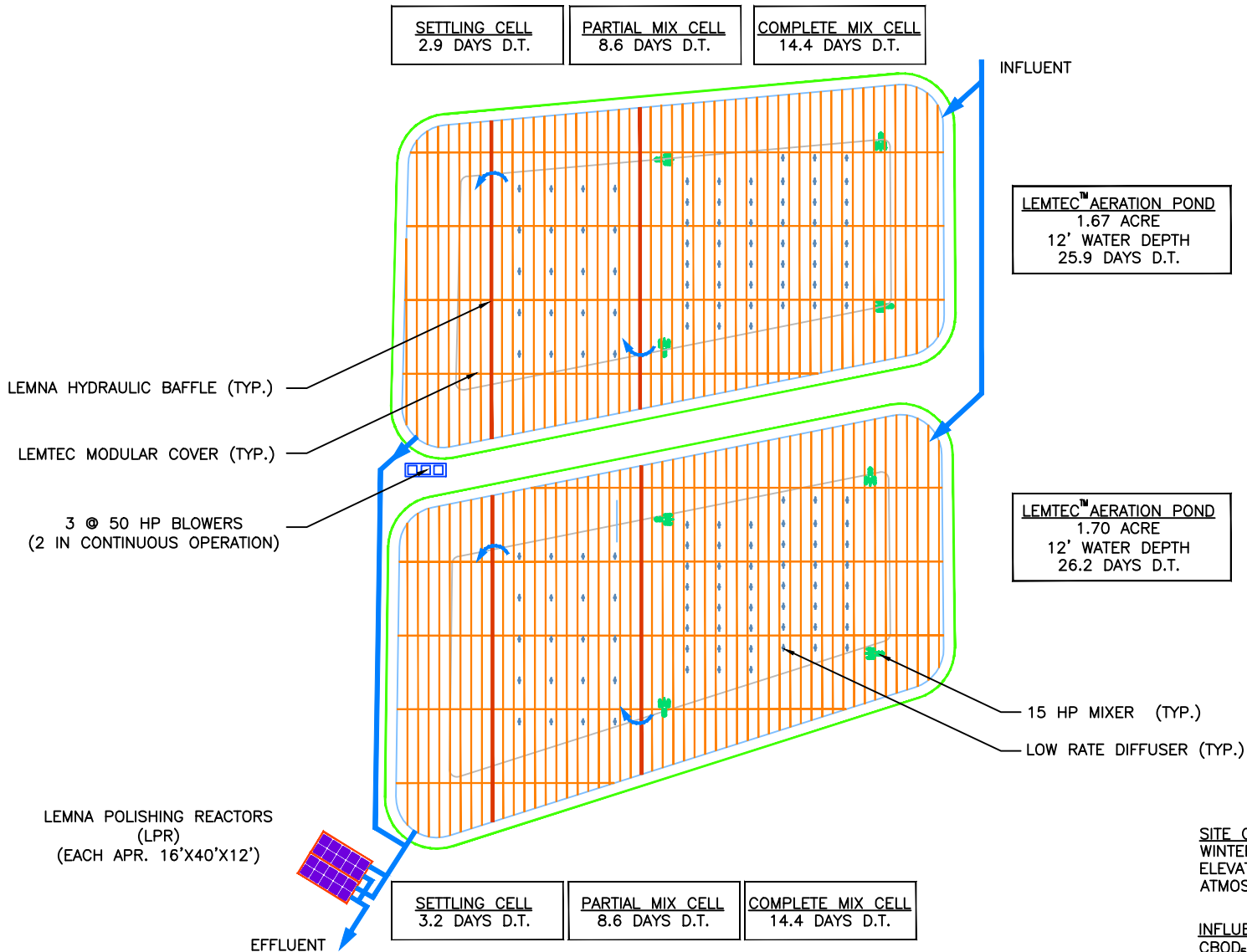

**DESIGN FLOW: 0.3698 MGD**

NOTE: 1) DESIGN BASED ON MINIMUM INFLUENT TEMPERATURE OF 10°C  
 2) TWO TRAIN DESIGN, FLOW RATE PER TRAIN 0.1849 MGD

SITE CHARACTERISTICS:  
 WINTER AIR TEMPERATURE: -5.0 °C  
 ELEVATION: 725 ft AMSL  
 ATMOSPHERIC PRESSURE: 14.3 psia

INFLUENT CHARACTERISTICS:  
 CBOD<sub>5</sub>=124 mg/l  
 TSS=140 mg/l  
 NH<sub>3</sub>=11.4 mg/l

EFFLUENT LIMITS:  
 CBOD<sub>5</sub>=25 mg/l  
 TSS=80 mg/l  
 NH<sub>3</sub>=1.0 mg/l (summer)  
 NH<sub>3</sub>=2.7 mg/l (winter)

THIS DESIGN IS PROPRIETARY TO LEMNA ENVIRONMENTAL TECHNOLOGIES, INC. AND IS SOLELY INTENDED FOR APPLICATION AT LONE TREE, IA  
 BY LEMNA ENVIRONMENTAL TECHNOLOGIES, INC. THIS DESIGN CANNOT BE USED BY A THIRD PARTY NOR REPRODUCED, IN FULL, OR IN PART, WITHOUT THE WRITTEN AUTHORIZATION OF LEMNA TECHNOLOGIES, INC.

DRAWN BY:	DAP
APPROVED BY:	JAM
SCALE:	NOT TO SCALE
DATE:	JULY 2016
SHEET NO.:	1 OF 1

## LEMTEC™ BIOLOGICAL TREATMENT PROCESS LONE TREE, IA

# The IDEAL<sup>®</sup> Solution Budgetary Design

**Intermittently Decanted Extended Aeration Lagoon  
(IDEAL) for Advanced Wastewater Treatment for  
Lonetree, IA**

**July 21, 2016**

Prepared for:

**Cory Sonner**  
Vessco



All information herein is confidential and to be considered property of EDI

Environmental Dynamics International  
5601 Paris Road  
Columbia, MO  
65202

(PH) 573.474.9456  
(FX) 573.474.6988  
[www.EnvironmentalDynamics.com](http://www.EnvironmentalDynamics.com)

**Lagoon**  
**Solutions**



## **Key Contacts**

### **EDI Representative**

**Cory Sonner**  
Vessco, Inc.  
Office: (515) 233-8599  
Cell: (515) 509-0470  
Email: csonner@vessco.com

### **Environmental Dynamics International**

**Tim Canter**  
Process Specialist  
Phone: (573) 474-9456 x 263  
Fax: (573) 474-6988  
Email: tim.canter@wastewater.com

**Patrick Ely**  
Territory Manager  
Phone: (573) 474-9456 x 212  
Email: marc.salmi@wastewater.com

**C.E. Tharp, P.E.**  
Chairman  
Phone: (575) 474-9456 x 210  
Fax: (573) 474-6988  
Email: charles.tharp@wastewater.com

# Table of Contents

	<b>Page</b>
<b>I. EDI Process Details and Support Options</b>	<b>1</b>
A. IDEAL Bioreactor Description	
B. Optional Process Components	
C. Optional EDI Installation, Warranty, and Service Programs	
<b>II. Specific Project Discussion</b>	<b>5</b>
A. Proposed Process	
B. Existing Infrastructure and Construction Narrative	
<b>III. Preliminary System Design</b>	<b>8</b>
A. Influent Wastewater Flow	
B. Influent Wastewater Quality	
C. Site Conditions	
D. Permit Effluent Requirement (Monthly)	
E. Preliminary IDEAL Sizing	
<b>IV. Budget</b>	<b>11</b>
A. Hardware Checklist	
B. Budgetary Cost Estimate	

## **I. EDI Process Details and Support Options**

### **A. IDEAL Bioreactor Description**

The Intermittently Decanted Extended Aeration Lagoon Solution incorporates an EDI floating or submerged lateral aeration system with premium fine bubble panel diffusers, two zones of BioReef™ BioCurtain™, decanters, blowers, and process controls.

The reliable components of the IDEAL system provide easy, cost-effective operation while providing high levels of BOD, TSS, and ammonia conversion with total nitrogen (TN) removal. The process is specifically engineered to minimize sludge management. Extremely high flow events are handled routinely with minimum biomass loss. The IDEAL process provides substantial total nitrogen reduction as part of the basic package, resulting in reduced air requirements and low energy cost. IDEAL is a basic process that can be easily expanded to accommodate strict total nitrogen or phosphorous limits.

The ability of the IDEAL Bioreactor to provide front-of-plant treatment provides several benefits over other lagoon-based technologies. By converting ammonia at the front of the plant the system can also utilize the influent carbon for denitrification, with oxygen and alkalinity recovery. Simple sludge management is incorporated as the IDEAL Bioreactor retains and maximizes biomass in the first cell for optimal treatment capability by using the entire surface of the bioreactor for clarification/solids separation. A programmed decant of the treated effluent provides superior quality discharge.

A unique advantage of the IDEAL process is the ability to treat high surge flows through the system without having significant impact on biomass concentration and without impairment post-surge treatment capability. The IDEAL's unique combination of suspended growth activated sludge plus attached growth biomass minimizes washout and avoids system overload. The entire IDEAL basin surface is used for solids separation so solids setting happens more effectively than in a smaller, conventional clarifier. Also, since the solids stay in the IDEAL Bioreactor, there is no need for complicated return sludge pumping and solids management.

#### ***IDEAL Benefits***

##### ***Front-of-the-Plant Ammonia Conversion***

The IDEAL Process removes BOD and converts ammonia to nitrate up front where warm, carbon-rich influent wastewater is available to increase biological activity and drive denitrification. Other processes look to the back of the plant for ammonia removal where BOD concentration is lowest and where temperature loss can be significant resulting in limited process performance or control.

##### ***Nitrate and Total Nitrogen Removal***

Converting ammonia to nitrate is the first step in total nitrogen removal. Denitrification, or removing nitrate nitrogen is the second step necessary for total nitrogen removal. The IDEAL Process provides the benefit of concurrent nitrification and denitrification as a natural function of the process and is easily expanded for maximum total nitrogen and phosphorous control. Total nitrogen, nitrate and total phosphorous restrictions are on the horizon in almost all States. The

IDEAL system with add-on modules expands performance by using standard IDEAL infrastructure with economic expansion modules or options.

#### *Total Phosphorous Removal*

Basic TP Removals within the IDEAL Bioreactor are routine at about 2.5% of BOD removed. For example, if 200 mg-BOD/L is reduced to 10 mg-BOD/L then the resulting biological TP reduction via assimilation will be approximately 4.8 mg/L. Coagulant addition and/or tertiary filtration can be easily incorporated to drive effluent TP down to the lowest levels possible.

#### *Energy and Chemical Savings*

Denitrification occurs naturally in the IDEAL Bioreactor when microbes use nitrate as a source of oxygen to remove BOD. This step in total nitrogen removal occurs due to the front-of-the-plant treatment approach. Denitrification lowers oxygen requirements and reduces operational energy cost. The alkalinity recovered during denitrification can decrease or eliminate the need for chemical addition that may be required to allow complete nitrification.

#### *Worry-Free Operation During and After Peak-Plus Flow Events*

The IDEAL Process has shown an excellent ability to maintain performance during and after heavy wastewater surges that exceed design flow rates. IDEAL also easily adjusts to varying degrees of organic loading as the combination suspended growth and attached growth process in the IDEAL Bioreactor buffers these loadings and provides excellent process stability.

#### *Long-Term Compliance Planning*

Upgrades for advanced system control with additional or higher degrees of pollutant removal are simple; only requiring treatment module additions. No modification to the core treatment process is necessary for expansion of performance when adding polishing filters, sludge digestion modules, coagulant for simple phosphorus removal, oxygen control for enhanced total nitrogen removal, etc.

## **B. Optional Process Components**

The IDEAL Bioreactor is the System's primary treatment mechanism. Several IDEAL total system configurations are available to produce optimum treatment levels, and lowest operation cost for each treatment objective.

### **1. Partial Mix and Polishing Cells Following IDEAL**

This is the simplest process configuration that allows automatic sludge management by allowing all excess solids to discharge from IDEAL to the partial mix cell and quiescent polishing cell. The decanter functions to maintain biomass for treatment but allows excess biomass to escape to the partial mix cell. Best in warm climates where biomass that accumulates in partial

mix cell digests completely and eliminates the potential for nutrient rebound in spring. Algae management in partial mix and quiescent cell must be considered.

## **2. Sludge Management Lagoon Independent of Process Flow Stream**

This option wastes excess sludge directly from the IDEAL Bioreactor to a sludge digester or to sludge lagoon for stabilization and sludge management. Separate management of excess sludge may allow direct discharge of high effluent quality from the IDEAL Bioreactor. No algae issues for most facilities.

## **3. Filtration Following IDEAL Bioreactor**

The high quality effluent from IDEAL can be enhanced and polished to achieve suspended solids < 5 mg/L and provide additional BOD removals following IDEAL reactor discharge. This option allows direct filtration of IDEAL reactor discharge with or without flow equalization ahead of filters. To utilize this option, sludge management (item #2 above) must be employed to minimize solids loading to filters. Filter backwash is about 1% forward flow and solids captured with backwash flow return to the sludge lagoon. EDI's premium cloth disc filter is utilized for this option. Option may reduce energy and/or second lagoon construction cost as partial mix aeration is not required.

## **4. Phosphorous Removal Module**

The IDEAL Bioreactor can be operated to maximize biological phosphorus removal by the addition of MLSS recirculation to the inlet zone before BioReef Zone #1. More advanced phosphorous removal can be achieved with a combination of coagulant addition to the IDEAL Bioreactor and/or the addition of the disc filter. Flocculation ahead of the cloth filters from option #3 can reach total phosphorus levels as low as 0.02 mg/L.

## **5. Excess Flow Management**

When upgrading existing lagoons, an existing lagoon or lagoons may be re-purposed to provide flow equalization ahead of the IDEAL Bioreactor when hydraulic loads exceed typical design values of 3-5 times average flow. Equalization basin can be aerated or non-aerated as preferred. Features incorporated into the IDEAL Bioreactor for excess flow management include water level control and flood cycle programming.

## **6. Other Options**

- Enhanced selector zones before IDEAL Bioreactor.
- Insulated covers for nitrification/denitrification in cold climates.
- Algae Control - Shade of polishing quiescent lagoon with UV protection.

## **C. Optional EDI Installation, Warranty, and Service Programs**

### **Extended Warranty and Maintenance Package**

EDI Aeration Works™ division was created to give operators of aeration systems a source for fast, reliable installation and maintenance. The EDI Aeration Works group is made up of experienced installers and field service professionals. Aeration Works personnel are experts at the installation and maintenance of aeration systems with process and operational optimization objectives.

Aeration Works expert installers are faster and more thorough than someone new to installing aeration systems. Aeration Works know what tools are needed, how to perform installations quickly, and how to ensure it is done exactly to manufacturer's specifications. When doing maintenance, the Aeration Works group has the experience to evaluate the degree of work needed and work to properly refurbish a system for maximum long term performance. When construction crews or contractors have already been selected, Aeration Works can also provide supervision to assure the work is done to manufacturer's specification.

### **Preventative Maintenance Program**

This plan allows facility operators to outsource the regularly scheduled maintenance of their aeration systems to EDI Aeration Works group. EDI contracts the maintenance and will clean diffuser membranes and make required system repairs. When this program is chosen as part of a new IDEAL Process sale, the mechanical warranty of the aeration system is extended as long as a service agreement is in place. Aeration Works can inspect any existing aeration or treatment system and a preventative maintenance program can be offered. The benefits of this plan include:

- Prevention of unscheduled outages
- Easy budgeting with a single annual expense to cover all parts and labor
- Increased energy efficiency and savings
- Decreased operating costs

### **Infinity Program™**

This program offers the same mechanical warranty and services as the Preventative Maintenance Program but goes one step further by guaranteeing the performance of the aeration system. Under this program, EDI maintains the physical condition of the membranes through preventative maintenance procedures and will periodically measure the performance of the membrane. Aeration Works will repair, replace, or adjust the equipment to ensure the aeration system operates within a pre-determined performance envelope.

- All Preventative Maintenance Program benefits are valid for this program
- New membranes will be provided on a nominal six-year cycle
- Maximize energy efficiency and operation savings



## II. Specific Project Discussion

### A. Proposed Process

The EDI IDEAL Bioreactor has a great deal of flexibility and can be incorporated into multiple process configurations. The IDEAL can be designed to meet maximum levels of biological treatment and enhanced levels of nutrient removal with the use of side-stream sludge management, process oxygen control, and/or tertiary filtration. Likewise, the basic IDEAL process can take advantage of lagoon simplicity and provide an excellent quality of water with minimal operator oversight and system control requirements.

The IDEAL is able to produce a very high quality of water without the need for post-treatment polishing. Therefore, direct discharge from the IDEAL Bioreactor reactor may be preferred for the simplicity and affordability of the basic system. If disinfection or a steady effluent flow is required then EDI recommends the use of a post-treatment equalization basin. Either of these selections requires the use of a side-stream sludge digestion and holding basin (Figure 1). Flow equalization is needed prior to disc filtration.

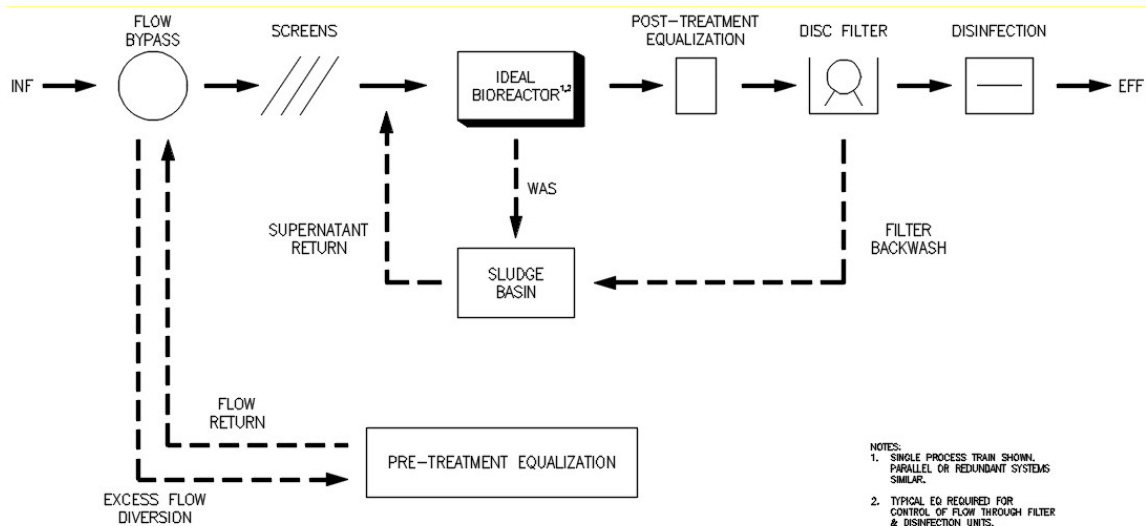

Figure 1. IDEAL Bioreactor with Side-Stream Sludge Wasting, Post-Treatment EQ, Optional Pre-Treatment Equalization, and Optional Disc Filtration

#### Pre-Treatment Flow Equalization

Applications with high levels of I&I can become problematic to many physical and biological wastewater treatment processes. However, for the IDEAL Solution, high peak influent flows are simply an opportunity to utilize existing lagoon infrastructure for pre-treatment equalization. The any flows above a given design peak can be redirected to existing basins for storage until dry weather flows in warm weather resume, presenting the opportunity to pump the flow back into the system for treatment.

#### Post-Treatment Flow Equalization and Optional Disc Filtration

The IDEAL Bioreactor is a constant inflow, batch outflow process, similar to many sequencing batch reactors. The result is a high level of treatment and four hours of water flow released over the course of an hour during normal operation (this may change depending on

site-by-site operational selections). A post-treatment equalization basin provides the system with a means to normalize water flow after treatment in the IDEAL and can reduce the size of disinfection equipment or other downstream process.

The post-treatment EQ basin can be constructed as a lined earthen basin or as a concrete tank. EDI provides general sizing recommendations for this basin. Once water from the IDEAL enters this basin it can either gravity-flow out of the basin, provided adequate hydraulic grade, or it can be pumped to downstream processes.

Disc filtration is recommended for maximum removal of TSS, BOD, and/or total phosphorus. The EDI Disc Filter is superior in its simplistic design and operation. Unlike many filters on the market today, the EDI Disc Filter uses removable filter sections that are backwashed by a moving arm. This results in highly economical installation and maintenance compared to those filters that rotate the entire filter system for the backwash function. Although it may not be needed today, EDI highly recommends planning for eventual installation of a filter to accommodate future phosphorous regulations.

#### Sludge Digestion Basin

For any high rate and efficient biological process excess bio-solids will be generated and must be managed. For extended aeration, conventional activated sludge or the EDI-IDEAL™ advanced wastewater treatment process, excess solids must generally be removed from the biological reactor, concentrated, digested, and then disposed. Traditional lagoon-based systems are designed to retain solids within the treatment basins. Complete Mix (CM) lagoons are followed by Partial Mix (PM) lagoons, which serve as the digester or sludge storage and management for the system.

A lagoon digester can be effective use of existing infrastructure. The lagoon digester can be aerobic, facultative, or anaerobic, depending on the goals of the owner and/or engineer. Note a concrete digester structure can be effective in stabilizing the sludge as well, with solids disposed to land application or other process.

The IDEAL Bioreactor is modeled using a controlled sludge age to provide adequate design of sludge wasting pumps and related components. Sludge wasted from the IDEAL is directed to the digester for stabilization and reduction. The digester should incorporate an overflow or small settling zone so that supernatant can flow back and mixed with influent to the IDEAL for reprocessing. The frequency of solids disposal depends on the size and nature of the digester.

## **B. Existing Infrastructure and Construction Narrative**

The IDEAL Bioreactor by EDI provides a great deal of flexibility during planning and construction, as well as during operation. The “front-of-the-plant” treatment philosophy is achieved by concentrating biomass, allowing the reactor to be relatively small compared to other options.

Figure 2 shows an example layout in the Lonetree, IA site. The northwest basin primarily functions as a quiescent zone, and can be taken offline while sacrificing minimal plant treatment capacity. If there is no available footprint outside of the existing basins for placing the IDEAL solution, then EDI recommends placing two parallel IDEAL Bioreactors within the existing

quiescent cell footprint. An additional portion of this cell can be used as post treatment equalization. The remainder of the cell can be used as pre-treatment equalization. EDI recommends the use of earthen berms for cell construction in order to minimize capital costs while creating hydraulic barriers between cells.

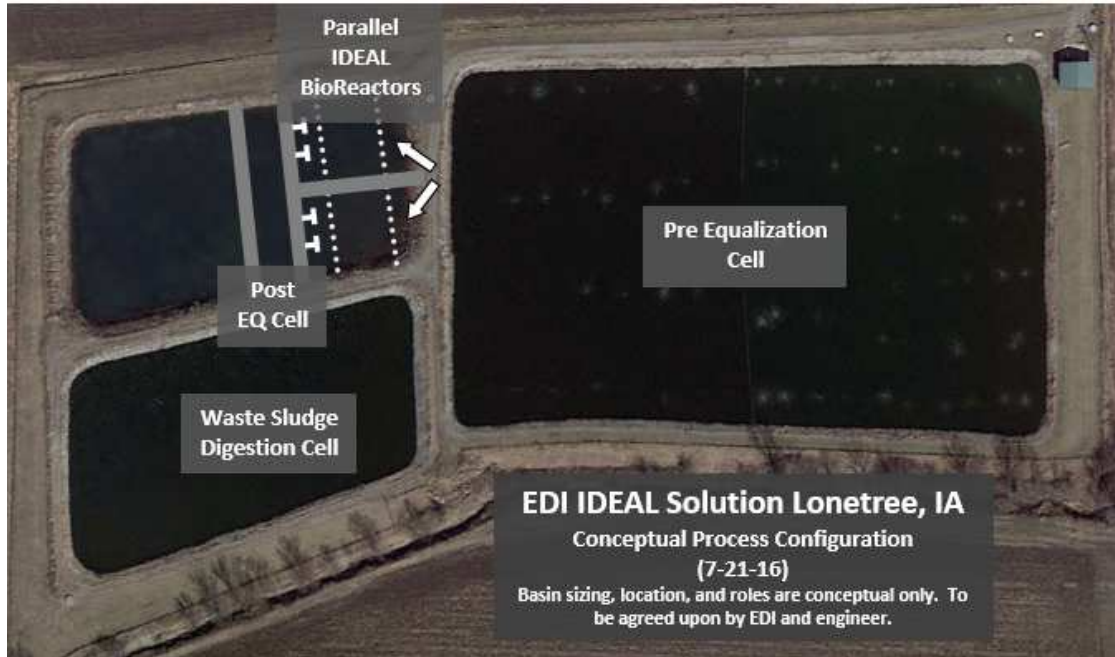

Figure 2. Example Layout to Show Potential Location and Proportions and Basins

Both IDEAL bioreactors will operate in parallel, receiving constant influent, split evenly between the two. Each basin will operate on opposing operation/aeration schedules, allowing for airflow to be redirected from one basin to the other every two hours, rather than turning blowers off and on.

Once the IDEAL reactors begin operation, then the existing aeration cell will no longer be used for treatment. Rather, it can be used to store flows in excess of the design Max Wet Weather flows, to be pumped into the IDEAL cells during dry weather flows. The other southwest basin can be used as a waste sludge storage pond and will be nominally aerated.

EDI's Aeration Works division specializes in lagoon retrofits. We invite you to engage them prior to construction planning for additional input including staging, planning, and budgeting.

### III. Preliminary System Design

#### A. Influent Wastewater Flow

Parameter	Value	Unit
Design Average Flow	0.176	MGD
Design Peak Flow	0.822	MGD

\* Estimated value

#### B. Influent Wastewater Quality (Design)

Parameter	Value	Unit
<b>BOD Concentration</b>	245	mg/L
<b>BOD Loading</b>	360	lb/d
<b>TSS Concentration</b>	321	mg/L
<b>TSS Loading</b>	472	lb/d
<b>Ammonia Concentration</b>	33	mg/L
<b>Ammonia Loading</b>	49	lb/d
<b>TKN Concentration</b>	53	mg/L
<b>TKN Loading</b>	78	lb/d
<b>Alkalinity Concentration</b>	150	mg/L
<b>Alkalinity Loading</b>	220	lb/d

\* Estimated value

#### C. Site Conditions

Parameter		Value	Unit
Reactor Temperature*:	Max	22	°C
	Min	8	°C
Ambient Temperature	Max	30	°C
	Min	-12	°C
Site Elevation (at berm)		675	ft

\* Estimated Value

#### D. Permit Effluent Requirement (Monthly)

Parameter		Design Value	Unit
<b>Average BOD<sub>5</sub></b>	Concentration	25	mg/L
	Load	88	lb/d
<b>Total Suspended Solids</b>	Concentration	80	mg/L
	Load	278	lb/d
<b>Ammonia-Nitrogen</b>	Oct. – March	Concentration	2.7
		Load	9.2
	April – Sept.	Concentration	1.0
		Load	3.4
<b>pH</b>	Max	8	
	Min	6	
<b>Dissolved Oxygen</b>	Min	N/A	mg/L

### E. Preliminary IDEAL Sizing

Parameter (per Basin)	Value	Unit
Number of Basins	2	
High Water Depth	8.0	ft
Side Slope	3.0:1	(Length:Depth)
Basin Length @ H.W.L.	138	ft
Basin Width @ H.W.L.	78	ft
Basin Length @ floor	90	ft
Basin Width @ floor	30	ft
Freeboard	2.0	ft
# of Decanters (per basin)	2	
# of BioReef Curtains (per basin)	2	
# of Laterals (per basin)	10	

Note: Design criteria provided for one basin. Multiple basins assumed to be identical and will run in parallel.

## IV. Budget

### A. Hardware Checklist

#### Two (2) IDEAL Bioreactors

	YES	Not Required	By Others
A. Screen and/or Grit Removal	<input type="checkbox"/>	<input type="checkbox"/>	<input checked="" type="checkbox"/>
B. Premium Positive Displacement Blower Package	<input checked="" type="checkbox"/>	<input type="checkbox"/>	<input type="checkbox"/>
C. IDEAL Aeration System, Complete	<input checked="" type="checkbox"/>	<input type="checkbox"/>	<input type="checkbox"/>
a. Floating Laterals and Supports			
b. Retrievable Assemblies and Diffusers			
c. Purge and Miscellaneous			
D. BioReef BioCurtain	<input checked="" type="checkbox"/>	<input type="checkbox"/>	<input type="checkbox"/>
a. Influent			
b. Effluent			
E. WAS Pumps	<input checked="" type="checkbox"/>	<input type="checkbox"/>	<input type="checkbox"/>
F. Decanters	<input checked="" type="checkbox"/>	<input type="checkbox"/>	<input type="checkbox"/>
G. Influent Manifold	<input checked="" type="checkbox"/>	<input type="checkbox"/>	<input type="checkbox"/>
H. Probes / Bioreactor			
a. Liquor Level & Storm Mode	<input checked="" type="checkbox"/>	<input type="checkbox"/>	<input type="checkbox"/>
I. Valves			
a. Decanter Valves and Actuators	<input checked="" type="checkbox"/>	<input type="checkbox"/>	<input type="checkbox"/>
J. Process Controls	<input checked="" type="checkbox"/>	<input type="checkbox"/>	<input type="checkbox"/>
a. Energy-Smart Blower Operation			
b. ArcArmor™ Tri-Panel System or Similar			
c. Soft Starters for Blowers			
K. Thermal Cover	<input checked="" type="checkbox"/>	<input type="checkbox"/>	<input type="checkbox"/>
L. Engineering Support for IDEAL	<input checked="" type="checkbox"/>	<input type="checkbox"/>	<input type="checkbox"/>
M. Training and Field Service	<input checked="" type="checkbox"/>	<input type="checkbox"/>	<input type="checkbox"/>
a. Documentation and IOM Manuals			
b. On Site Start Up Support			
c. On Site Operator Process and Maintenance Training			
d. Two-Year Onsite Support Package			
N. Mechanical and Process Warranties	<input checked="" type="checkbox"/>	<input type="checkbox"/>	<input type="checkbox"/>
O. Freight to Site	<input checked="" type="checkbox"/>	<input type="checkbox"/>	<input type="checkbox"/>
P. Optional Extended Maintenance Contract Available	<input checked="" type="checkbox"/>	<input type="checkbox"/>	<input type="checkbox"/>

\*Available with EDI Package once sizing determined.

**B. Budgetary Cost Estimates\***

**EDI Lagoon Solutions – IDEAL Bioreactor:**

**\$ \_\_\_\_\_ U.S.D.**

System as described in previous sections.

Includes Extended 2 year Field Service, operator support and training, plus supervision and coordination of monitoring.

**BioInsulate Cover to Protect Equipment and Enhance Biological Activity in Extreme Climates:**

**\$ \_\_\_\_\_ U.S.D.**

\*All prices to be reviewed upon confirmation of project scope and hardware specifications.

## **Environmental Dynamics International**

5601 Paris Road  
Columbia, MO 65202

(PH) 877-334-2478

573-474-9456

(FX) 573-474-6988

[www.environmentaldynamics.com](http://www.environmentaldynamics.com)

